

advanced FLOW engineering Magnum Force Stage-2 Cold Air Intake System

Instruction Manual P/N: 54-13060D / 54-13060R

Make: Chevrolet	Model: Silverado 1500	Year: 2014-2018	Engine: V8-5.3L
Make: Chevrolet	Model: Silverado 1500	Year: 2014-2018	Engine: V8-6.2L
Make: Chevrolet	Model: Silverado LD 1500	Year: 2019	Engine: V8-5.3L
Make: GMC	Model: Sierra 1500	Year: 2014-2018	Engine: V8-5.3L
Make: GMC	Model: Sierra 1500	Year: 2014-2018	Engine: V8-6.2L
Make: GMC	Model: Sierra Limited 1500	Year: 2019	Engine: V8-5.3L



- Please read the entire instruction manual before proceeding.
- Ensure all components listed are present.
- If you are missing any of the components, call customer support.
- Ensure you have all necessary tools before proceeding.
- Do not attempt to work on your vehicle when the engine is hot.
- Retain factory parts for future use.

Label	Qty.	Description	Part Number
A1	1	Air Filter (Pro 5R)	24-91120
A2	1	Air Filter (Pro DRY S)	21-91120
B	1	Tube	05-74104B1
C	1	Housing	05-5413060B2
D	1	Seal, Trim: 13/32" Double Bulb (38" Length)	05-01534
E	2	Clamp, 056 (3-1/16" - 4")	03-50009
F	1	Coupling, Silicone Bellow (5.3L only)	05-01389
G	2	Screw, Torx: M4 x .7 x 8mm	03-50491
H	1	Hose, Silicone Breather, Black (13" Length)	05-01396
I	1	Hose, Silicone Breather, Black (16" Length)	05-01396
J	1	Coupling, Silicone Bellow (6.2L only)	05-01508
K	1	Clamp, 060 (3-15/16" - 4-1/4")	03-50002
L	1	Seal, Trim: 3/4" Bulb (26" Length)	05-01507

Installation will require the following tools:

8mm nut driver, T15 & T20 Torx drivers, Phillips #3 screwdriver, small flat-head screwdriver.

Emissions Disclaimer: This product is not currently CARB exempt and is not available for purchase in California or for use on any vehicle registered with the California Department of Motor Vehicles.

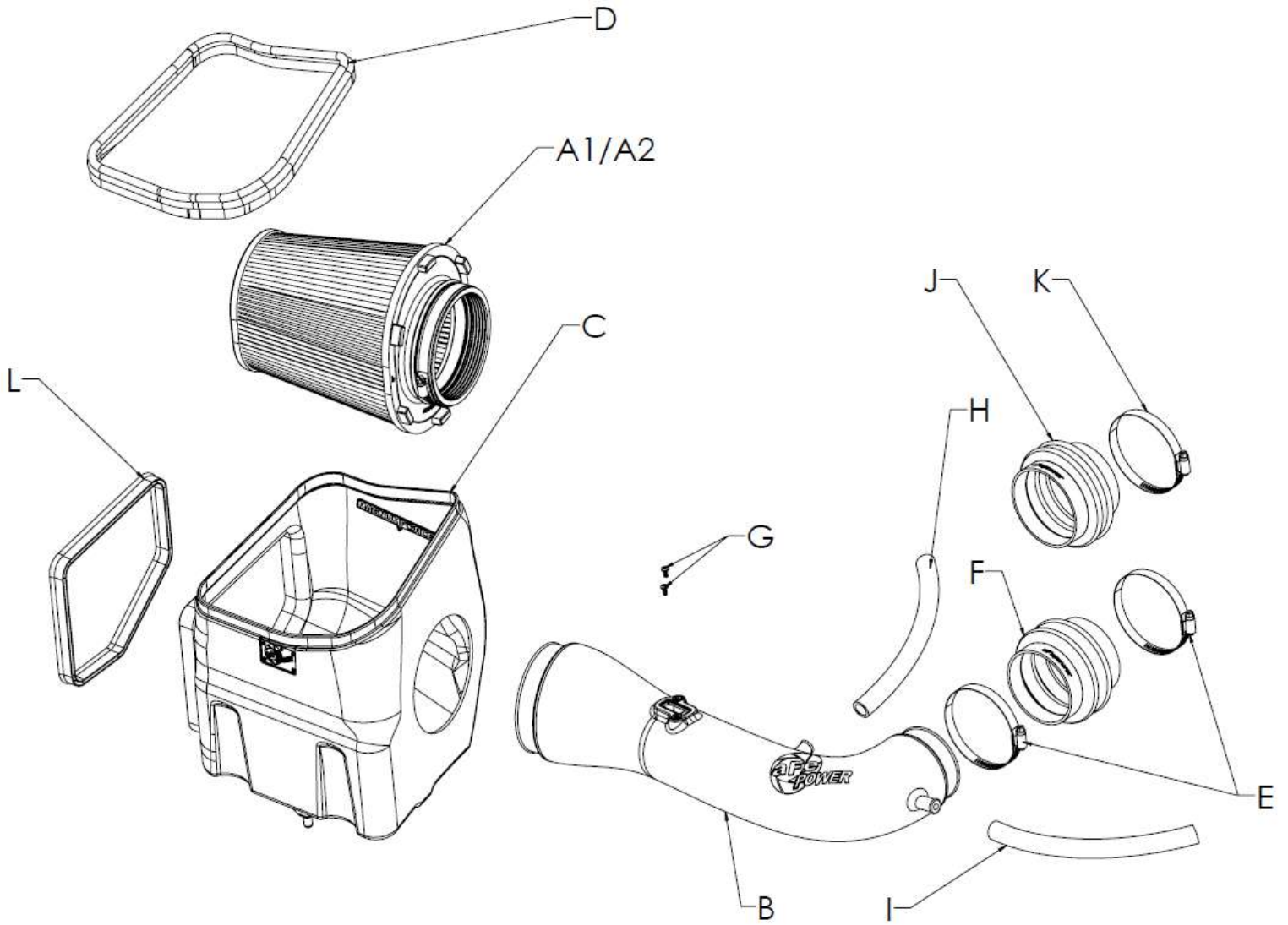

**Figure A****Refer to Figure A for Steps 1-2**

Step 1: Disconnect the MAF sensor (1).

Step 2: Using an 8mm nut driver, loosen the hose clamps at the housing (2) and the throttle body (3).

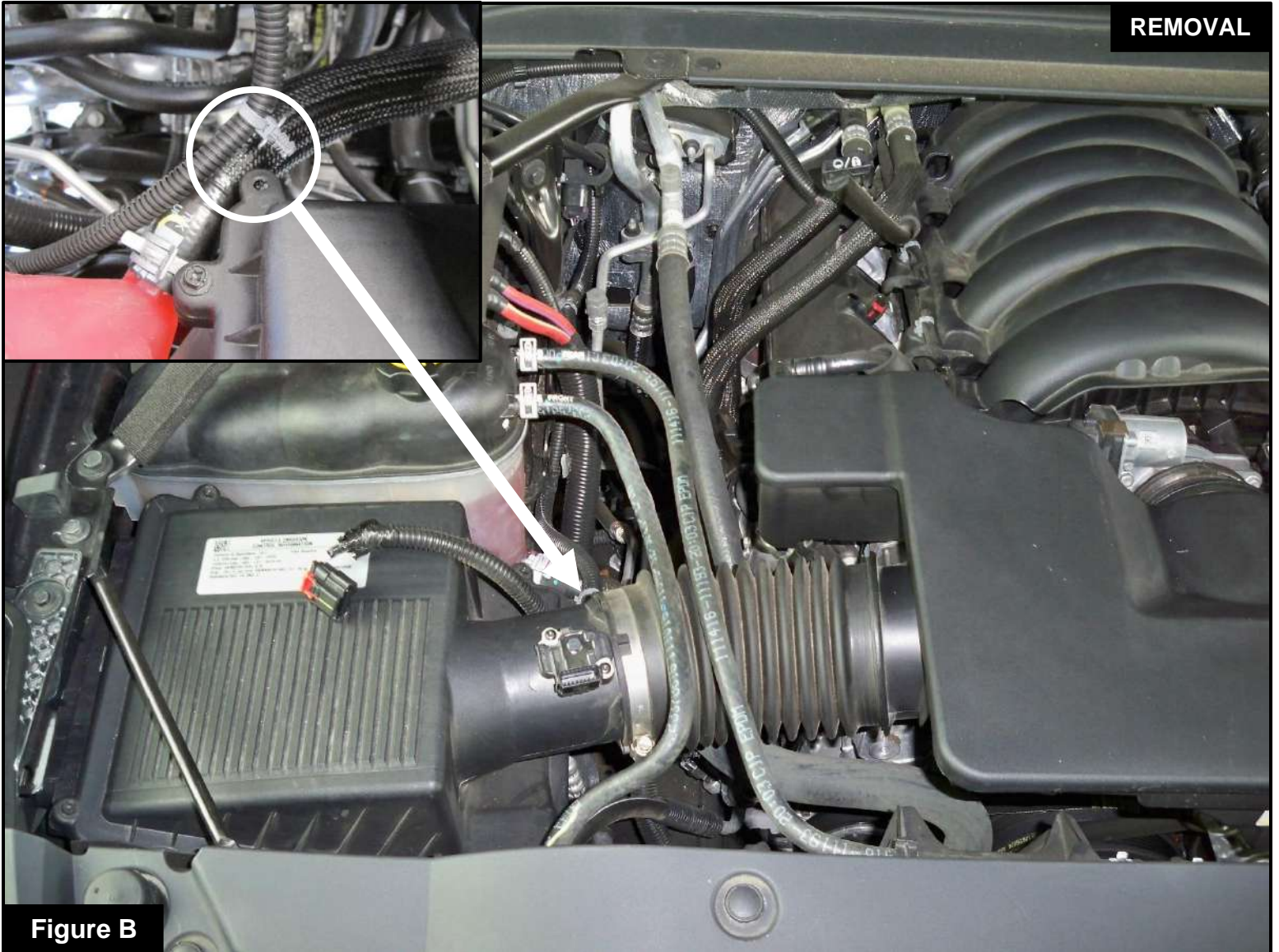
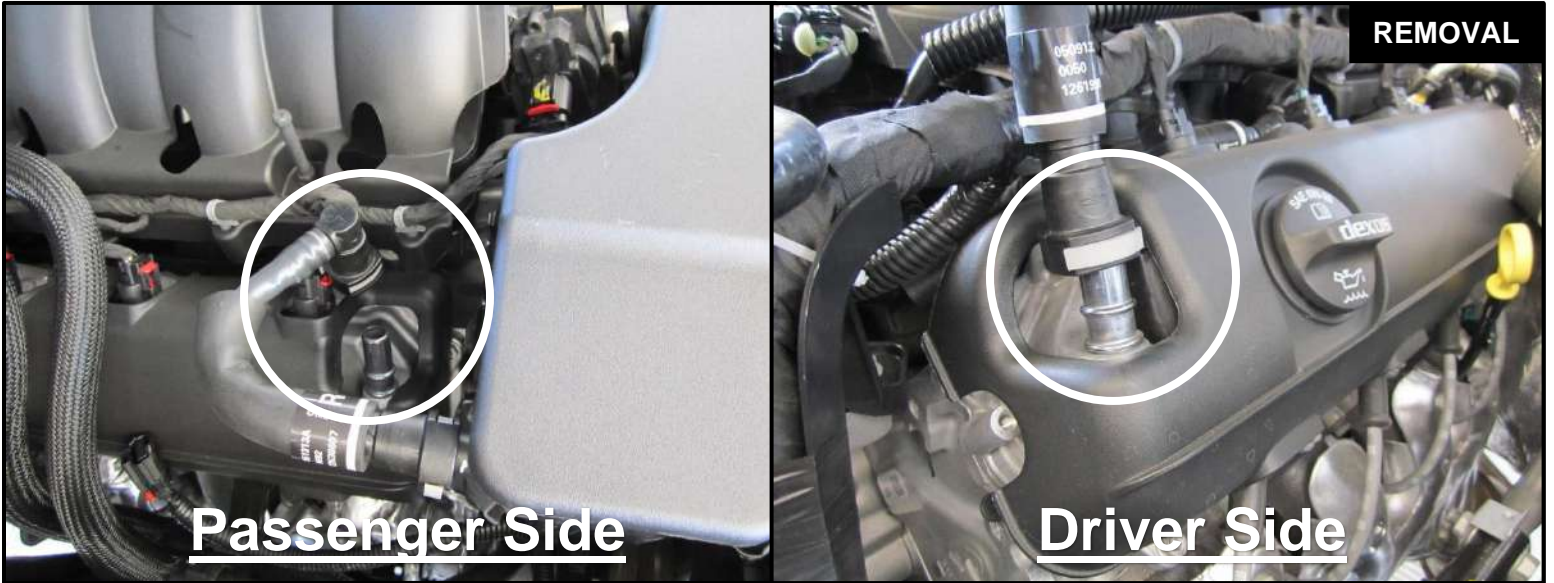

Figure B

Refer to Figure B for Step 3

Step 3: Disconnect the MAF sensor harness clip from the OE housing.



Refer to Figure C for Steps 4-5

Step 4: Disconnect the OE crankcase breathers from the valve covers (as shown) on both sides of the engine.

Step 5: Carefully remove the entire intake tube plenum with the crankcase breather plugs attached.

**Figure D****Refer to Figure D for Step 6**

Step 6: Remove the factory housing ④ out of the vehicle.

**Figure E****Refer to Figure E for Steps 7-8**

Step 7: Slide the aFe filter into the housing top first, as shown. Pull the filter flange through the round hole until it snaps into place and is full seated.

Step 8: Install the longer seal trim on top edge of the housing.



Figure F

Refer to Figure F for Steps 9-10

Step 9: Install the trim seal (5) on the side opening of the aFe housing.

Step 10: Remove the retaining plug (6) from the bottom of the factory housing and transfer it to the aFe housing.



Figure G

Refer to Figure G for Step 11

Step 11: Install the aFe housing assembly into the vehicle. Firmly push the housing into the factory mounting grommets.

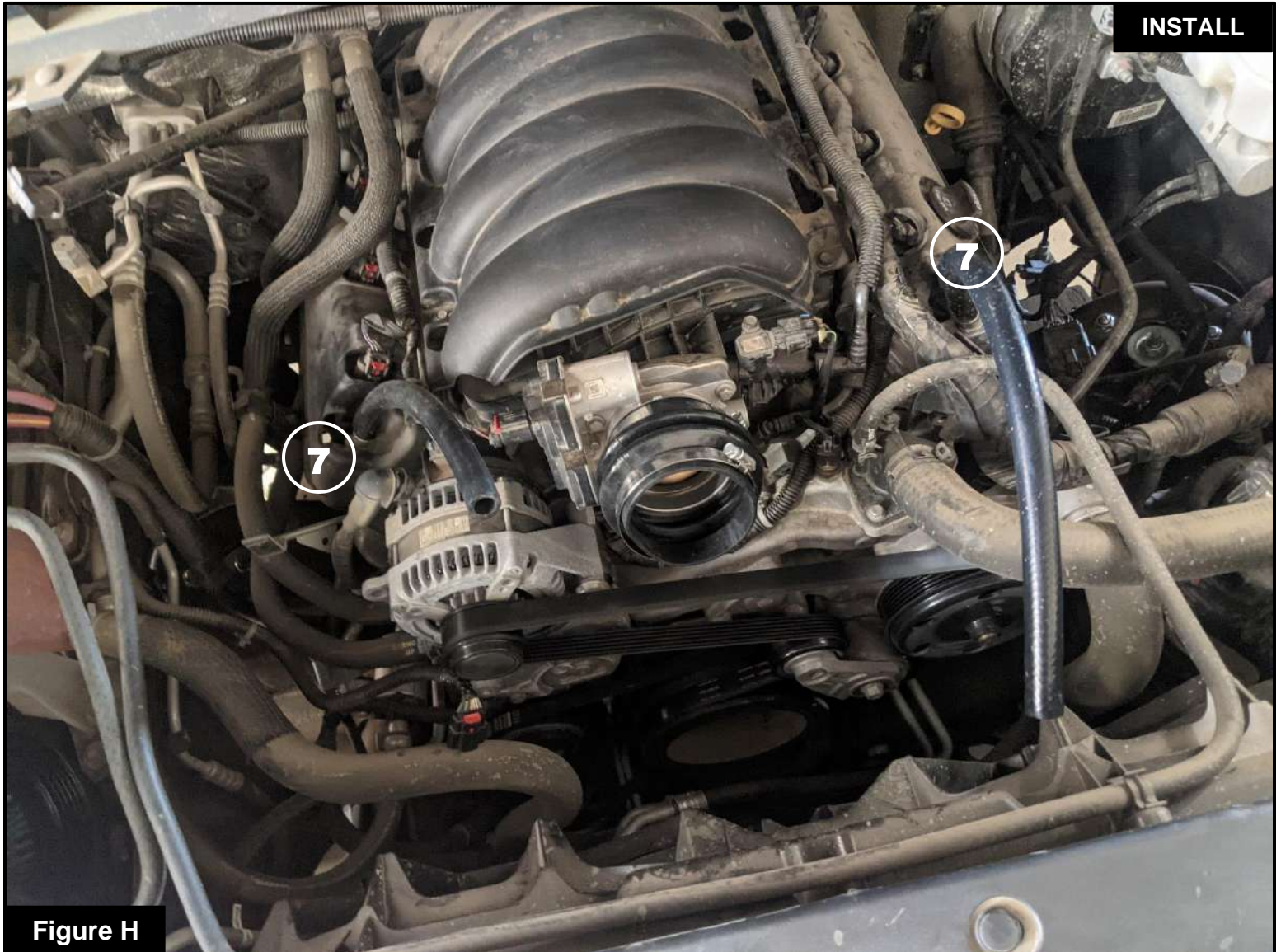

Figure H

Refer to Figure H for Steps 12-13

Step 12: For V8-6.2L, install the supplied reducer bellows coupling 05-01508 and the #60 clamp on the throttle body.

For V8-5.3L, install the supplied straight bellows coupling 05-01389 on the throttle body and the #56 clamp. Place a #56 clamp on the other end of the coupling. Do not tighten the clamps at this time.

Step 13: Install the two supplied crankcase breather hoses onto the valve cover on both sides of the engine. Make sure the hoses are secure all the way to the bead on the valve covers. ⑦

**Figure I****Refer to Figure I for Steps 14-15**

Step 14: Remove the MAF sensor (8) from the factory housing using a T15 Torx driver.

Step 15: Using a T20 torx driver, install the MAF sensor into the aFe intake tube using the supplied M4 screws. (9) Make sure the factory seal is still attached to the MAF sensor.



Figure J

Refer to Figure J for Steps 16-17

Step 16: Install the aFe intake tube into the vehicle. Slide the aFe intake tube into the filter and then into the coupling on the throttle body.

Step 17: Align the aFe intake tube correctly then tighten all the clamps.



Figure K

Refer to Figure K for Steps 18-20

Step 18: Attach the two crankcase breather hoses to the aFe intake tube on both passenger and driver side. ⑩

Step 19: Reconnect the MAF sensor harness ⑪.

Step 20: Check all the components are tight and secure. Your installation is now complete. Thank you for choosing aFe POWER!

NOTE: Check all screws, clamps, and connectors are secure after 100-200 miles.



Pro DRY S Air Filter Inv.



P/N: 21-91120

Pro 5R Air Filter Inv.



P/N: 24-91120

Pro-GUARD 7 Air Filter Inv.



P/N: 72-91120

Pre-Filter



P/N: 28-10033

Pro DRY S Restore Kit



P/N: 90-59999

Blue Squeeze Restore Kit



P/N: 90-50501

Gold Squeeze Restore Kit



P/N: 90-50500

Sprinter Booster



P/N: 77-14003

SCORCHER PRO Tune



P/N: 77-34004

SCORCHER PRO



P/N: 77-34008

Silver Bullet TBS 5.3L



P/N: 46-34008

Silver Bullet TBS 6.2L



P/N: 46-34016