

advanced FLOW engineering Magnum Force Stage-2 Air Intake system

Instruction Manual P/N: 54-13041D / 54-13041R

Make: Chevrolet

Model: Corvette (C7)

Year: 2014-2019

Engine: V8-6.2L

Includes Grand Sport Models.



- Please read the entire instruction manual before proceeding.
- Ensure all components listed are present.
Ensure you have all necessary tools before proceeding.
- Do not attempt to work on your vehicle when the engine is hot.
- Disconnect the negative battery terminal before proceeding.
- Retain factory parts for future use.

Label	Qty.	Description	Part Number
A1	1	Air Filter (Pro 5R)	24-90115
A2	1	Air Filter (Pro DRY S)	21-90115
B	1	Tube, Rotomold	05-5413041B1
C	1	Housing Rotomold	05-5413041B2
D	1	Coupling, Silicone Bellow 3-7/8"	05-01375
E	2	Clamp, #060	03-50002
F	1	Seal, Trim (30.5" long)	05-01507
G	2	Vent Fitting, Aluminum	05-01338
H	2	Screw, Torx T20 M4 x .7x8	03-50491
I	1	Threadlocker	03-50162
J	1	Plug, Hex Socket: 1/8" NPT	03-50410
K	2	Clamp, Mini #006	03-50025
L	1	Hose, Coolant 3/8" ID (15")	05-01357
M	1	Ties, Nylon Cable	05-60167

Installation will require the following tools:

7mm, 8mm and 10mm Socket or nut driver, Ratchet and extension, flat head screw driver, Razor Blade, Torx T20 Driver.

Emissions Disclaimer: This product is not currently CARB exempt and is not available for purchase in California or for use on any vehicle registered with the California Department of Motor Vehicles.

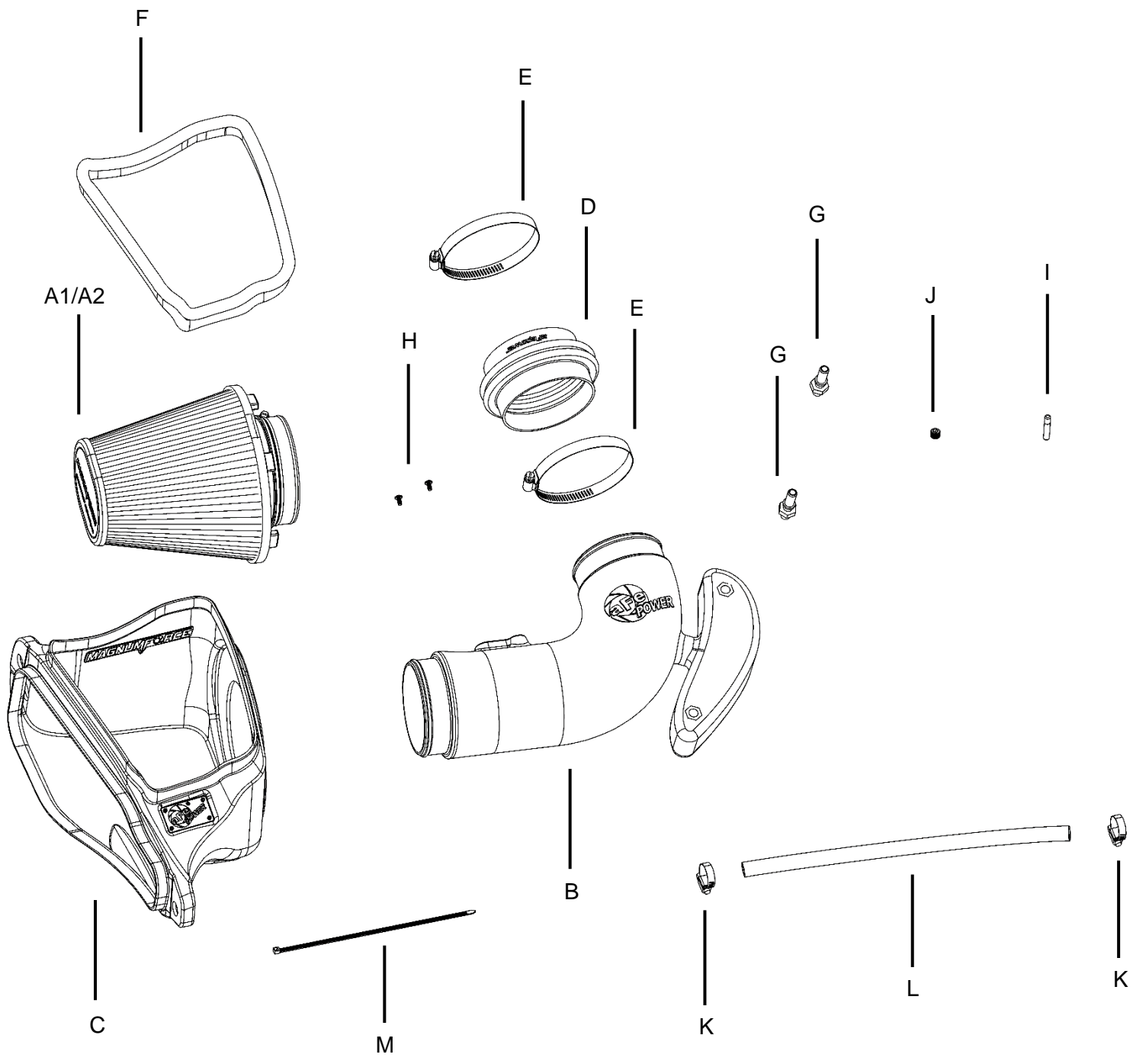

**Figure A****Refer to Figure A for Steps 1**

Step 1: Remove the radiator air outlet channel by removing the four screws securing it with a 7mm socket or nut driver.

**Figure B****Refer to Figure B for Step 2-3**

Step 2: Disconnect the Mass Air Flow (MAF) Sensor harness.

Step 3: Loosen the clamps at the throttle body and at the housing. Disconnect both vent hoses then remove the factory intake tube out of the vehicle. (Some vehicles are equipped with only one vent hose connection.)

**Figure C****Refer to Figure C for Step 4**

Step 4: Remove the two 10mm screws holding the factory intake box and pull it out of the mounting grommet then out of the vehicle. Those screws will be re-used for the installation of the aFe POWER intake.

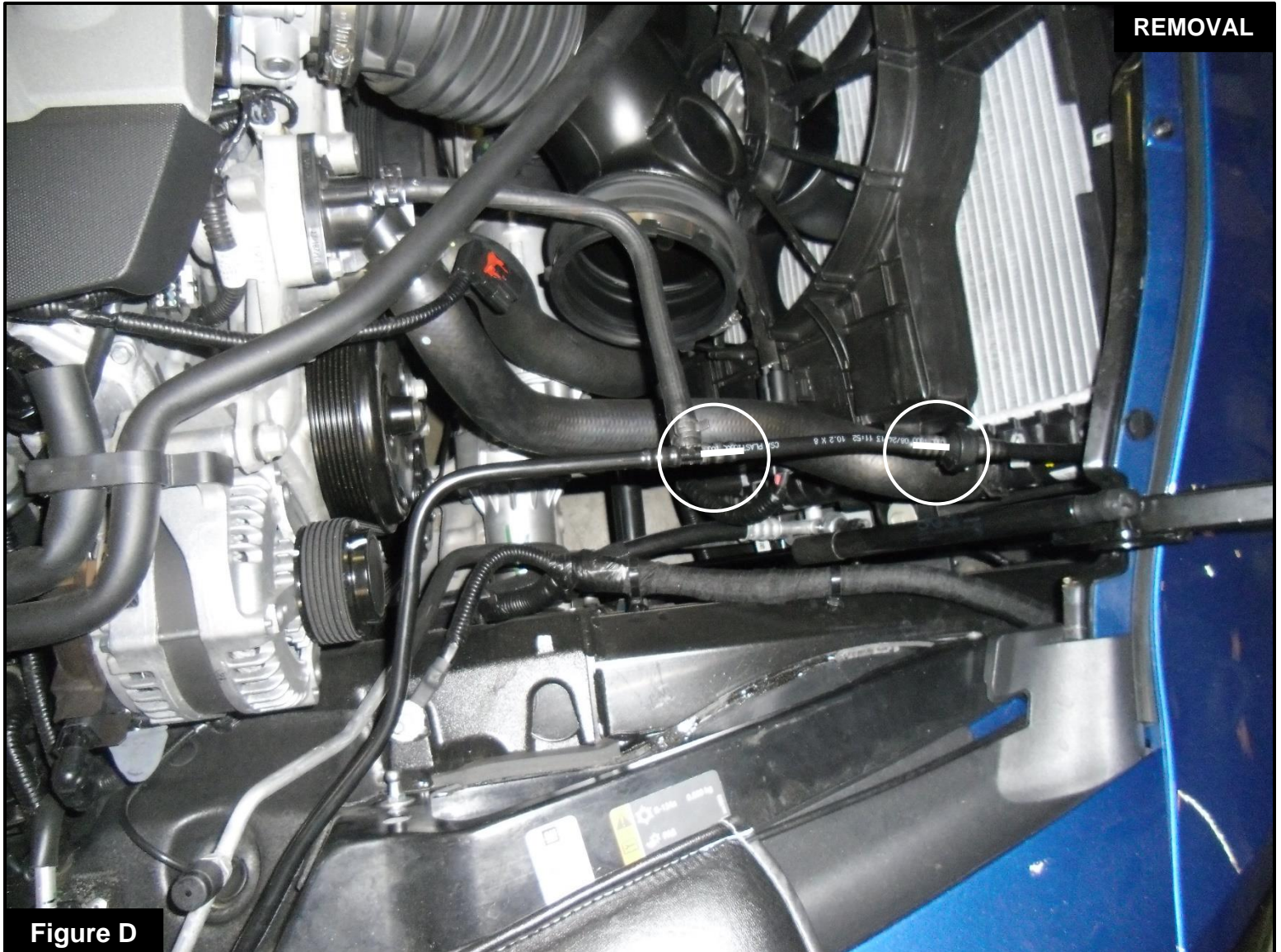

Refer to Figure D for Steps 5-6

Make sure engine is cold before disconnecting the coolant line.

Step 5: The coolant line needs to be re-routed to make clearance for the hood vent. Locate the short hard plastic coolant line between the check valve and the T-fitting. Put a shop towel under it to catch the coolant excess when disconnected.

Step 6: With a sharp blade, slice open the hard plastic coolant line on both sides and remove it.

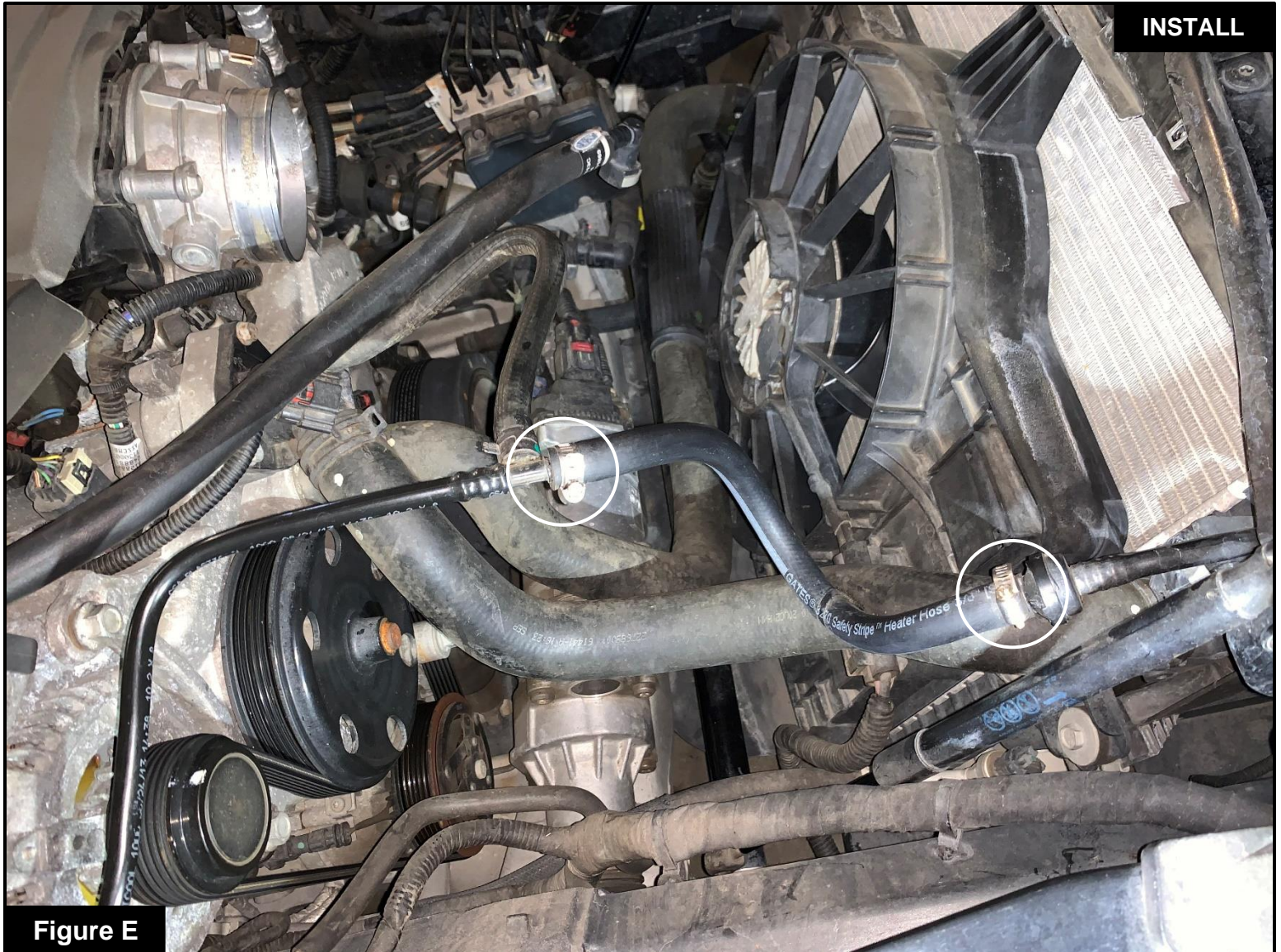

Figure E

Refer to Figure E for Steps 7

Step 7: Replace the hard plastic line with the furnished coolant hose. Install the provided mini clamps on both ends to secure it. The hoses can run over the intake or under the intake. Use the furnished cable tie to secure the coolant line to the vent hose and prevent any contact with the serpentine belt.

**Figure F****Refer to Figure F for Step 8-9**

Step 8: Remove the filter clamp from the aFe Power air filter. Slide the aFe Power air filter into the aFe POWER housing from the top opening. Then guide the filter flange through the round opening in the housing and snap in the filter. Place the filter clamp on the filter flange but do not tighten yet.

Step 9: Install the seal trim on the top edge of the aFe Power housing.



Figure G

Refer to Figure G for Steps 10

Step 10: Transfer the three mounting grommets from the factory air box to the aFe POWER Housing.



Figure H

Refer to Figure H for Steps 11

Step 11: Install the aFe POWER filter/housing assembly into the vehicle. Push it on the factory stud and secure it using the two factory 10 mm screws removed at step 4.

**Figure I****Refer to Figure I for Steps 12-14**

Step 12: Remove the MAF sensor from the factory air box. Install it on the aFe POWER tube using factory O-ring and supplied M4 screws.

Step 13: Screw the two vent fittings into the aFe POWER tube. Apply some of the furnished threadlocker to assure a perfect seal. If vehicle is equipped with only one vent fitting, use the supplied NPT plug to block off the extra hole.

Step 14: Install the silicone bellow coupling and the clamps on the tube end. Do not tighten clamps yet.



Figure J

Refer to Figure J for Steps 15-17

Step 15: Install the aFe POWER tube into the vehicle. Slide the tube first into the filter then the coupling over the throttle body. Align the tube correctly then tighten all clamps. The coolant hose can run over the intake or under the intake. Secure it away from the pulley with the supplied cable tie.

Step 16: Reconnect the MAF sensor.

Step 17: Reconnect the vent hoses onto the aluminum fittings.

**Figure K****Refer to Figure K for Steps 18-19**

Step 18: Re-install the factory radiator air outlet.

Step 19: Make sure all clamps and connections are secured. Your installation is now complete.

NOTE: Check all bolts, clamps, and connectors after 100-200 miles.



Pro DRY S Air Filters



P/N: 21-90115

Pro 5R Air Filters



P/N: 24-90115

Pre-Filter



P/N: 28-10113

Pro DRY S Restore Kit



P/N: 90-59999

Blue Squeeze Restore Kit



P/N: 90-50501

Throttle Body Spacer



P/N: 46-34011

Sprintbooster Power Converter



P/N: 77-14007

[View other performance air intake systems made by aFe on our website.](#)