

advanced FLOW engineering Magnum FORCE Stage-2 Cold Air Intake System

Instruction Manual P/N: 54-13039D / 54-13039R

Make: Ford

Model: Mustang GT

Year: 2018-2019

Engine: V8-5.0L (Coyote)



- Please read the entire instruction manual before proceeding.
- Ensure all components listed are present.
- Ensure you have all necessary tools before proceeding.
- Do not attempt to work on your vehicle when the engine is hot.
- Disconnect the negative battery terminal before proceeding.
- Retain factory parts for future use.

Label	Qty.	Description	Part Number
A1	1	Air Filter (Pro 5R)	24-91037
A2	1	Air Filter (Pro DRY S)	21-60507
B	1	Tube	05-5413039B1
C	1	Housing	05-5413015B2
D	1	Coupling, Silicone Bellows (3.5"ID x 3.75"ID) x 3"L	05-01508
E	1	Fitting, Vent Tube: Ford F-150 (Small)	05-01338
F	1	Fitting, Vent Tube: Ford F-150 (Large)	05-01339
G	1	Cap, Vinyl 1"-1-1/16" OD	03-50623
H	1	Clamp, 056 (3-1/16" – 4")	03-50009
I	1	Clamp, 060 (3-5/16" – 4-1/4")	03-50002
J	2	Screw, Torx: M4	03-50490
K	1	Seal, Trim (42" Length)	05-00072
L	2	Washer, Lock: M6	03-50071
M	2	Washer, Flat: M6	03-50070
N	2	Screw, Hex Hd: M6x16	03-50052

Installation will require the following tools:

T20 Torx Driver, 8mm Nut Driver, 10mm Nut Driver, Pliers, Flat Head Screw Driver and an adjustable wrench.

Emissions Disclaimer: This product is not currently CARB exempt and is not available for purchase in California or for use on any vehicle registered with the California Department of Motor Vehicles.

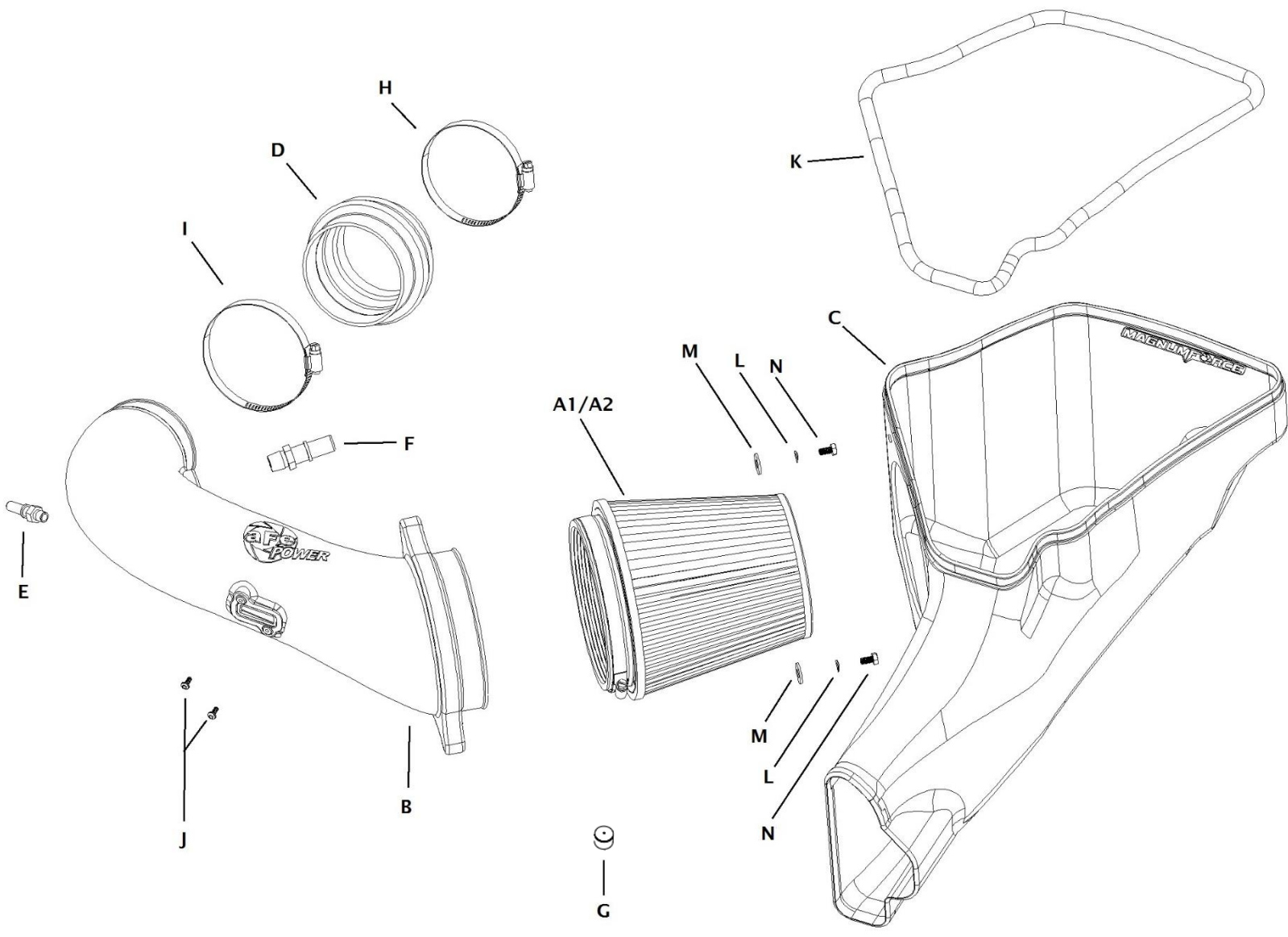



Figure A

Refer to Figure A for Steps 1-3

Step 1: Unclip the two circular caps on the engine cover and remove the two M6 nuts (1) using a 10mm nut driver. Pull up on the engine cover to remove it.

Step 2: Locate the two factory clamps (2) on the stock intake tube. Using an 8mm nut driver, loosen the clamps at the housing and throttle body.

Step 3: Find the two vacuum lines (3) on the front and back of the intake tube and disconnect them.

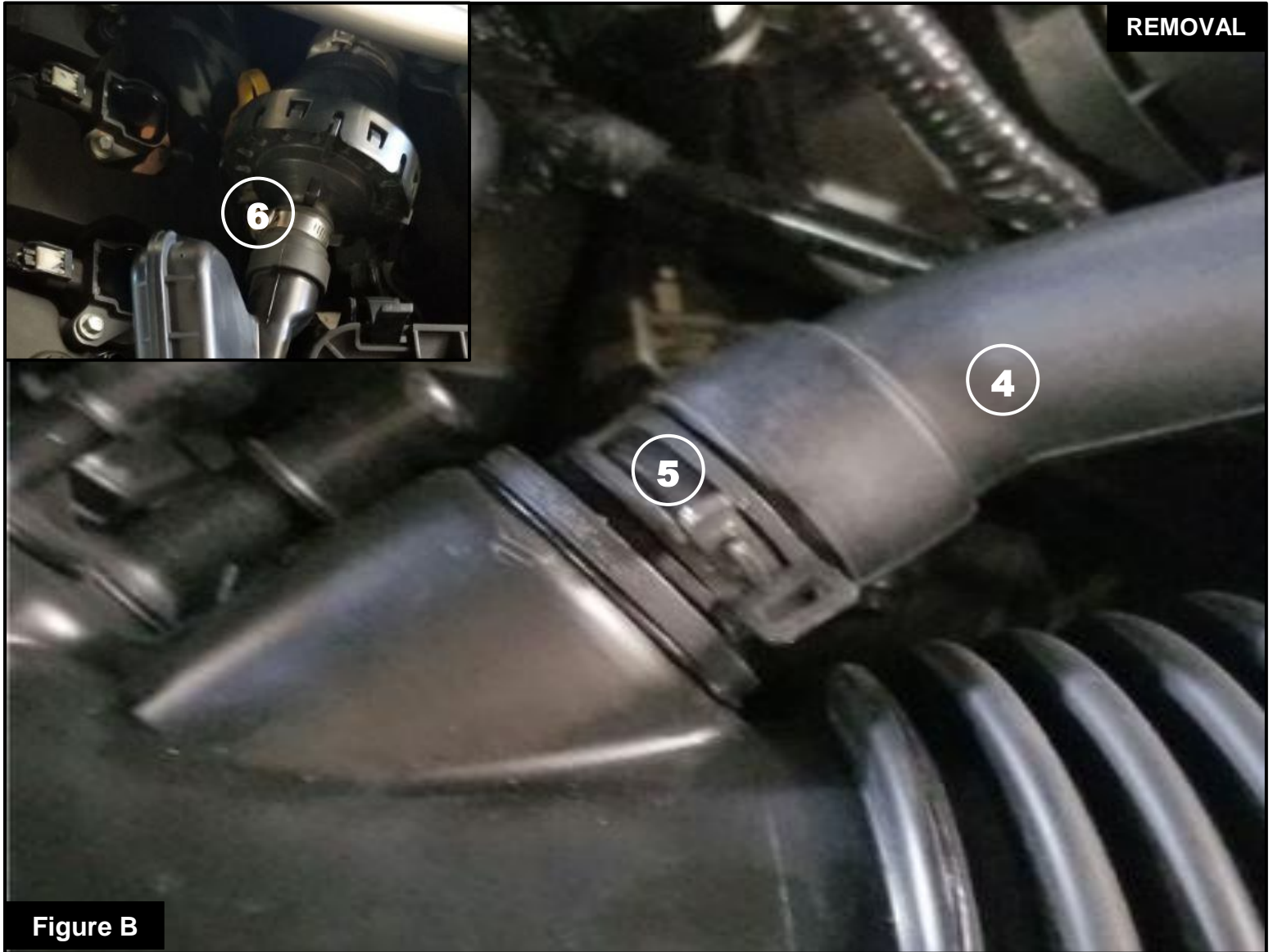

Figure B

Refer to Figure B for Steps 4-6

Step 4: Locate the sound tube (4) attached to the intake by a black spring clamp (5).

Step 5: Using a pair of pliers, remove the black spring clamp.

Step 6: Using a flat-head screw-driver, separate the pinch clamp (6) then remove the front half of the sound tube attached to the chamber near the shock tower.

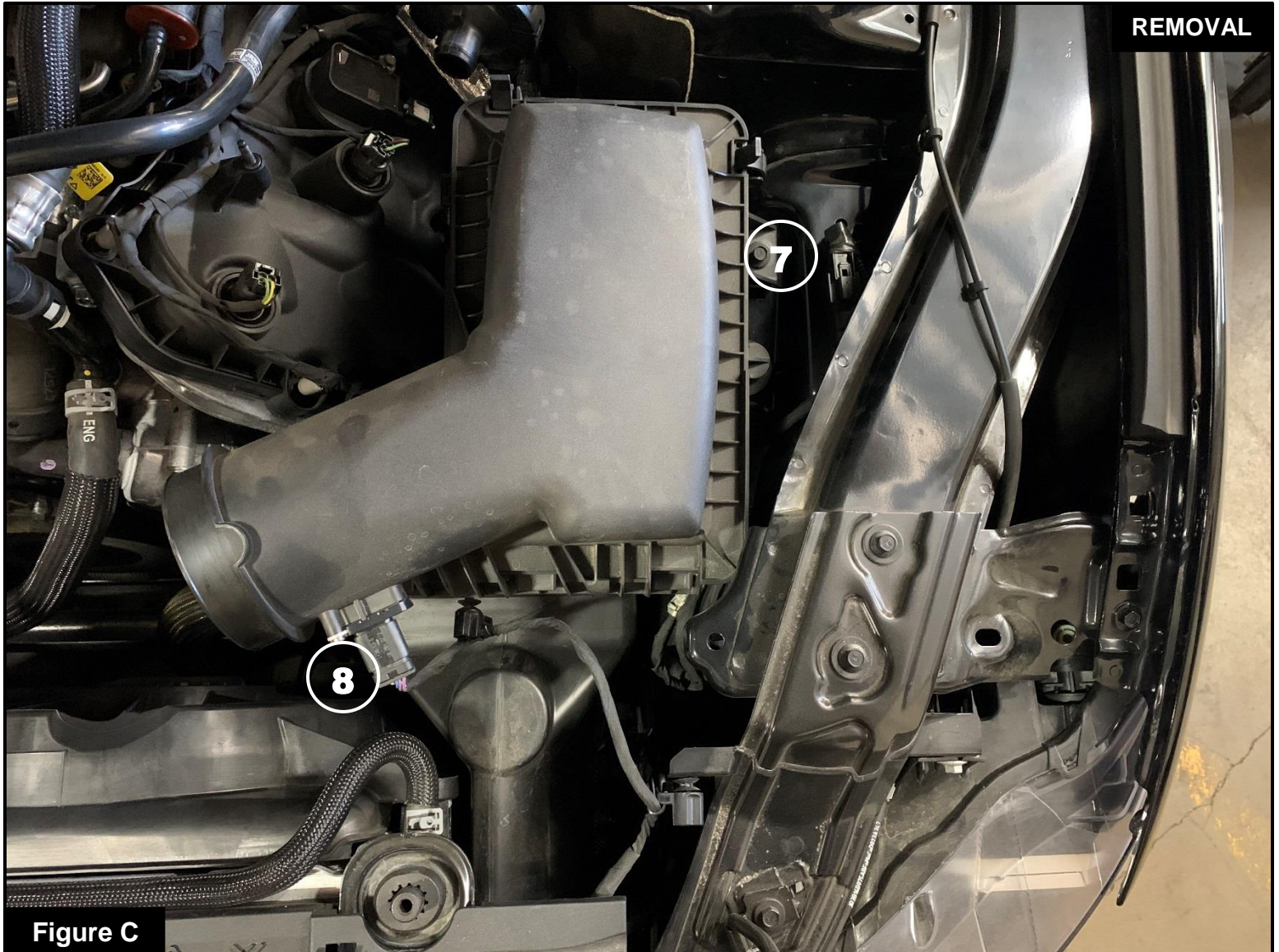

Figure C

Refer to Figure C for Steps 7-8

Step 7: Using a 10mm nut driver, remove M6 screw (7) securing the housing and set aside for later use.

Step 8: Disconnect the MAF sensor clip (8), then pull up on the housing to remove it from the vehicle.

**Figure D****Refer to Figure D for Step 9**

Step 9: Install the 2 supplied vent fittings (9) into their respective locations on the aFe Power intake tube and tighten them using an adjustable wrench.



Figure E

Refer to Figure E for Steps 10 - 11

Step 10: Using a 10mm nut driver, attach the aFe Power intake tube to the aFe Power housing using the supplied hardware (10) with the flat washer, lock washer, and screw in that order.

Step 11: Install the provided trim-seal (11) onto the top of the housing.



Refer to Figure F for Step 12

Step 12: Remove the grommets (12) from the stock housing and transfer them into the respective locations on the aFe Power housing.

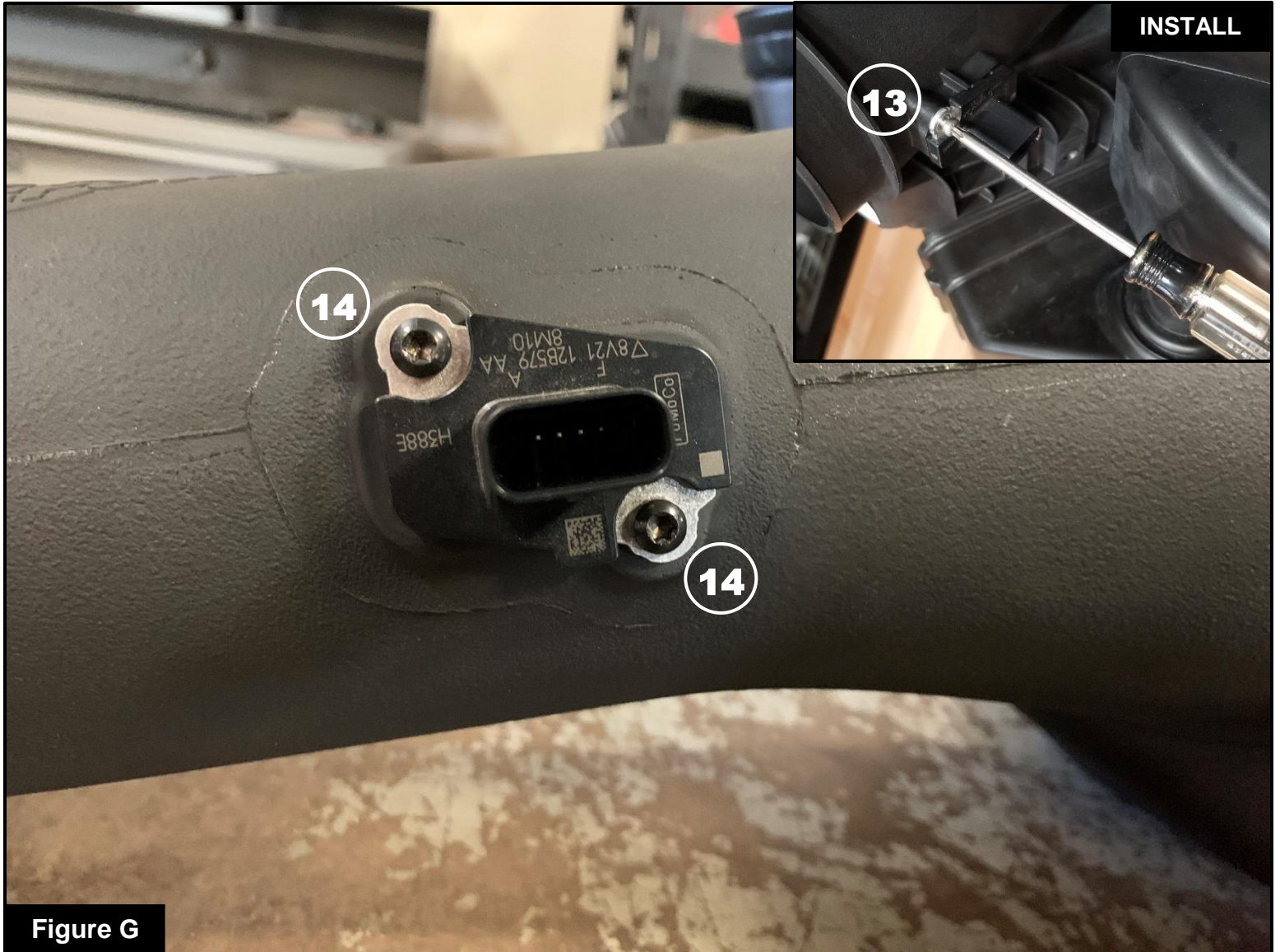

Figure G

Refer to Figure G for Steps 13-14

Step 13: Using a T20 torx driver, remove the 2 screws (13) holding the MAF into the stock housing.

Step 14: Install the MAF into the aFe Power intake tube using the 2 supplied M4 screws (14).

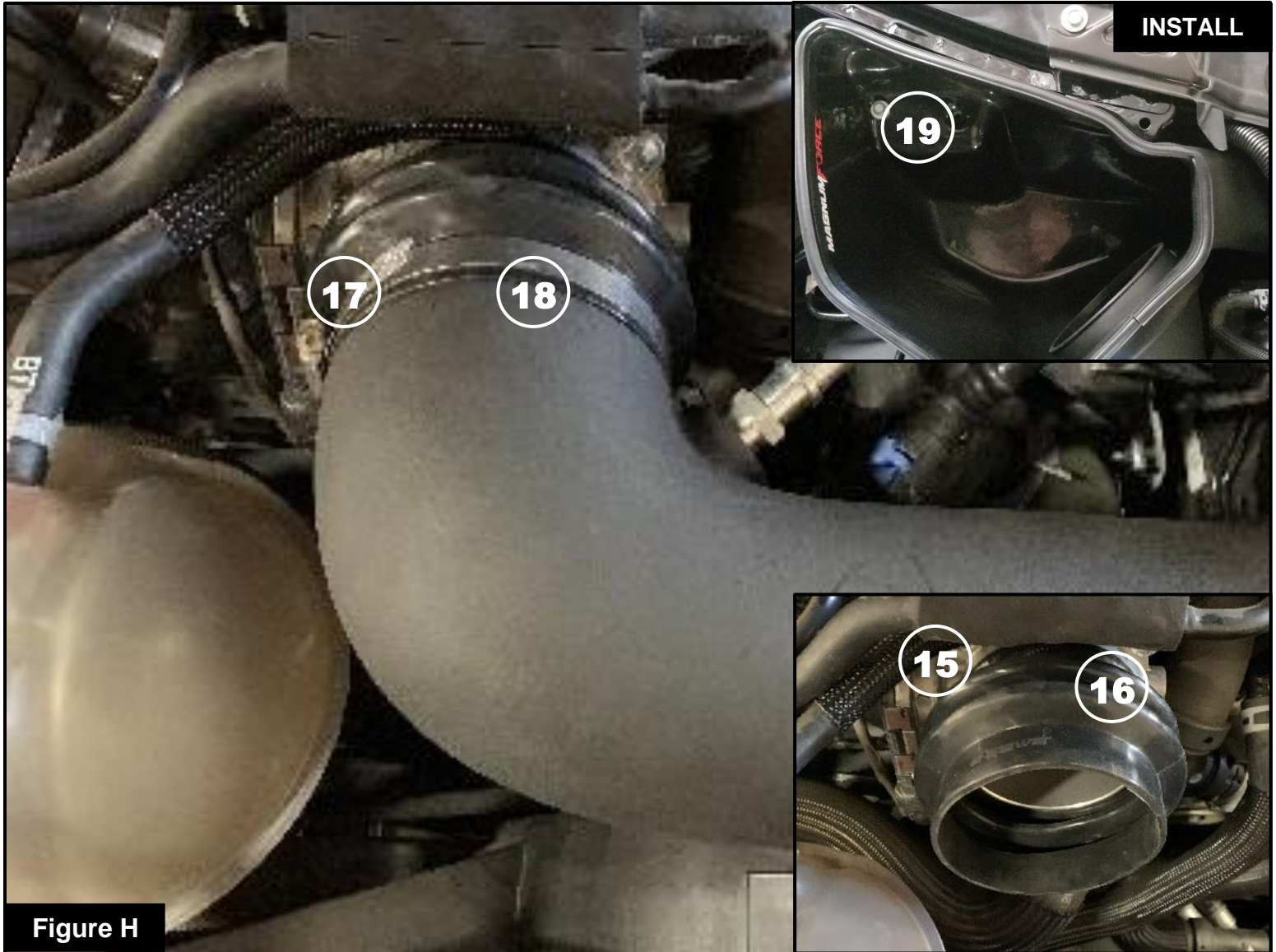

Figure H

Refer to Figure H for Steps 15-17

Step 15: Slip the supplied #056 clamp (15) and smaller side of the coupling (16) over the throttle body and tighten clamp using an 8mm nut driver.

Step 16: Install the #060 clamp (17) over the larger end of the coupling (18). Now install the aFe Power housing and tube assembly into the vehicle and slip the end of the tube into the larger end of the coupling. Tighten the #060 clamp using and 8mm nut driver.

Step 17: Use the M6 screw (19) you set aside earlier and install it into the grommet on the inside edge of the aFe Power housing and tighten using a 10mm nut driver.

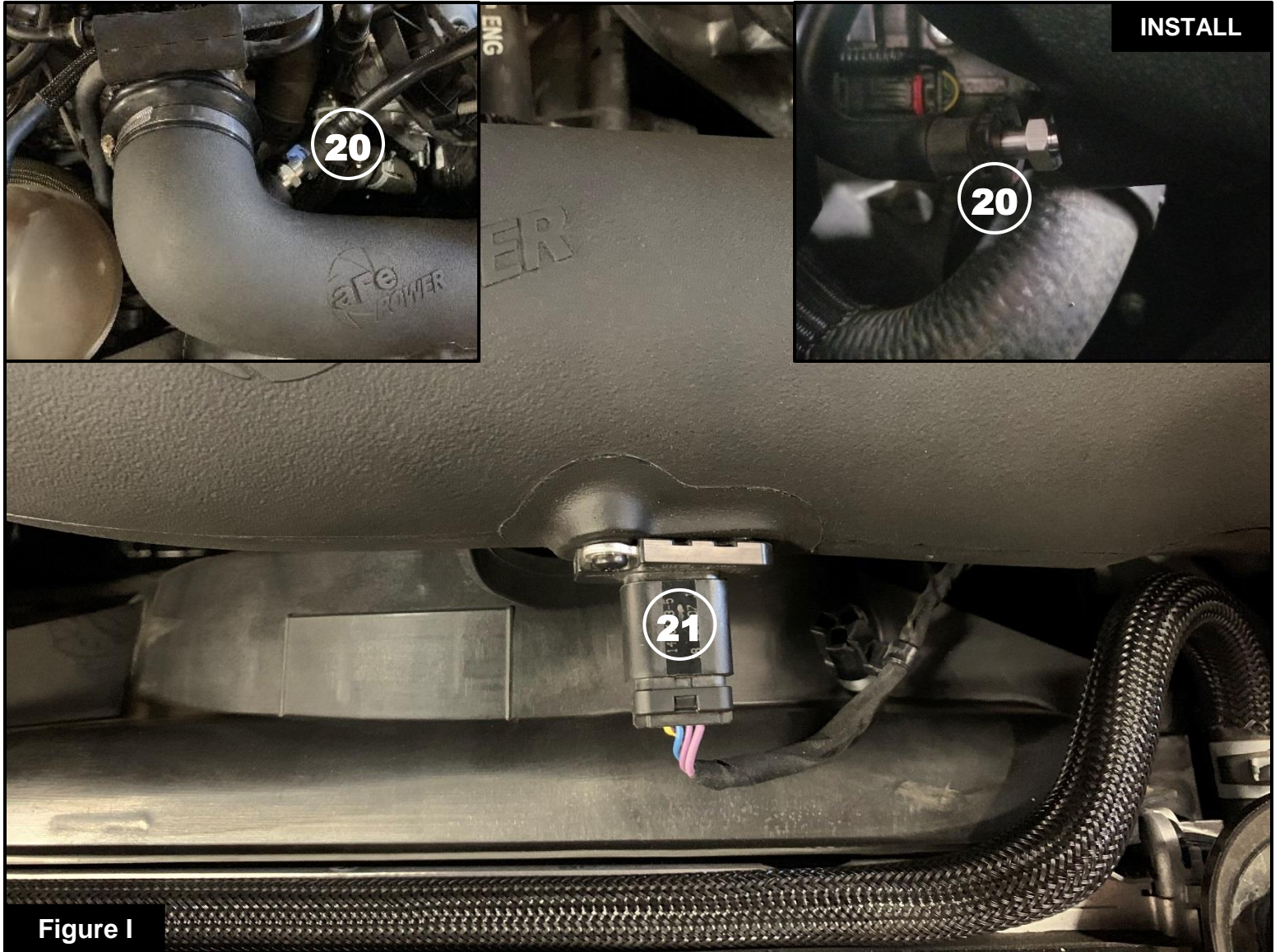

Figure I

Refer to Figure I for Steps 18-19

Step 18: Install the 2 vacuum lines (20) that were disconnected earlier and ensure that they are secure.

Step 19: Re-connect the MAF sensor (21) with the red tab facing down.

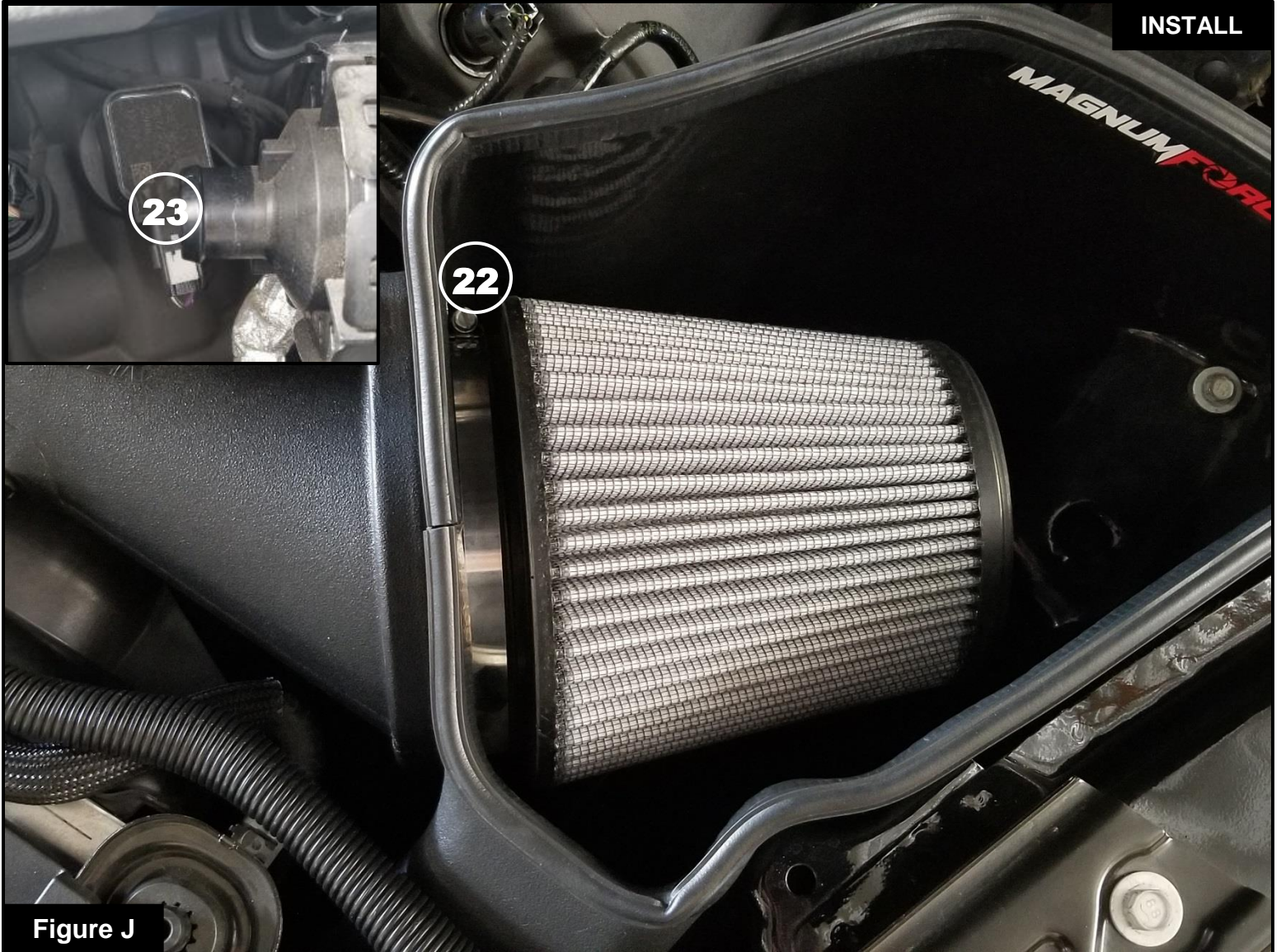

Figure J

Refer to Figure J for Steps 20-21

Step 20: Install the filter and clamp (22) onto the larger end of the tube and tighten clamp using an 8mm nut driver.

Step 21: Slip the supplied vinyl cap (23) over the sound chamber snout.



Figure K

Refer to Figure K for Steps 22-23

Step 22: Re-attach the engine cover. Install and tighten the two M6 nuts you removed earlier using a 10mm nut driver. Clip the two circular caps you removed in the first step back into their respective locations.

Step 23: Check that all components are tight and secure. Your installation is now complete. Thank you for choosing aFe POWER!

NOTE: Check all bolts, clamps, and connectors after 100-200 miles.