

**MAGNUM FORCE**

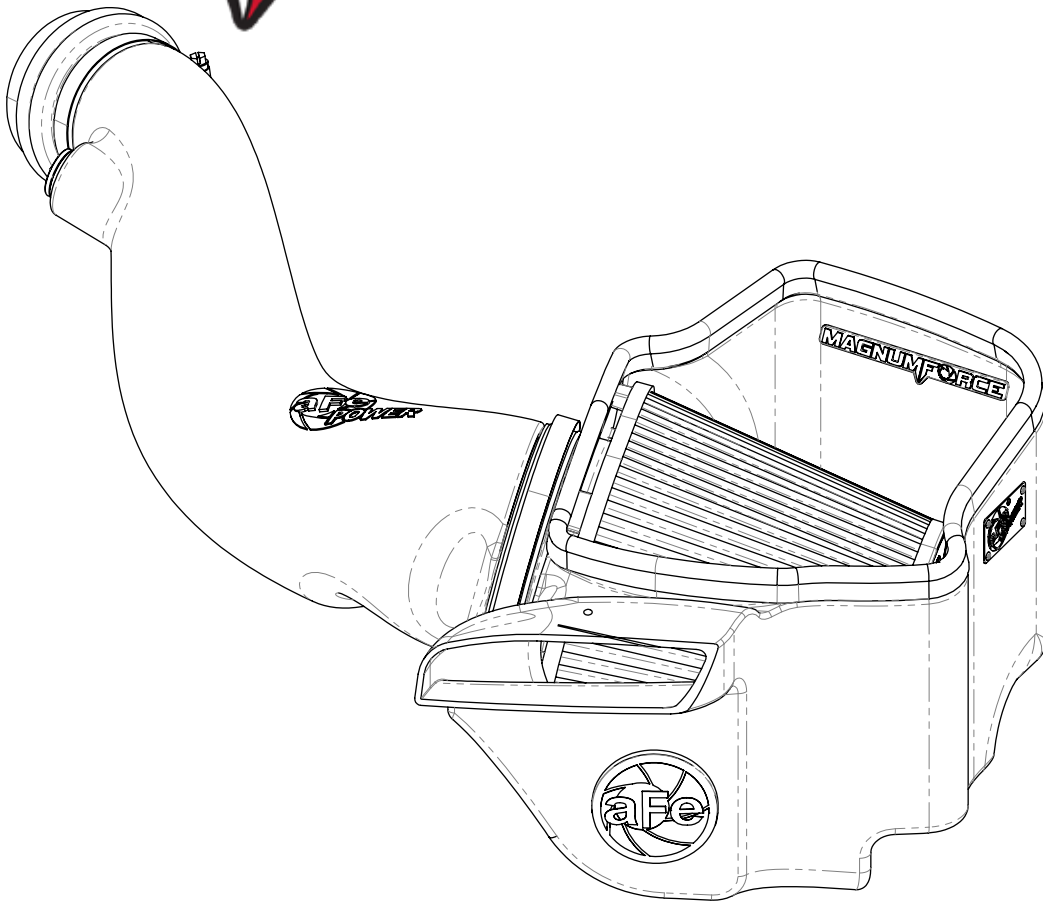

**advanced FLOW engineering** Magnum FORCE Stage-2 Cold Air Intake System

**Instruction Manual** P/N: 54-13035D / 54-13035R

Make: **Jeep** Model: **Grand Cherokee (WK2)** Year: **2016-2019**  
Make: **Dodge** Model: **Durango** Year: **2016-2019**

Engine: **V6-3.6L**  
Engine: **V6-3.6L**



- Please read the entire instruction manual before proceeding.
- Ensure all components listed are present.
- If you are missing any of the components.
- Ensure you have all necessary tools before proceeding.
- Do not attempt to work on your vehicle when the engine is hot.
- Disconnect the negative battery terminal before proceeding.

## Retain factory parts for future use.

Label	Qty.	Description	Part Number
A1	1	Air Filter (Pro DRY S)	21-91146
A2	1	Air Filter (Pro 5R)	24-91146
B	1	Tube	05-5413035B1
C	1	Housing	05-5413023B2
D	1	Plug, Silicone	05-01482
E	1	Fitting, Air Temp. Sensor	05-01454
F	1	Coupling, Silicone, Bellow Reducer	05-01400
G	1	Grommet	03-50167
H	2	Clamp, #052	03-50008
I	1	Seal, Trim: 7/16" (34" inches)	05-00072
J	1	Hose, Breather: 1/2"ID x 30"L	05-01422

**Tools Required:** Flat head screwdriver, 8mm & 10mm nut drivers.  
Recommended: Panel popper.

**Emissions Disclaimer:** This product is not currently CARB exempt and is not available for purchase in California or for use on any vehicle registered with the California Department of Motor Vehicles.

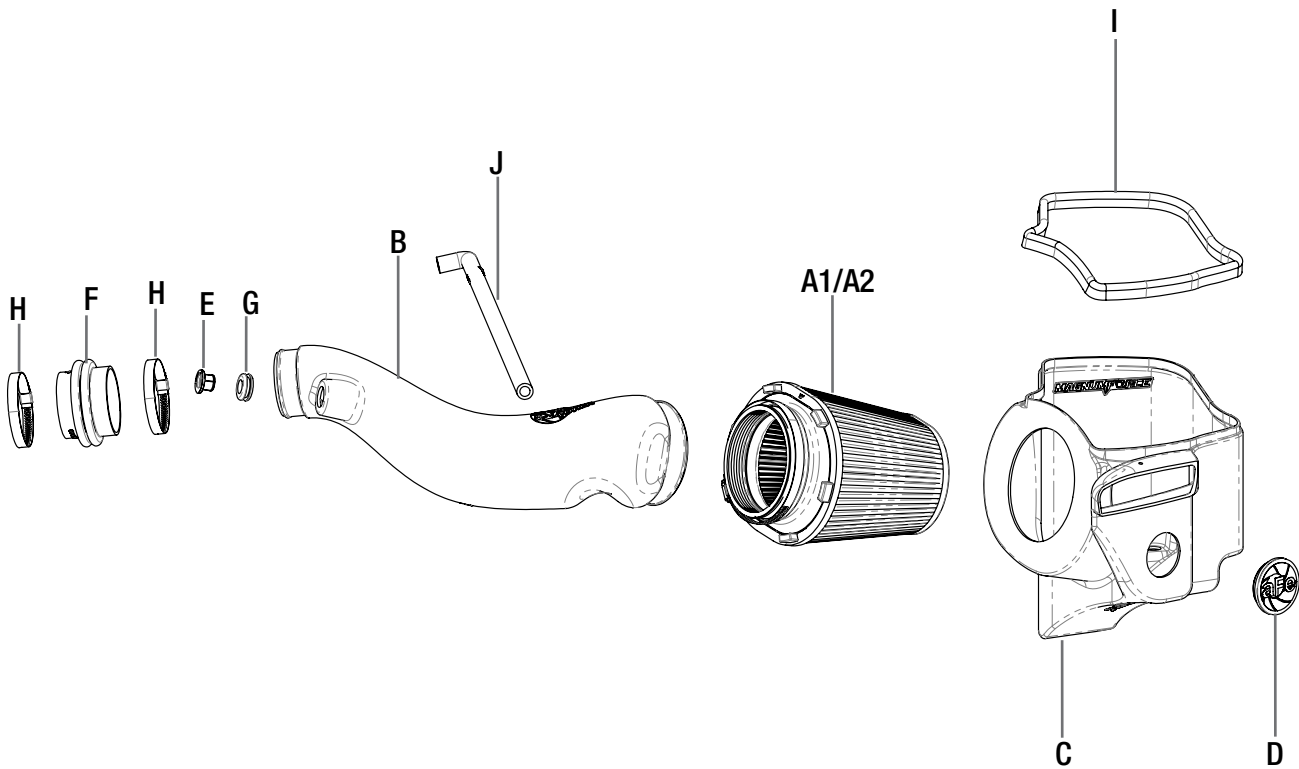

**Figure A****Refer to Figure A for Steps 1-2**

Step 1: Pull up on the cover. ①

Step 2: With the 10mm nut driver, remove the factory screw ②, then carefully pull off the engine cover.

**Figure B****Refer to Figure B for Steps 3-7**

Step 3: Disconnect the temperature sensor harness from the temperature sensor by pinching and firmly pulling away (3).

Step 4: Detach the temp sensor harness from the factory intake (4).

Step 5: Remove the crank-case vent (CCV) hose from the factory airbox and tuck out of the way. (5)

Step 6: With the 8mm nut driver, loosen the band clamp at the throttle body. (6)

Step 7: If equipped, unclip the vent hose on the backside of the factory airbox.

**Figure C****Refer to Figure C for Steps 8-9**

Step 8: Carefully pull up and remove the trim seal on top of the factory intake scoop, along with 1-2 clips on either side. This helps with removing the factory airbox and installation of the aFe POWER housing. ⑦

**Note: It may help to use a panel popper when pulling the clips.**

Step 9: Pull the factory intake tube off the throttle body and pull up to remove the entire factory intake.



### **Refer to Figure D for Steps 10-12**

Step 10: Transfer the three factory rubber grommets from the factory airbox to the aFe POWER housing as shown in Figure 1. (8)

Step 11: Pre-assemble the aFe POWER housing by inserting the aFe POWER filter. (9)

Step 12: Install the supplied trim seal on the aFe POWER housing. (10)

**Figure E****Refer to Figure E for Steps 13-14**

Step 13: If desired, install the supplied aFe POWER plug. ⑪

Step 14: Install the housing assembly into the vehicle.

**NOTE:** Without the plug installed, the aFe POWER intake will capture the maximum air available. More airflow offers more power. Some of this air is picked up from inside the engine compartment and could be warmer air. Warmer air will affect the performance of the vehicle.



**Figure F****Refer to Figure F for Step 15**

Step 15: Pre-assemble the aFe POWER intake tube by inserting the supplied rubber grommet and temp sensor fitting. Transfer the temp sensor ⑫ from the factory tube to the fitting on the aFe POWER tube. Turn the temp sensor clockwise until it locks in place.

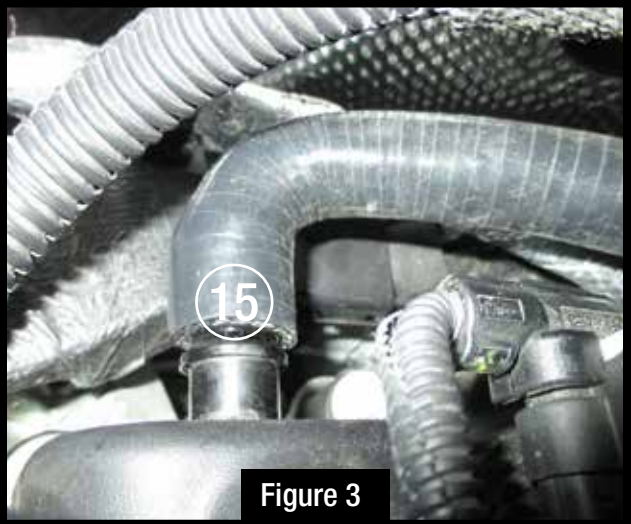
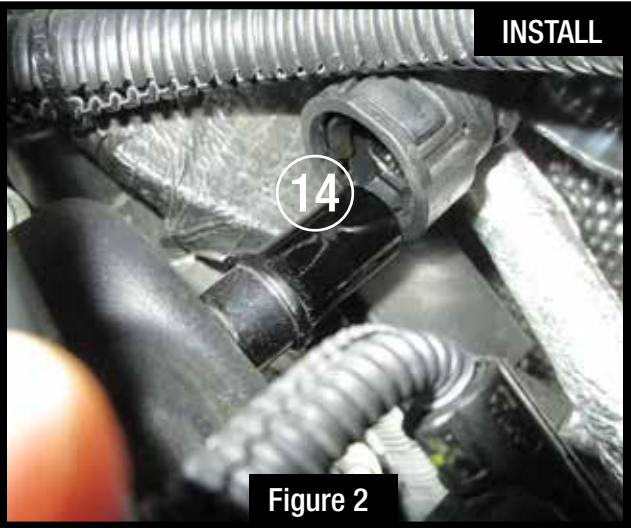

**Refer to Figure G for Steps 16-18**

Step 16: Follow the factory crankcase hose to the rear of the engine (13).

Step 17: Disconnect the hose from its mounting location (14) as shown in Figure 2.

Step 18: Once the factory crankcase hose is disconnected, replace it with the supplied aFe POWER hose by slipping the shorter end of the hose at the rear of the engine (15) as shown in Figure 3.

**Figure H****Refer to Figure H for Steps 19-20**

Step 19: Install the supplied coupling over the throttle body. Slide one clamp over the throttle body.

Tighten the clamp using an 8mm nut driver (16).

Step 20: Slip the other supplied clamp over the other end of the coupling, but do not tighten at this time.

**Figure I**
**Refer to Figure I for Steps 21-26**

Step 21: Insert tube into filter first. Then, rotate tube down and insert the other end into the coupling.

Align the tube to the filter and coupling, then tighten all clamps.

Step 22: Reconnect the temp sensor harness. (17)

Step 23: Connect CCV hose to aFe POWER tube. (18)

Step 24: Re-install rubber trim seal into factory locations and onto the aFe POWER housing. (19)

Step 25: Re-install engine cover.

Step 26: Check all the components are tight and secure. Your installation is now complete. Thank you for choosing aFe POWER.

**NOTE: Check all bolts, clamps, and connectors after 100-200 miles.**