

advanced FLOW engineering Magnum Force Stage-2 Air Intake System

Instruction Manual P/N: 54-12852R / 54-12852D

Make: Dodge **Model:** Challenger SRT Hellcat

Year: 2017-2020

Engine: V8-6.2L(sc)

Make: Dodge **Model:** Charger SRT Hellcat

Year: 2017-2020

Engine: V8-6.2L(sc)



- Please read the entire instruction manual before proceeding.
- Ensure all components listed are present.
- Ensure you have all necessary tools before proceeding.
- Do not attempt to work on your vehicle when the engine is hot.
- Retain factory parts for future use.

Label	Qty.	Description	Part Number
A1	1	Air Filter (Pro 5R)	24-91068
A2	1	Air Filter (Pro DRY S)	21-91068
B	1	Tube	05-12852B1
C	1	Housing	05-12802B2
D	1	Male / Female Isolation Mount	03-50206
E	3	Lock Washer	03-50071
F	3	M6 Screws	03-50052
G	3	Flat Washer	03-50070
H	1	Clamp, T-Bolt (4-1/8" – 4-1/2") (SS)	03-50262
I	1	Clamp, T-bolt (4-9/16" - 4-7/8") (SS)	03-50319
J	1	Isolation Pad	03-50196
K	1	Coupling, Silicone Bellow	05-01495
L	1	Seal Trim (25" Length)	05-00072
M	1	Seal Trim (16.5" Length)	05-00072
N	1	Rubber Edge Trim (12.5" Length)	05-00149
O	1	Grommet, Rubber	03-50167
P	1	Fitting, Air temp sensor	05-01454
Q	2	Spring Clamp, 15/16" Hose (For 19-20 Models Only)	03-50646
R	1	Silicone Hose 1/2" ID (20" Length) (For 19-20 Models Only)	05-01396
S	1	Elbow Fitting (For 19-20 Models Only)	03-50165
T	1	Easy-install Snap-Grip Clamp (For 19-20 Models Only)	03-50648

Installation will require the following tools: 8mm and 11mm nut driver or socket, flat screwdriver, blade and pliers.

Emissions Disclaimer: This product is not currently CARB exempt and is not available for purchase in California or for use on any vehicle registered with the California Department of Motor Vehicles.

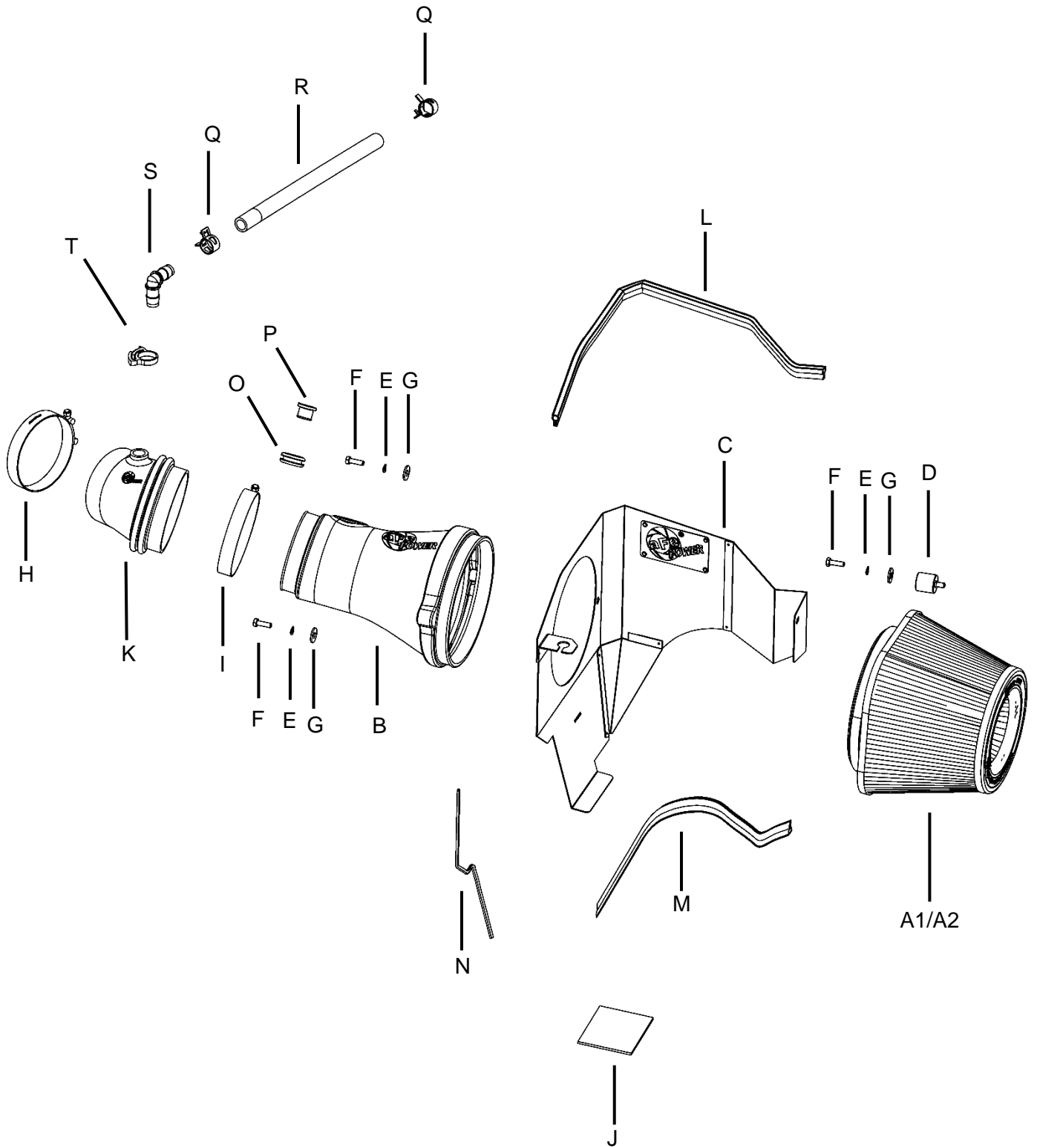

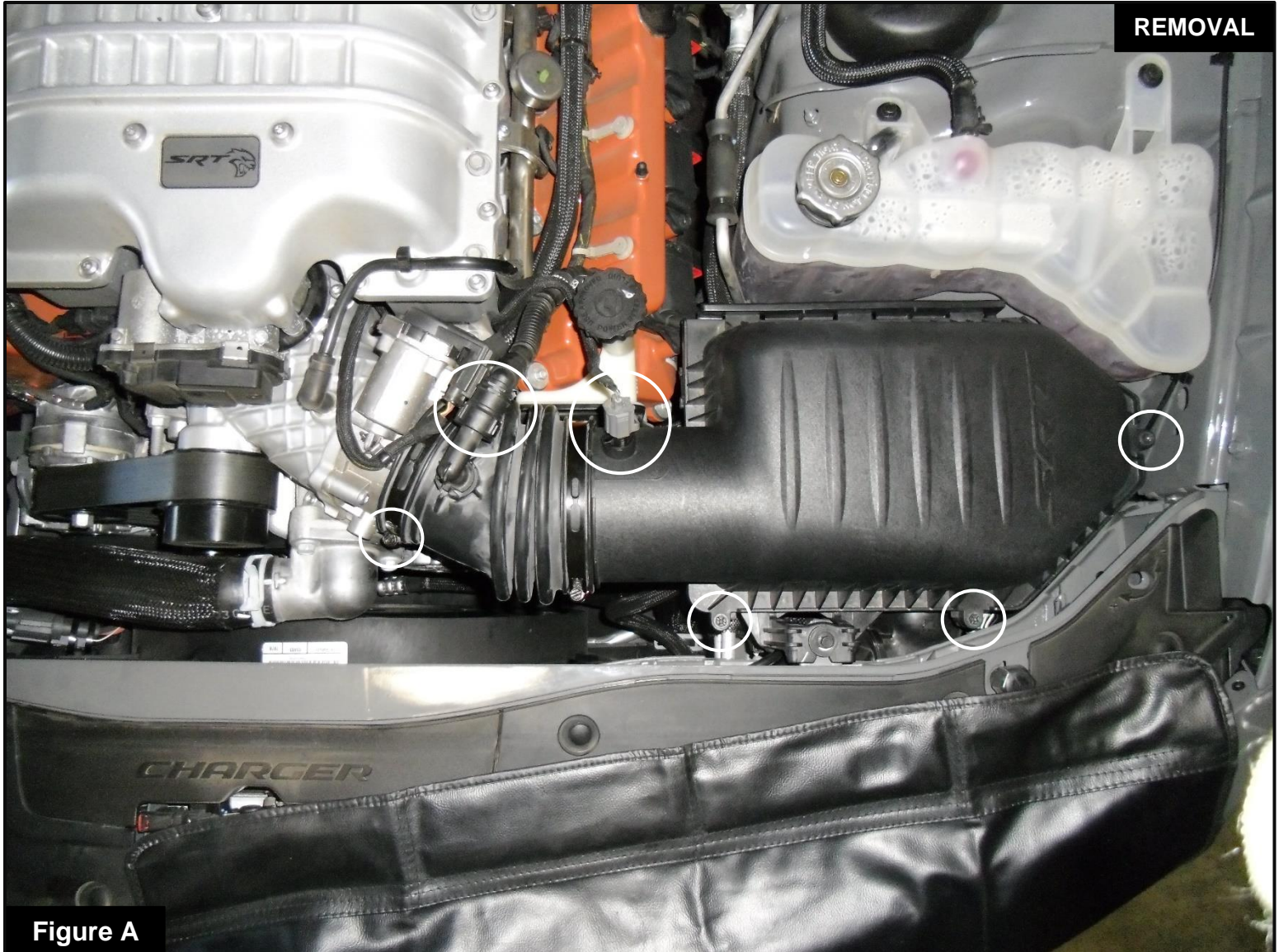

Figure A

Refer to Figure A for Steps 1-4:

Step 1: Disconnect the temperature sensor from the engine harness.

Step 2: **(For 17-18 Models ONLY)** Disconnect the 90-degree fitting from the PCV hose.

Step 3: Loosen clamp at the throttle body.

Step 4: Loosen the 3 screws securing the upper portion of the airbox to the lower portion.

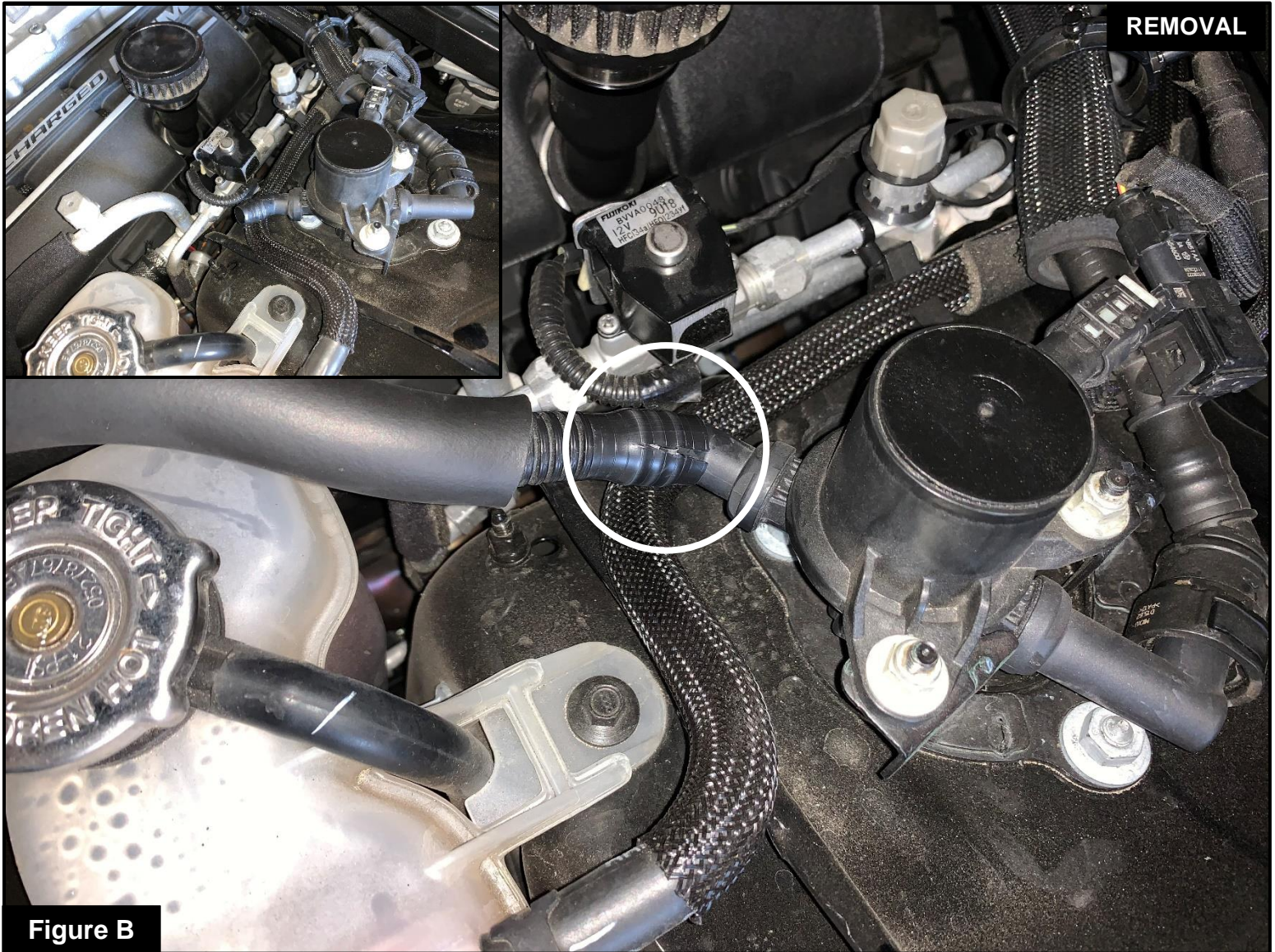

Refer to Figure B for Steps 5-7:

Step 5: **(For 19-20 models ONLY)** Slice the plastic line connected to the MUA system. Try to make the cut as clean as possible, if you ever need to reinstall the factory intake in the future. We suggest to use heat-shrink sleeve to cover the cut if needed.

Step 6: **(For 19-20 models ONLY)** Disconnect the plastic hose from the MUA system. A silicone hose is provided to connect the aFe POWER tube to the MUA system.

Step 7: Remove the upper portion of the factory airbox and the flat panel air filter.

**Figure C****Refer to Figure C for Steps 8-10:**

Step 8: Using an 8mm nut driver, remove the screw securing the factory airbox. This screw will be reused to secure the aFe POWER housing.

Step 9: **(For Challenger Models ONLY)** Remove the lower part of the factory airbox and inlet duct as one piece.

Step 10: **(For Charger Models ONLY)** Disconnect the inlet duct from the factory airbox and pull the lower part of the airbox outside of the vehicle. (The inlet duct is not removable on Charger models)

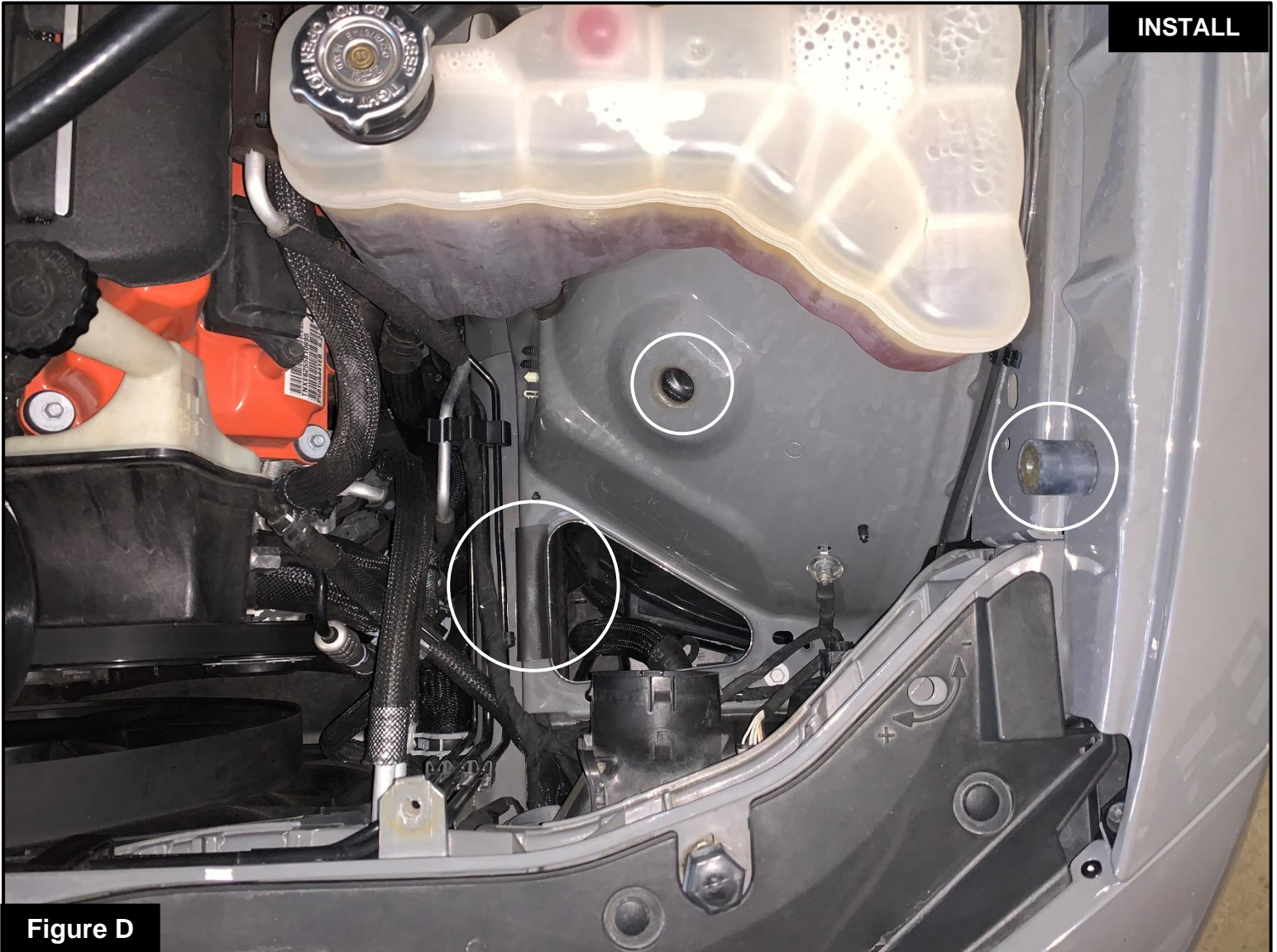

Figure D

Refer to Figure D for Steps 11-13:

Step 11: Remove the 10mm screw from the fender and install the furnished isolation mount into the hole.

Step 12: Remove the factory grommet from the hole on the fender.

Step 13: Install the foam pad on the fender where the aFe POWER housing will rest.

**Figure E****Refer to Figure E for Steps 14-15:**

Step 14: Transfer the metal sleeve and grommet from the factory airbox to the aFe POWER housing.

Step 15: Install the 3 seal trims on the edges of the aFe POWER housing, as shown in Figure E.



Figure F

Refer to Figure F for Step 16:

Step 16: Install the aFe POWER housing into the vehicle. Secure it with the factory screw removed at step 8 and also secure it to the isolation mount using the furnished M6 screw, lock washer, and flat washer.



Refer to Figure G for Steps 17-18:

Step 17: Remove the temperature sensor from the factory airbox. Install the provided grommet into the hole on the aFe POWER tube then press in the plastic fitting. Make sure to clock the fitting with the tab facing toward the small end of the tube, as shown in Figure G.

Step 18: Secure the temperature sensor into the plastic fitting by turning clockwise.

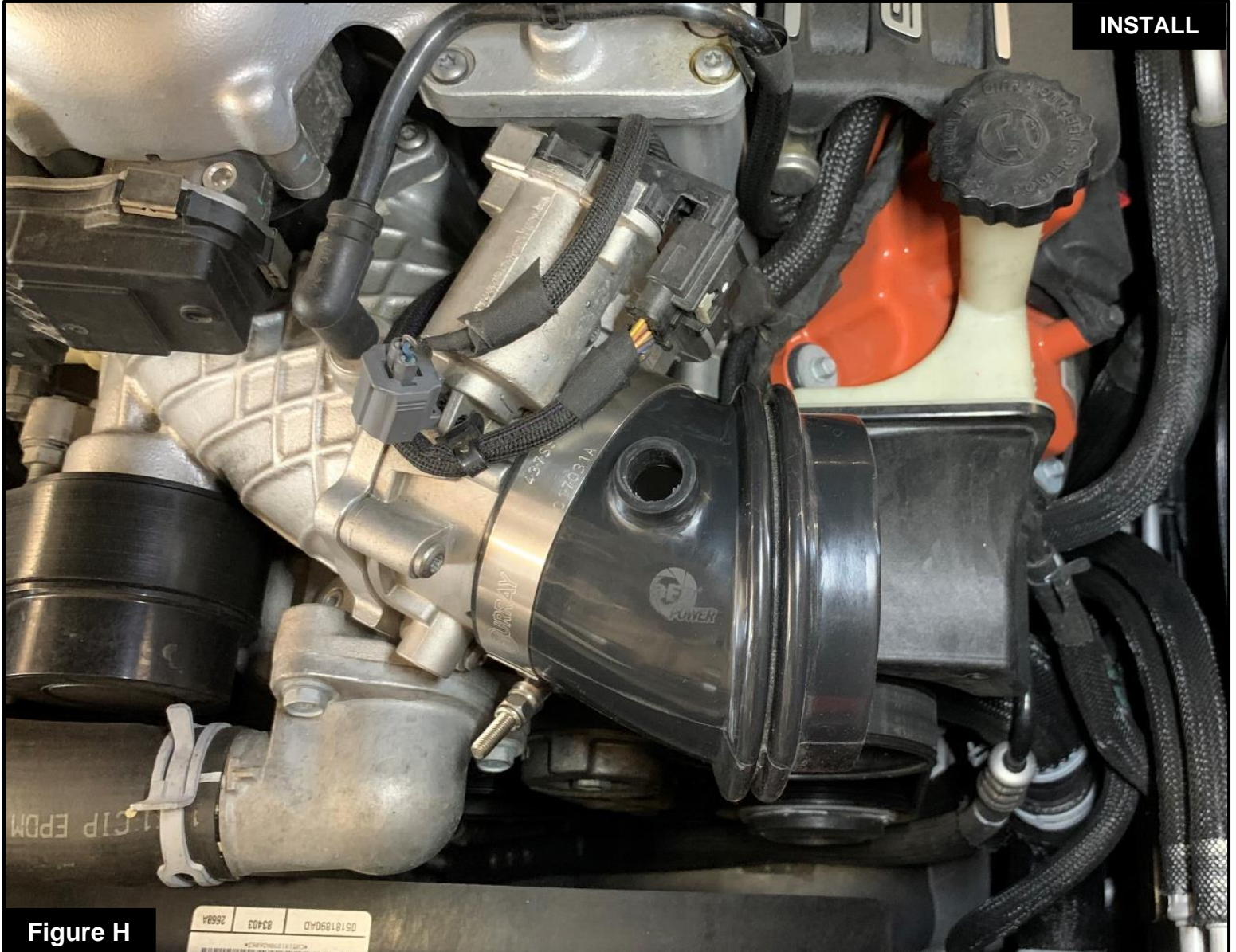

Refer to Figure H for Step 19:

Step 19: Install the coupling on the throttle body. Install the clamp closest to the throttle body only, do not tighten clamp yet.

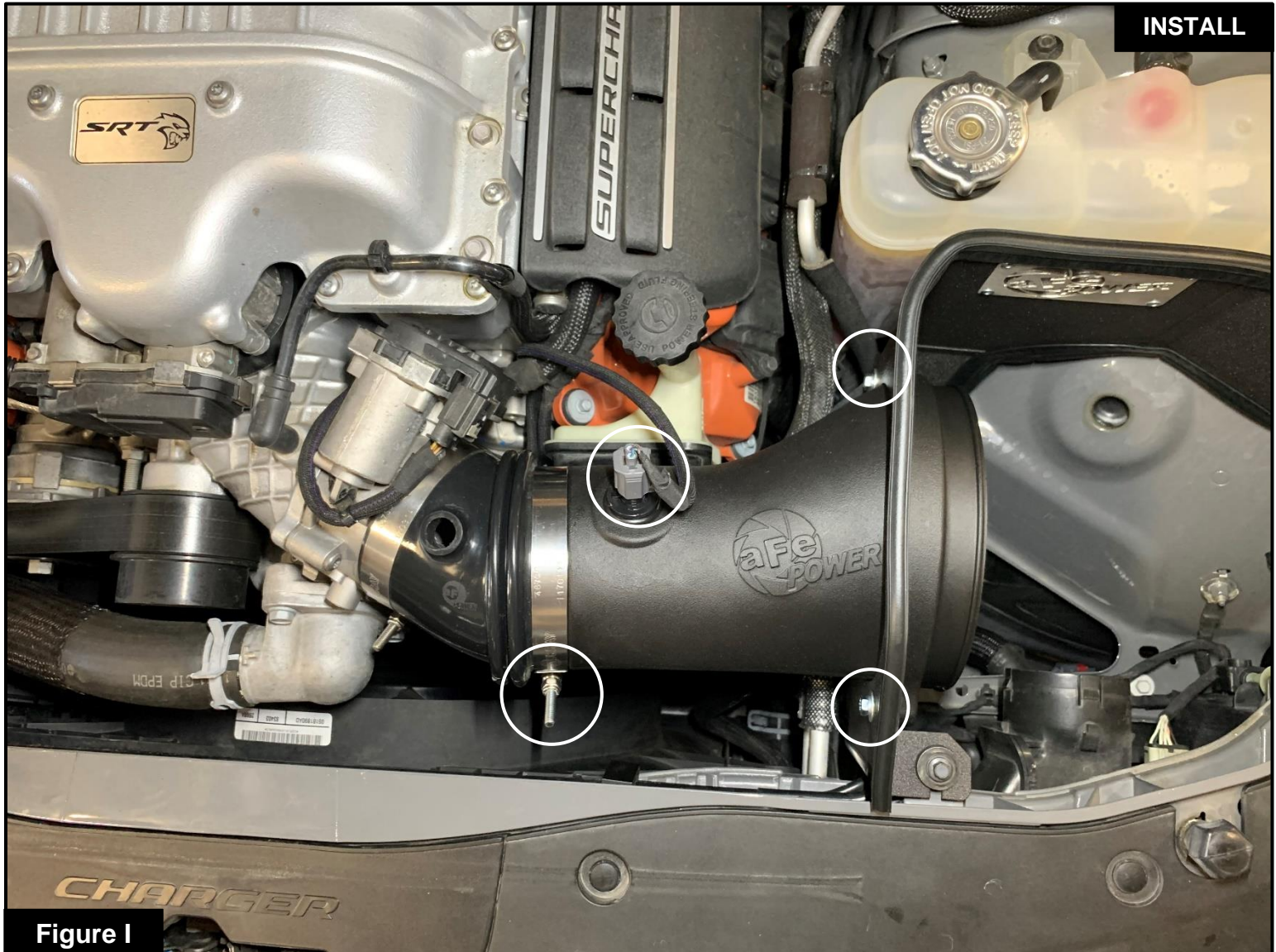

Figure I

Refer to Figure I for Steps 20-24:

Step 20: Install the aFe POWER intake tube, by sliding the tube through the housing then into the coupling.

Step 21: Open the remaining T-bolt clamp and install it over the coupling and tube end.

Step 22: Secure the aFe POWER tube to the aFe POWER housing using the furnished M6 screws, lock washers, and flat washer.

Step 23: Make sure the coupling, tube and air filter are aligned correctly, then tighten all clamps.

Step 24: Reconnect the temperature sensor harness.



Refer to Figure J for Steps 25-26:

Step 25: (**For 17-18 models ONLY**) Remove the elbow fitting from the factory tube and press it into the aFe POWER coupling.

Step 26: (**For 17-18 models ONLY**) Reconnect the elbow fitting to the factory hose.

INSTALL

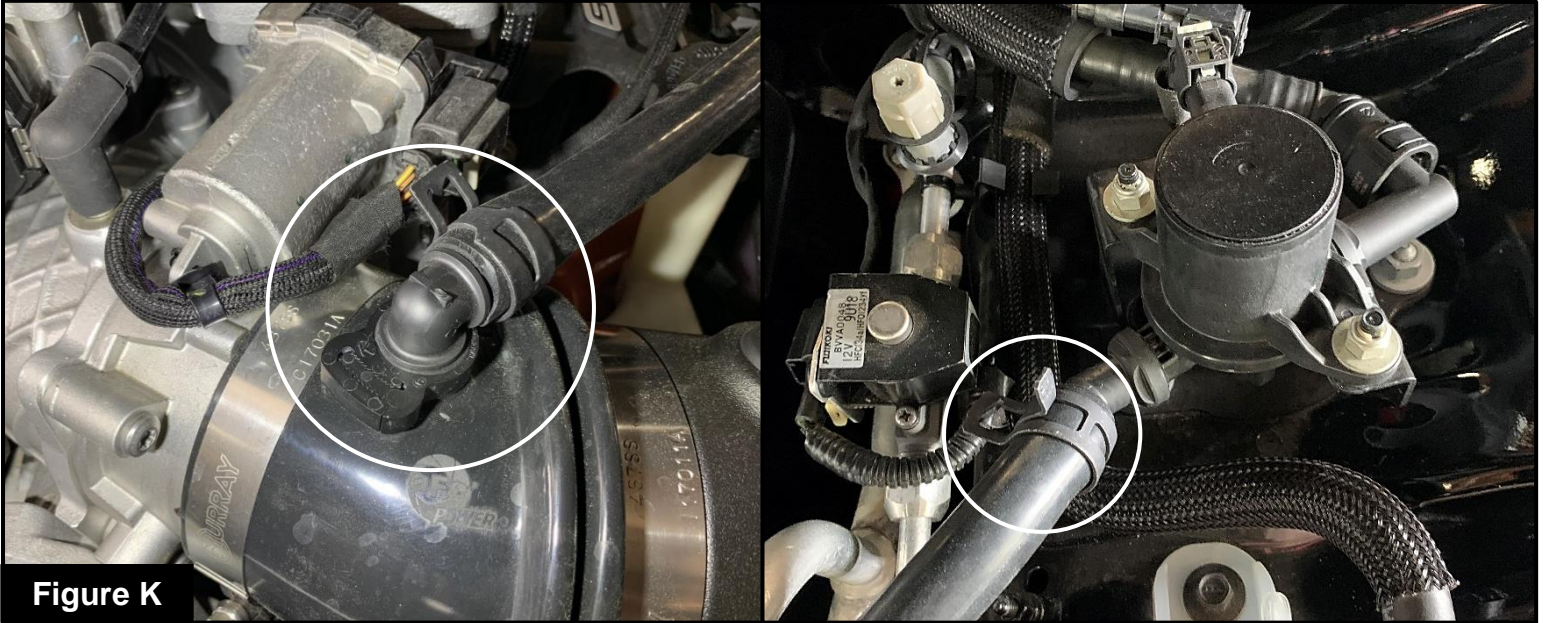

Figure K

Refer to Figure K for Steps 27-28:

Step 27: (For 19-20 Models ONLY) Install the two spring clamps over the provided silicone hose (deep enough on the hose so you can still install a fitting into the hose). Press the 90 Degree elbow fitting into one end of the hose.

Step 28: (For 19-20 Models ONLY) Place the Snap-Grip Clamp over the hole onto the coupling mounted to the throttle body, then press in the 90 Degree elbow fitting into it. Connect the other end of the silicone hose to the MUA system. Move the spring clamps on the hose to secure the hose connections and close the Snap-Grip clamp using pliers to secure the 90 Degree fitting into the coupling.

**Figure L****Refer to Figure L for Steps 29-30:**

Step 29: Install the filter onto the tube and tighten the clamp. **Pre-filter and rain shield are available and sold separately to protect the filter from water passing through the hood opening.**

Step 30: Verify all connections are secured. Your installation is now complete. Thank you for choosing aFe POWER!

NOTE: Check all screws, clamps, and connectors are secure after 100-200 miles.



Pro DRY S Air Filter



P/N: 21-91068

Pro 5R Air Filter



P/N: 24-91068

Pro GUARD 7 Air Filter



P/N: 72-91068

Pre-Filter



P/N: 28-10243

Blue Squeeze Restore Kit



P/N: 90-50501

PRO DRY S Restore Kit



P/N: 90-59999

Sprint Booster Challenger



P/N: 77-12002

Sprint Booster Charger



P/N: 77-12009

Rain Shield Black



P/N: 54-12808-B

Rain Shield Carbon Fiber Finish



P/N: 54-12808-C