

**advanced FLOW engineering** Quantum Cold Air Intake System

**Instruction Manual** P/N: 53-10019D / 53-10019R

Make: Jeep Model: Wrangler (JL) Year: 2018-2020 Engine: L4-2.0L (t)



- Please read the entire instruction manual before proceeding.
- Ensure all components listed are present.
- If you are missing any of the components, call customer support.
- Ensure you have all necessary tools before proceeding.
- Do not attempt to work on your vehicle when the engine is hot.
- Disconnect the negative battery terminal before proceeding.
- Retain factory parts for future use.

Label	Qty.	Description	Part Number
A1	1	Air Filter (Pro DRY S)	21-90105
A2	1	Air Filter (Pro 5R)	23-91133
B	1	Tube	05-5310019B1
C	1	Housing	05-5310017B2
D	1	Coupling, Silicone Bellow Reducer: (5"x4.5")ID x 3.25"L	05-01457
E	1	Coupling, Silicone Bellow: 3.25"ID x 3"L	05-01480
F	2	Clamp, #048	03-50007
G	1	Clamp, #072	03-50010
H	1	Clamp, #080	03-50011
I	1	Grommet, Rubber	03-50167
J	1	Fitting, Air Temp Sensor	05-01454
K	1	Brass Nipple, 3/8" OD	03-50193
L	1	Silicone Hose, 3/8" ID x 13" Long	05-01503
M	1	Fitting, CCV Vacuum Generator	05-01499
N	1	Retainer Clip, 1/4" Hole	05-01350

**Installation will require the following tools:**

8mm nut driver or flat-head screwdriver, 10mm socket and driver, panel popper tool, 9/16" wrench or adjustable wrench, and needle nose pliers.

**Emissions Disclaimer:** This product is not currently CARB exempt and is not available for purchase in California or for use on any vehicle registered with the California Department of Motor Vehicles.

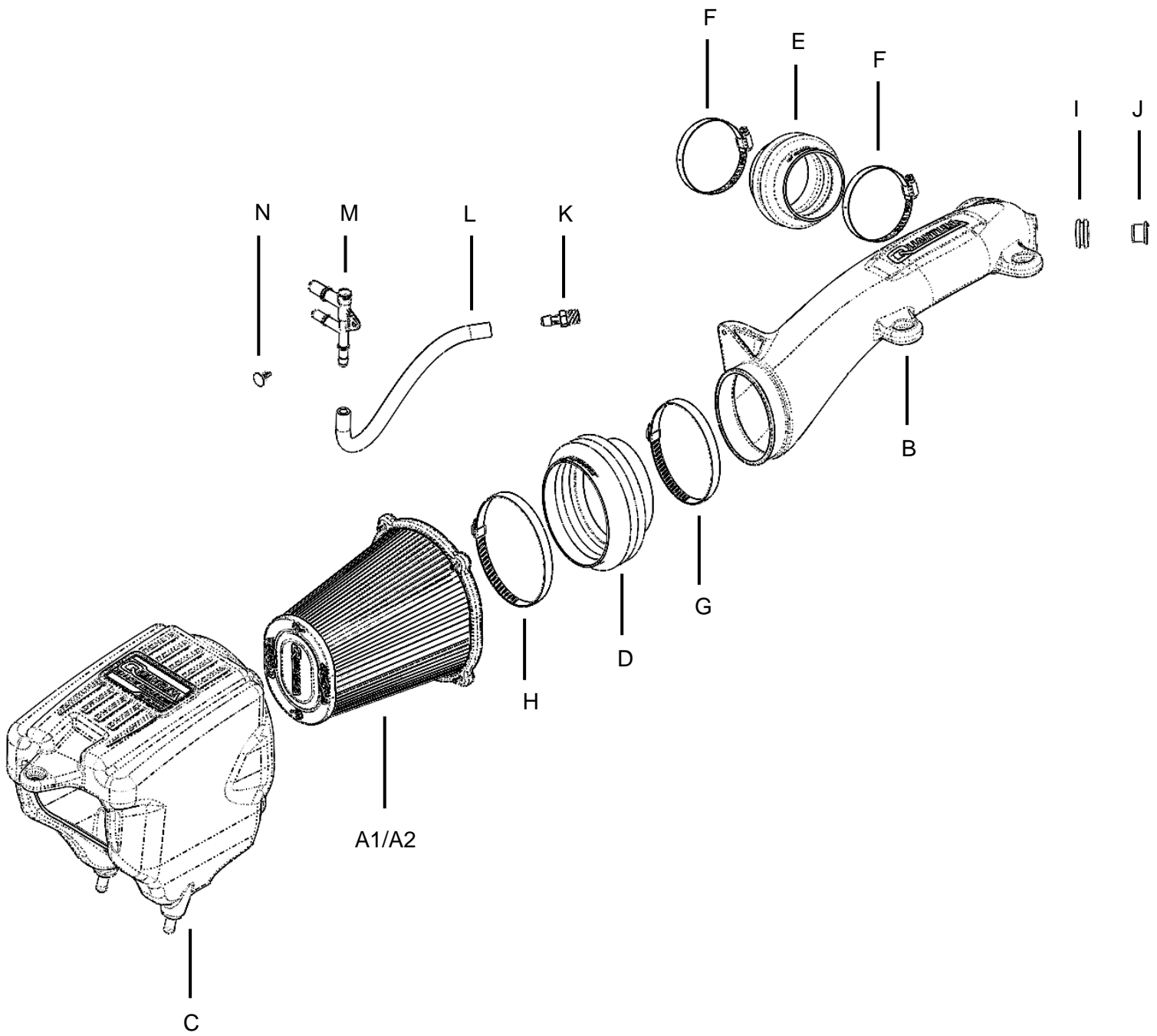



Figure A

## Refer to Figure A for Steps 1-2

Step 1: Using a 10mm socket and driver, remove the (3) screws (1) securing the OE intake to the vehicle.

Step 2: Using an 8mm nut driver, loosen the two clamps (2) on the intake tube.



Figure B

### **Refer to Figure B for Steps 3-5**

Step 3: Disconnect the two vent lines that are connected to the vacuum generator ③ by pushing on the grey clips and sliding the tubes off the fittings.

Step 4: Disconnect the Intake Air Temperature (IAT) sensor ④.

Step 5: Remove the attaching clip for the IAT sensor harness ⑤ and move the harness out of the way for now.

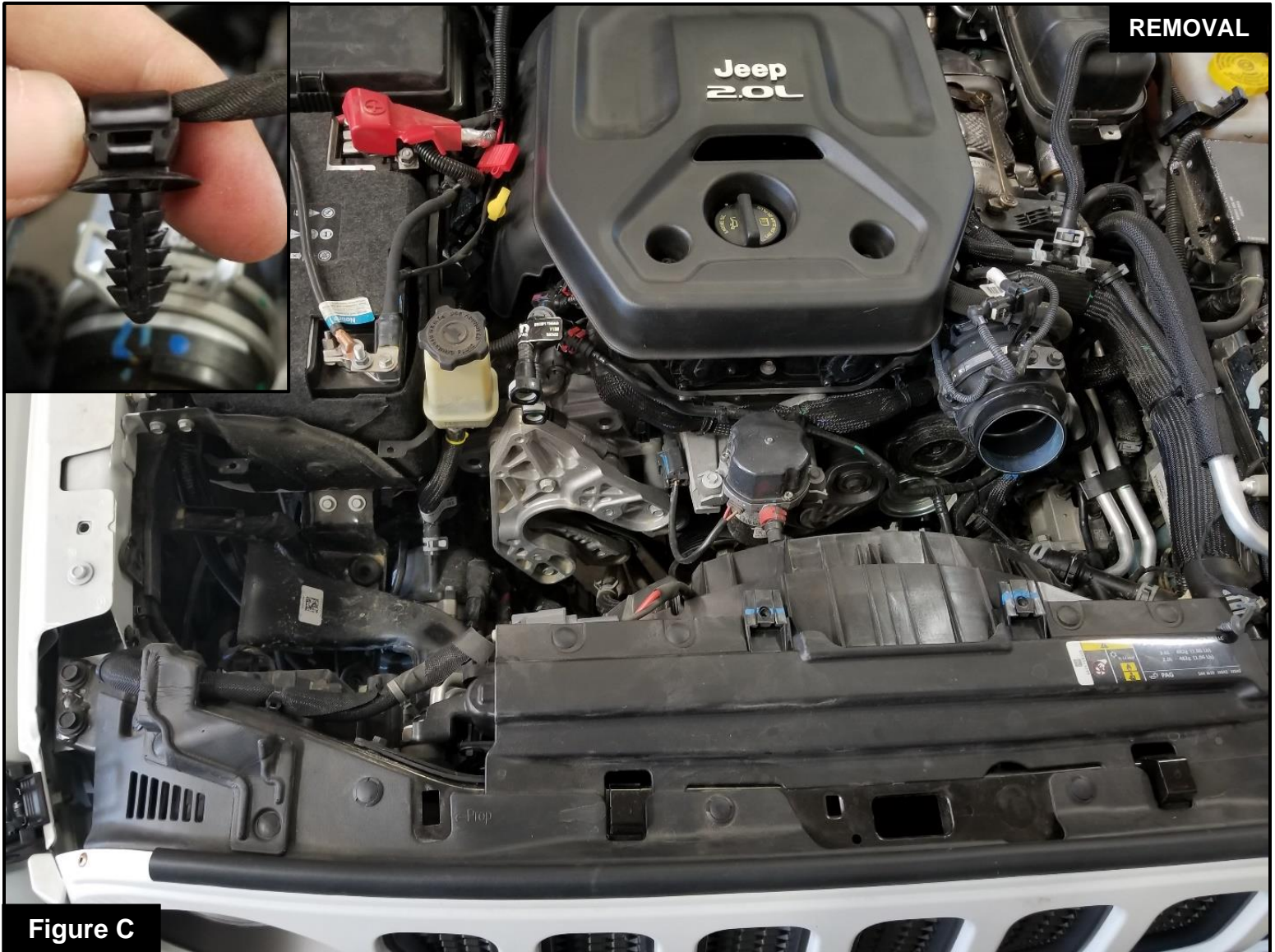

**Figure C**

### **Refer to Figure C for Steps 6-8**

Step 6: Remove the OE intake tube from the vehicle.

Step 7: Remove the OE housing from the vehicle by lifting straight upward. If the rubber grommets pop off with the housing, then remove them from the housing and place them back into the holes in the mounting bracket.

Step 8: If the attaching clip on the IAT sensor harness is bent out of shape, then repair it so that it looks like the clip shown in the small photo.

**Figure D****Refer to Figure D for Steps 9-10**

Step 9: Remove the metal sleeves and rubber grommets ⑥ from the OE intake tube and reinstall them into the aFe intake tube as shown.

Step 10: Using a 9/16" wrench or adjustable wrench, install the supplied brass barbed fitting ⑦ into the aFe intake tube.

**Figure E****Refer to Figure E for Step 11**

Step 11: Attach the new silicone hose to the barbed fitting and the plastic CCV fitting (8) as shown. Secure the CCV fitting with the provided push clip (9).



**Figure F**

### **Refer to Figure F for Steps 12-14**

Step 12: Install the grommet and temp sensor adaptor (10) into the hole on the front of the intake tube.

Make sure that the bead on the adaptor is positioned correctly in the grommet so that it cannot pop out during use.

Step 13: Carefully remove the IAT sensor (11) from the OE intake tube by lifting it up slightly on the plastic tab and rotating the sensor 1/4 turn counterclockwise.

Step 14: Reinstall the IAT sensor into the temp sensor adaptor on the aFe intake tube and make sure to lock it into position by rotating it clockwise until the small tab clicks into place.



**Figure G**

**Refer to Figure G for Steps 15-17**

- Step 15: Remove the metal sleeve and rubber grommet (12) from the OE intake housing and reinstall them into the aFe intake housing as shown.
- Step 16: Slide the filter into the aFe housing and secure it in place by tightening all four screws.
- Step 17: Install the aFe housing and filter assembly into the vehicle by lining up the pegs into the grommets and then pressing down firmly to lock them into place. Use one of the screws removed in Step 1 to secure the housing to the fender.



Figure H

### Refer to Figure H for Step 18

Step 18: Install the smaller silicone coupler (13) and two clamps over the turbo inlet adaptor and place the larger silicone coupler (14) with its two clamps over the filter flange prior to installing the tube into the vehicle.



Figure I

**Refer to Figure I for Steps 19-21**

Step 19: Insert the tube into the coupler near the filter and then rotate the other end of the tube so that it slides into the coupler near the turbo inlet adaptor.

Step 20: Reconnect the IAT sensor harness to the IAT sensor (15) and secure the push clip on the harness into the hole on the tube.

Step 21: Using the remaining (2) screws (16) removed in Step 1, secure the intake tube to the core support.

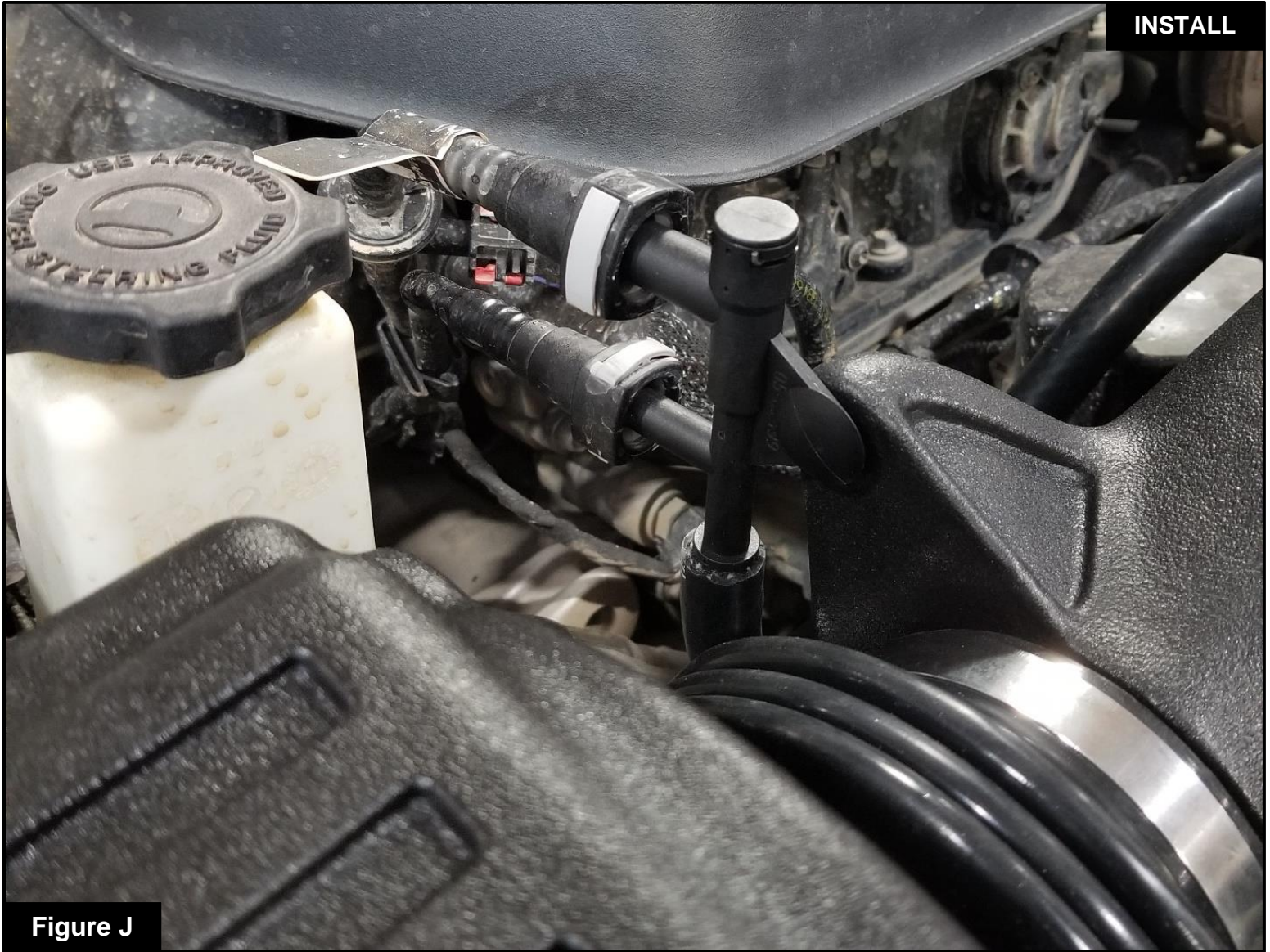
**Figure J****Refer to Figure J for Step 22**

Step 22: Push the connectors all the way onto the fitting until they both lock into place.



Figure K

### **Refer to Figure K for Steps 23-24**

Step 23: Tighten all (3) clamps using an 8mm nut driver or flathead screwdriver. Do not over tighten the clamps.

Step 24: Verify that all connectors are secure and the (3) screws are tightened properly.



Pro DRY S Air Filter



P/N: 21-90105

Pro 5R Air Filter



P/N: 23-91133

Pro-GUARD 7 Air Filter



P/N: 72-91133

Pre-Filter



P/N: 28-10423

Pro DRY S Restore Kit



P/N: 90-59999

Blue Squeeze Restore Kit



P/N: 90-50501

Gold Squeeze Restore Kit



P/N: 90-50500

SPRINT BOOSTER V3



P/N: 77-16205

Front Differential Cover



P/N: 48-36211-YC

Scorpion Grille w/LEDs

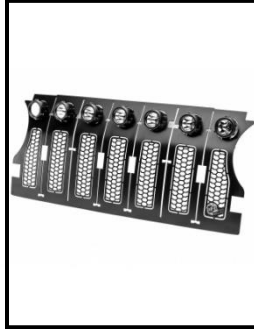

P/N: 79-21004L

Cat-Back Exhaust System



P/N: 49-48053

Axle-Back Exhaust System



P/N: 49-48067-P