

advanced FLOW engineering Quantum Air Intake

Instruction Manual P/N: 53-10013D / 53-10013R

Make: **Dodge** Model: **RAM 1500** Year: **2003-2008** Engine: **V8-5.7L HEMI**



- Please read the entire instruction manual before proceeding.
- Ensure all components listed are present.
- Ensure you have all necessary tools before proceeding.
- Do not attempt to work on your vehicle when the engine is hot.



Retain factory parts for future use.

Label	Qty.	Description	Part Number
A1	1	Air Filter (Pro DRY S)	21-90103
A2	1	Air Filter (Pro 5R)	23-91132
B	1	Tube	05-5310013B1
C	1	Housing	05-5310009B2
D	1	Coupling, Silicone Bellow	05-01457
E	1	Coupling, Silicone Hump	05-01264
F	1	Grommet, Rubber	03-50167
G	1	Fitting, Air Temp Sensor	05-01454
H	1	Clamp, #080	03-50011
I	1	Clamp, #072	03-50010
J	2	Clamp, #052	03-50008
K	1	Hose, Breather: 5/8"	05-01208

Installation will require the following tool(s):

8mm nut driver, Phillips #3 screwdriver, 10mm socket and driver with extension, and hose cutting shears.

Emissions Disclaimer: This product is not currently CARB exempt and is not available for purchase in California or for use on any vehicle registered with the California Department of Motor Vehicles.

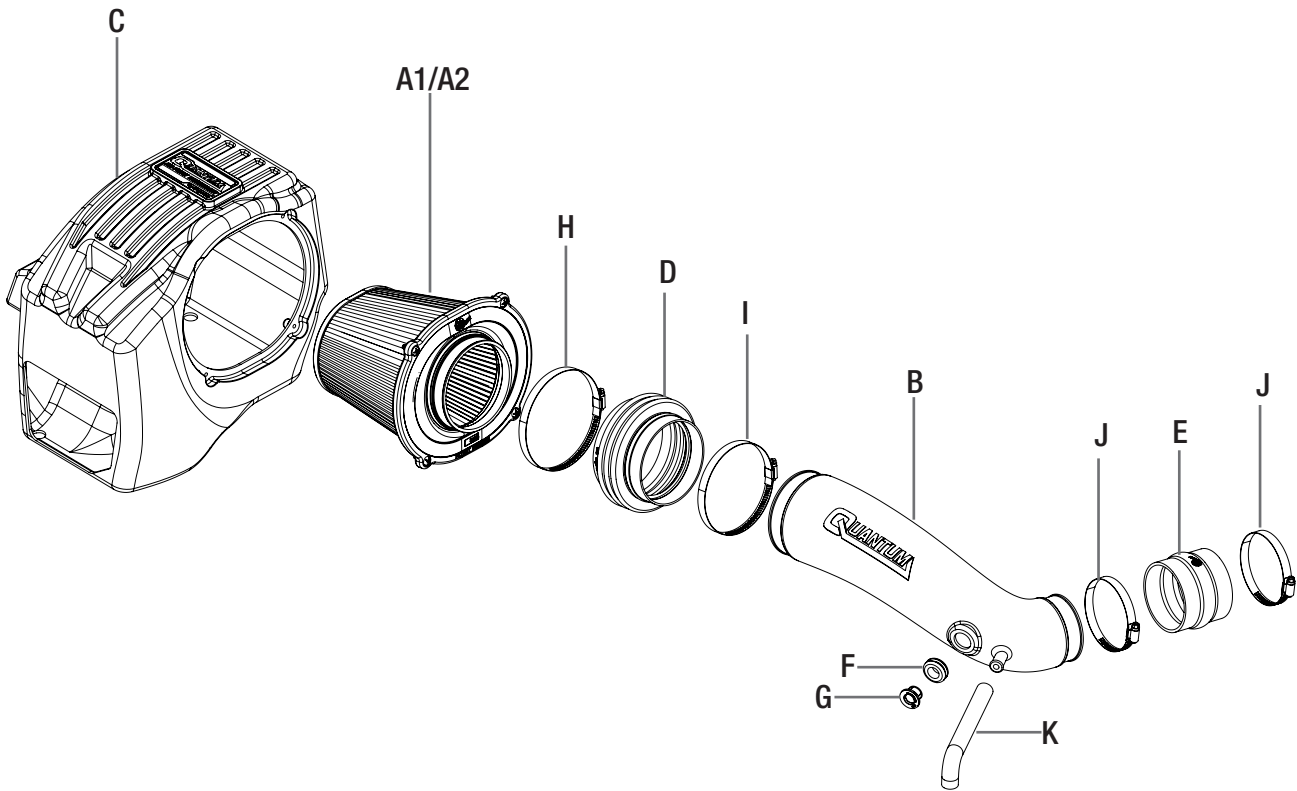

**Figure A****Refer to Figure A for Steps 1-2**

Step 1: Using an 8mm nut driver, loosen the clamp (1) on the factory intake tube at the filter housing.

Step 2: Disconnect the CCV (2) line from the factory filter housing.



Figure B

Refer to Figure B for Step 3

Step 3: Remove the factory filter housing by pulling the intake tube away from the housing, then pull the housing straight up off the mounting pegs. Set aside.



Figure C

Refer to Figure C for Step 4

Step 4: Remove the CCV line (3) from the vehicle by disconnecting from the vent port next to the oil fill neck.

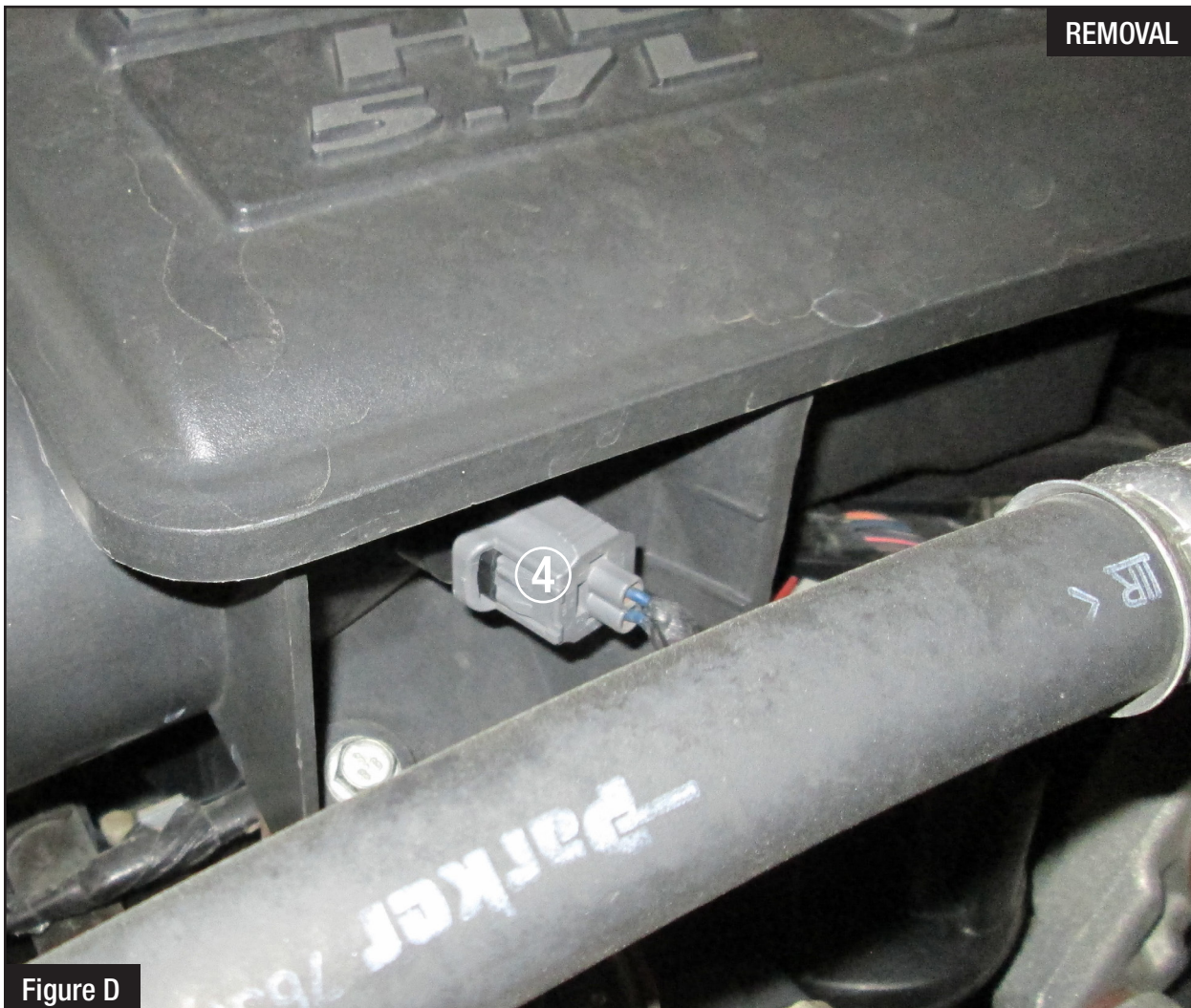

Figure D

Refer to Figure D for Step 5

Step 5: Disconnect the temperature sensor wire harness (4) from the sensor on the factory intake plenum.

**Figure E****Refer to Figure E for Step 6**

Step 6: Using a 10mm socket and extension, loosen the two screws (5) securing the intake plenum. Remove the intake plenum and tube from the vehicle, ensuring that the plenum coupler is also removed from the throttle body.



Figure F



INSTALL

Refer to Figure F for Step 7

Step 7: Transfer the four (4x) rubber grommets (6) from the factory filter housing to your aFe POWER airbox as shown.

**Figure G****Refer to Figure G for Step 8**

Step 8: Install your aFe POWER airbox into the vehicle by lining up the four (4x) mounting grommets with the mounting pegs and pressing down firmly to fully seat the airbox.



Refer to Figure H for Steps 9-11

- Step 9: Install your aFe POWER air filter (7) into the airbox using a #3 philips screwdriver to tighten all four (4x) mounting screws.
- Step 10: Install the supplied bellow coupler (8) onto the air filter using the supplied #080 clamp (9) and tighten using an 8mm nut driver.
- Step 11: Place the supplied #072 clamp (10) onto the open end of the bellow coupler at the filter leaving the clamp loose.



Figure 1

Refer to Figure 1 for Step 12

Step 12: Install the provided rubber grommet and sensor fitting (11) into the aFe POWER intake tube as shown.

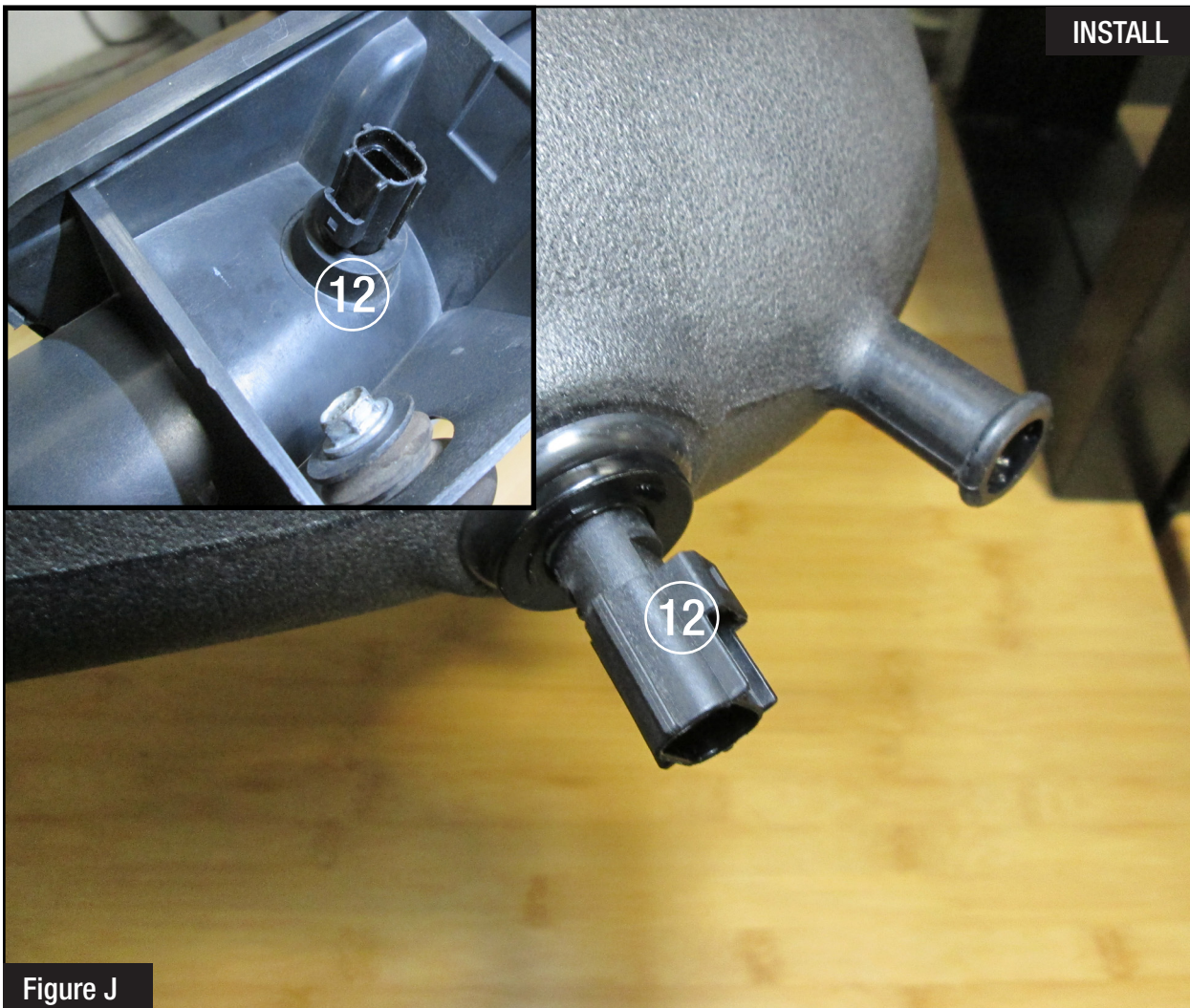

Figure J

Refer to Figure J for Steps 13-14

Step 13: Remove the temperature sensor (12) from the factory intake plenum by rotating a quarter turn counter-clockwise and gently pulling outward.

Step 14: Install the temperature sensor (12) into the aFe POWER intake tube by inserting into the sensor fitting and rotating a quarter turn clockwise to secure it in place.

Figure K

Refer to Figure K for Steps 15-16

Step 15: Install the supplied aFe POWER straight coupler (13) onto the throttle body using one of the #052 clamps (14). Tighten using an 8mm nut driver.

Step 16: Install the remaining #052 clamp (14) onto the aFe POWER coupler on the throttle body, but do not tighten at this time.



Figure L

Refer to Figure L for Step 17

Step 17: Install the aFe POWER intake tube first into the bellow coupler at the filter, then into the coupler at the throttle body. Tighten both clamps using an 8mm nut driver.



Figure M

Refer to Figure M for Step 18

Step 18: Using a pair of hose cutting shears, trim approximately 8 inches off the aFe POWER silicone hose provided, leaving the 90-degree bend.



Figure N

Refer to Figure N for Step 19

Step 19: Install the trimmed silicone hose with the 90-degree bend on the port by the oil fill neck (15).
Connect the open end to the port on your aFe POWER intake tube.



Figure 0

Refer to Figure 0 for Step 20

Step 20: Reconnect the temperature sensor harness (16).



Figure P

Refer to Figure P for Step 21

Step 21: Check that all components are tight and secure. Your installation is now complete. Thank you for choosing aFe POWER!

NOTE: Check all bolts, clamps, and connectors after 100-200 miles.



PRO DRY S Air Filter



P/N: 21-90103

PRO 5R Air Filter



P/N: 23-91132

PRO DRY S Restore Kit



P/N: 90-50001

Blue Squeeze Restore Kit



P/N: 90-50501

Throttle Body Spacer



P/N: 46-32002

Cat-Back Exhaust



P/N: 49-42008-1 (Pol. Tips)

Sprint Booster V3



P/N: 77-12005

SCORCHER PRO Tune



P/N: 77-32001