

advanced FLOW engineering Quantum Air Intake

Instruction Manual P/N: 53-10009D / 53-10009R

Make: **Dodge/RAM** Model: **1500** Year: **2009-2018** Engine: **V8-5.7L HEMI**



- Please read the entire instruction manual before proceeding.
- Ensure all components listed are present.
- If you are missing any of the components, call customer support.
- Ensure you have all necessary tools before proceeding.
- Do not attempt to work on your vehicle when the engine is hot.

Retain factory parts for future use.

Label	Qty.	Description	Part Number
A1	1	Air Filter (Pro DRY S)	21-90103
A2	1	Air Filter (Pro 5R)	23-91132
B	1	Tube	05-5010009B1
C	1	Housing	05-5010009B2
D	1	Scoop	05-5010009B3
E	1	Coupling, Silicone Bellow	05-01457
F	1	Coupling, Silicone Straight	05-01264
G	1	Grommet, Rubber	03-50167
H	1	Fitting, Air Temp Sensor	05-01454
I	1	Clamp, #072	03-50010
J	1	Clamp, #080	03-50011
K	2	Clamp, #052	03-50008
L	1	Hose, Fuel: 5/8" (2 inches)	05-00069
M	1	Hose, Fuel: 5/8" (24 inches)	05-00069
N	2	Fitting, Elbow: 5/8"	03-50165

Installation will require the following tool(s):

8mm nut driver and Phillips #3 screwdriver.

Note: Legal in California for use on race vehicles only. The use of this device on vehicles used on public streets or highways is strictly prohibited in California and others states that have adopted California emission regulations.

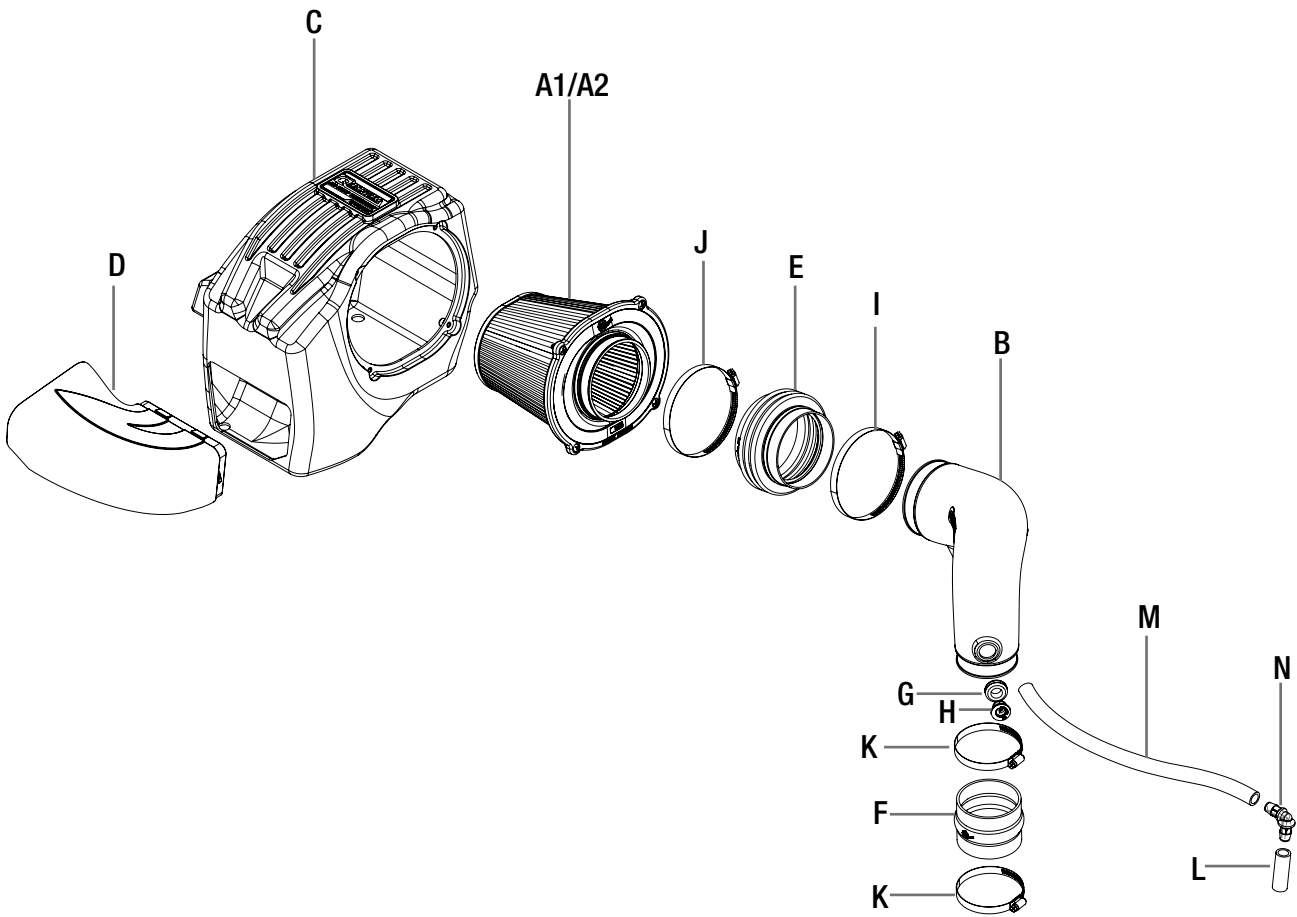



Figure A

Refer to Figure A for Steps 1-4.

- Step 1: Disconnect the temperature sensor harness (1) from the sensor on the stock intake tube.
- Step 2: Loosen the stock clamps (2) at the throttle body and housing using an 8mm nut driver.
- Step 3: Remove the stock intake tube (3) by pulling up from the throttle body then away from the stock housing. Set aside.
- Step 4: Remove the engine cover (4) by gently lifting up on the front until it disconnects from the mounting grommets, then towards the front of the vehicle.



Figure B

Refer to Figure B for Steps 5-6.

Step 5: Remove the stock vent line (5) by pulling away from the stock housing then lifting away from the valve cover behind the oil fill neck.

Step 6: Remove the stock airbox and scoop (6) by pulling straight up off the mounting pegs, and rotating towards the front of the vehicle to clear the A/C lines.



Figure C

Refer to Figure C for Step 7

Step 7: Transfer all four rubber grommets ⑦ from the stock airbox to the aFe POWER airbox as shown.



Figure D

Refer to Figure D for Steps 8-10.

- Step 8: Install the provided rubber grommet and sensor fitting (8) into the aFe intake tube as shown.
- Step 9: Remove the temperature sensor (9) from the stock intake tube by rotating a quarter turn and gently pulling outward.
- Step 10: Install the temperature sensor into the aFe intake tube by inserting into the sensor fitting and rotating a quarter turn until it locks into place.

**Figure E****Refer to Figure E for Steps 11-13.**

- Step 11: Install the aFe POWER air scoop (10) into the aFe power airbox by inserting it into the opening and gently pressing until both top and bottom lock into place.
- Step 12: Slide the aFe filter into the aFe airbox. Install the aFe filter using a #3 Philips screwdriver to tighten all four mounting screws.
- Step 13: Install the supplied bellow coupler (11) onto the air filter using the supplied #80 clamp (12) and tighten using an 8mm nut driver.



Figure F

Refer to Figure F for Step 14.

Step 14: Install the aFe POWER airbox assembly into the vehicle by pointing the scoop downward and rotating into place as shown. Slip the grommets over all four mounting pegs and press firmly down to fully seat the housing.

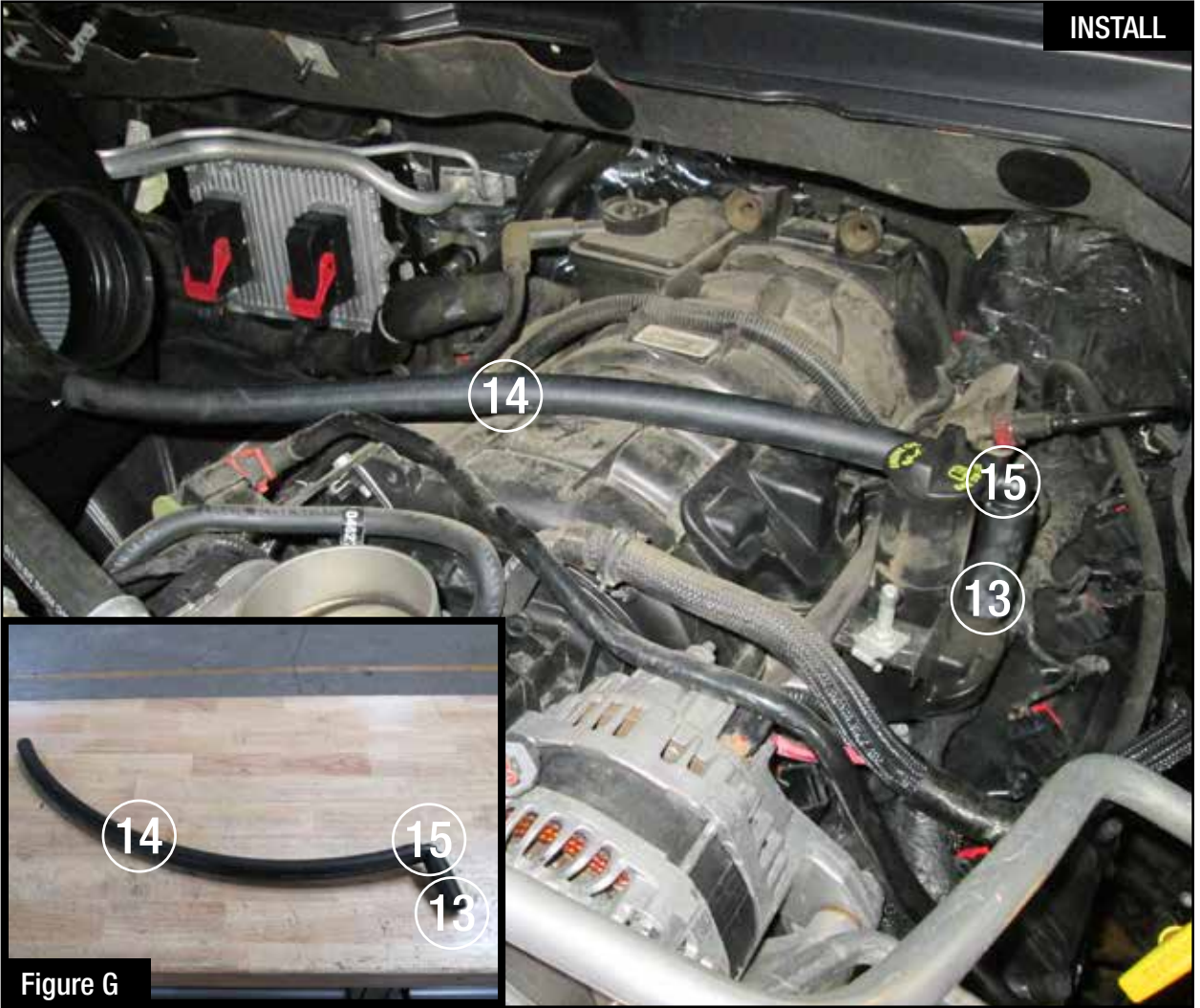

Refer to Figure G for Steps 15-16.

Step 15: Connect both the 2" (13) and 24" (14) lengths of fuel hose to the 90 degree fitting (15) as shown.

Step 16: Install the hose assembly with the 2" side onto the engine vent fitting behind the oil fill neck and the 24" length towards the aFe airbox.



Figure H

Refer to Figure H for Step 17.

Step 17: Install the aFe coupler (16) onto the throttle body using one of the supplied #52 clamps (17). Tighten the clamp using an 8mm nut driver.



Figure 1

Refer to Figure 1 for Step 18.

Step 18: Reinstall the engine cover while ensuring that the vent hose is accessible through the opening on the side of the engine cover as shown.



Figure J

Refer to Figure J for Steps 19-20.

Step 19: Install the remaining #52 clamp (18) onto the top of the coupler at the throttle body. Do not tighten.

Step 20: Install the #72 clamp (19) onto the coupler at the filter. Do not tighten.

**Figure K****Refer to Figure K for Steps 21-22.**

Step 21: Install the aFe POWER intake tube first into the coupler at the filter (20), then into the coupler at the throttle body (21). Tighten both clamps using an 8mm nut driver.

Step 22: Connect the vent hose (22) to the aFe POWER intake tube by reaching under the engine cover and pressing it firmly onto the vent port on the intake tube.



Figure L

Refer to Figure L for Steps 23-24.

Step 23: Reconnect the temperature sensor harness.

Step 24: Check that all components are tight and secure. Your installation is now complete.

NOTE: Check all bolts, clamps, and connectors after 100-200 miles.



PRO DRY S Air Filter



P/N: 21-90103

PRO 5R Air Filter



P/N: 23-91132

Pro DRY S Restore Kit



P/N: 90-50001

Blue Squeeze Restore Kit



P/N: 90-50501

Shorty Headers



P/N: 48-42001-1

Y-Pipe Exhaust

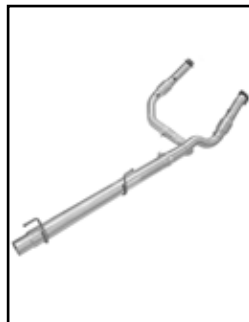

P/N: 48-42003 (Street)
48-42004 (Race)

Cat-Back Exhaust



P/N: 49-42013-B (Black Tips)
49-42013-P (Polished Tips)

Rear Differential Cover



P/N: 46-70272-WL (w/ Oil)
46-70272 (Black)
46-70270 (Raw)

Throttle Body Spacer



P/N: 46-32005

Sprint Booster V3



P/N: 77-12007