

advanced FLOW engineering

Instruction Manual P/N: 53-10008D / 53-10008R

Make: **Ford** Model: **F-150 EcoBoost** Year: **2015-2019** Engine: **V6-2.7L (tt)/3.5L (tt)**
Make: **Ford** Model: **F-150 Raptor** Year: **2017-2019** Engine: **V6-3.5L (tt)**



- Please read the entire instruction manual before proceeding.
- Ensure all components listed are present.
- Ensure you have all necessary tools before proceeding.
- Do not attempt to work on your vehicle when the engine is hot.

Retain factory parts for future use.

Label	Qty.	Description	Part Number
A1	1	Air Filter (Pro DRY S)	21-90105
A2	1	Air Filter (Pro 5R)	23-91133
B	1	Tube	05-53112B1
C	1	Housing	05-53112B2
D	1	Coupling, Silicone Below	05-01456
E	1	Coupling, Silicone Reducer	05-01331
F	1	Coupling, Silicone Hump	05-01399
G	1	Plug	05-00937
H	1	Fitting, Air Temp Sensor	05-01454
I	1	Grommet	03-50167
J	1	Screw, Hex Hd: M6	03-50052
K	1	Washer: M6	03-50070
L	1	Clamp, #052	03-50008
M	2	Clamp, #064	03-50006
N	1	Clamp, #044	03-50019
O	2	Clamp, #080	03-50011
P	1	Harness, IAT	05-70023
Q	1	Insert, Vent	05-01405
R	2	Ties, Nylon Cable 12"	05-60167

Installation will require the following tool(s):

8mm, 13mm nut driver or socket and extension, Flat screwdriver #2 Phillips screwdriver, pliers.

Note: Legal in California for use on race vehicles only. The use of this device on vehicles used on public streets or highways is strictly prohibited in California and others states that have adopted California emission regulations.

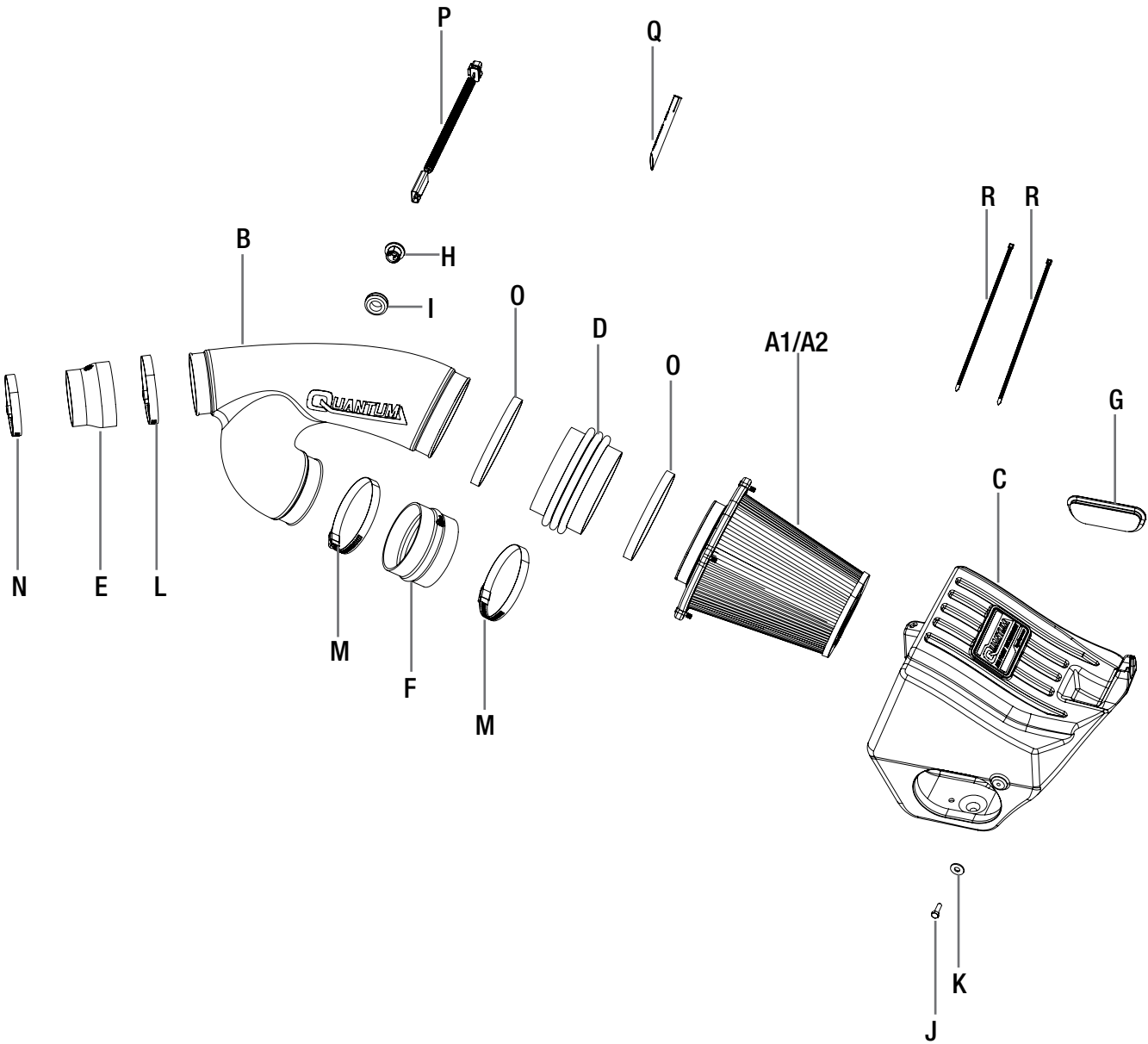



Figure A

Refer to Figure A for Steps 1-3.

- Installation pictures are from a 2017 F-150 V6-3.5L (tt), other years and model vehicles may vary slightly.
- Step 1: Disconnect the temperature sensor from the back side of the factory intake tube and remove the wire harness clips from the factory airbox.
 - Step 2: Loosen the two clamps connecting the factory intake tubes to the turbo inlet tubes, then disconnect those tubes.
 - Step 3: Unclip the top of the factory air box then remove the tube and top of the air box as one piece out of the vehicle.



Refer to Figure B for Steps 4-6.

- Step 4: Detach the wastegate actuator from the factory housing if the vehicle is equipped with one.
- Step 5: With a 13mm socket, remove the bolt securing the factory air box to the fender. This bolt will be reused.
- Step 6: Using a flat screwdriver, remove the two plastic rivets securing the inlet scoop to the front end. Then take off the factory air box and inlet scoop as one piece out of the vehicle.

Vent insert installation:

REMOVAL



Refer to Figure C for Step 7.

(These procedures should be done with the inlet tubes installed on the engine. It is shown off the vehicle for better illustration.)

Step 7: Locate the factory plastic tube feeding the driver's side turbo inlet.

**Figure D****Refer to Figure D for Step 8.**

Step 8: Locate the valve cover vent tube that feeds into driver's side turbo inlet. It is not necessary to remove the engine cover.

**Figure E****Refer to Figure E for Step 9.**

Step 9: Note the release clip on the vent tube connectors. Apply pressure against the exposed tail and pull vent fitting off of the turbo inlet tube. It is not necessary to disconnect at the valve cover end. There is a sensor and wire harness on this vent tube. Do not damage or remove these components.



Figure F

Refer to Figure F for Step 10.

Step 10: Insert vent fitting with slash cut facing turbo inlet. It should not be a loose fit. It is direction dependent and must not rotate once installed.



Refer to Figure G for Steps 11-12

Step 11: Reconnect the vent fitting. It will snap over without having to release the plastic clip. Pull up slightly to confirm installation.

Step 12: Installation of the vent insert is complete. If removal of the vent insert is required, it can be pulled out with internal snap ring pliers.



Figure H

Refer to Figure H for Steps 13-14.

Step 13: Remove the screw securing the factory air scoop to the factory housing. Then pull on the scoop to detach it from the housing.

Step 14: Push the factory air scoop in the Quantum housing and secure it with the provided M6 bolt and washer.

**Figure I****Refer to Figure I for Steps 15-16**

Step 15: If you have also purchased the aFe POWER scoop (P/N: 53-10008S) with your quantum intake, simply push it into the Quantum housing and secure it with the M6 bolt and washer provided with the scoop.

Step 16: Install the seal trim on the edge of the aFe POWER scoop.



Figure J

Refer to Figure J for Steps 17-20.

Step 17: Transfer the grommet and sleeve from the factory housing to the Quantum housing.

Step 18: Install the Quantum housing into the vehicle by pushing it into the factory grommet.

Step 19: Secure the housing to the fender using the factory bolt removed at Step 5.

Step 20: If the vehicle is equipped with one, mount the wastegate actuator onto the Quantum housing.



Figure K

Refer to Figure K for Step 21.

Step 21: Secure the factory scoop inlet with the factory plastic rivets. Or if you have the aFePower scoop, secure it with the provided plastic rivets.



Figure L

Refer to Figure L for Steps 22-23.

- Step 22: Slide the Quantum air filter into the housing. Secure it by tightening the four screws with a #2 Phillips screwdriver.
- Step 23: Install the supplied bellows coupling onto the filter opening. Install the supplied #80 clamps on the coupling but do not tighten at this time.



Figure M

Refer to Figure M for Steps 24-25.

Step 24: Install the reducer coupling onto the upper tube. Install the clamps on the coupling but do not tighten at this time.

Step 25: Install the hump coupling onto the lower turbo inlet tube. Install the clamps on the coupling but do not tighten at this time.



Figure N

Refer to Figure N for Steps 26-27.

Step 26: Install the provided grommet then the plastic fitting into the hole on the Quantum Tube.

Step 27: Transfer the air intake temperature sensor from the factory housing to the Quantum intake tube.

Rotate it counter clockwise to take it off the housing and turn it clockwise to lock it into the fitting on the Quantum tube.



Figure 0

Refer to Figure 0 for Steps 28-29.

Step 28: Install the Quantum tube into the couplings on the truck.

Step 29: Align the tube and couplings then tighten all clamps.



Figure P

Refer to Figure P for Step 30.

Step 30: Reconnect the temperature sensor to the wire harness of the truck. Depending on the model, if necessary use the extension harness provided. If using the extension harness, secure the harness with the provided zip ties.



Figure Q

Refer to Figure Q for Step 31.

Step 31: The kit includes an optional plug to close off the back auxiliary air inlet. Install the plug if you wish to close off the back auxiliary air inlet and only capture cold air from the front of the vehicle.

- Without the plug installed, the aFe Power intake will capture the maximum air available. More airflow offers more power. Yet some of this air is picked up from inside the engine compartment and could be warmer air. Warmer air will affect the performance of the vehicle.
- The plug installed on the housing will block off any hot engine air entering the housing and make sure the coolest air available is directed into the engine. It will also reduce the noise of the intake.

INSTALL



Figure R

Refer to Figure R for Step 32.

Step 32: Check all the components are tight and secure. Your Installation is now complete.

NOTE: Check all bolts, clamps, and connectors after 100-200 miles.