

advanced FLOW engineering Quantum Air Intake

Instruction Manual P/N: 53-10007D / 53-10007R

Make: **Chevrolet** Model: **Silverado HD** Year: **2017-2018** Engine: **V8-6.6L Duramax (L5P)**

Make: **GMC** Model: **Sierra HD** Year: **2017-2018** Engine: **V8-6.6L Duramax (L5P)**

Note: **Includes Denali Trim.**



- Please read the entire instruction manual before proceeding.
- Ensure all components listed are present.
- If you are missing any of the components.
- Ensure you have all necessary tools before proceeding.
- Do not attempt to work on your vehicle when the engine is hot.
- Disconnect the negative battery terminal before proceeding.
- Retain factory parts for future use.

Label	Qty.	Description	Part Number
A1	1	Air Filter (Pro DRY S)	21-90098
A2	1	Air Filter (Pro 5R)	23-91129
B	1	Tube	05-54008B1
C	1	Housing	05-54008B2
D	1	Clamp, #080	03-50011
E	1	Coupling, Silicone Bellow	05-01457
F	1	Clamp, #072	03-50010
G	1	Seal Trim 7/16" (26")	05-00072
H	2	Screws, Torx M4	03-50491
I	1	Plug	05-00850
J	1	Seal Trim 7/16" (21")	05-00072

Installation will require the following tools:

8mm Nut driver, T20 torx bit or driver, 13mm deep socket, extension and driver.

Note: Legal in California for use on race vehicles only. The use of this device on vehicles used on public streets or highways is strictly prohibited in California and others states that have adopted California emission regulations.

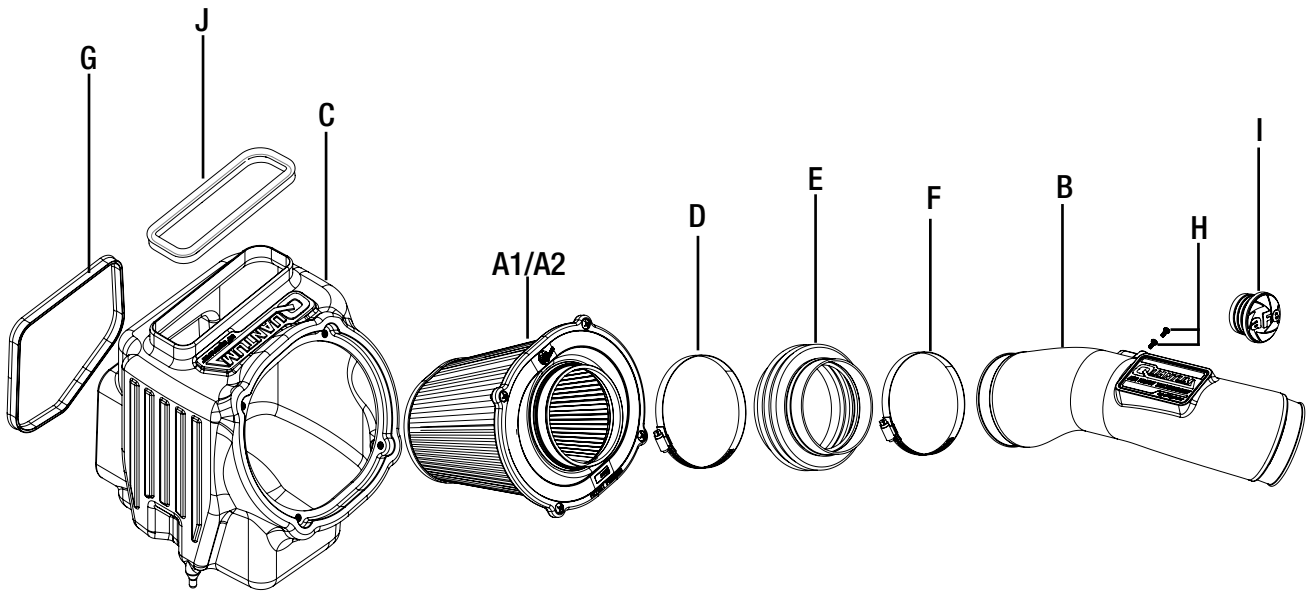



Refer to Figure A for Steps 1-2

Step 1: Disconnect the MAF sensor plug. ①

Step 2: Disconnect the MAF sensor harness clip ② from the OE airbox.

**Figure B****Refer to Figure B for Steps 3-4**

Step 3: Loosen the clamps (3) at the airbox and at the resonator coupler.

Step 4: Remove the stock intake tube. (4)

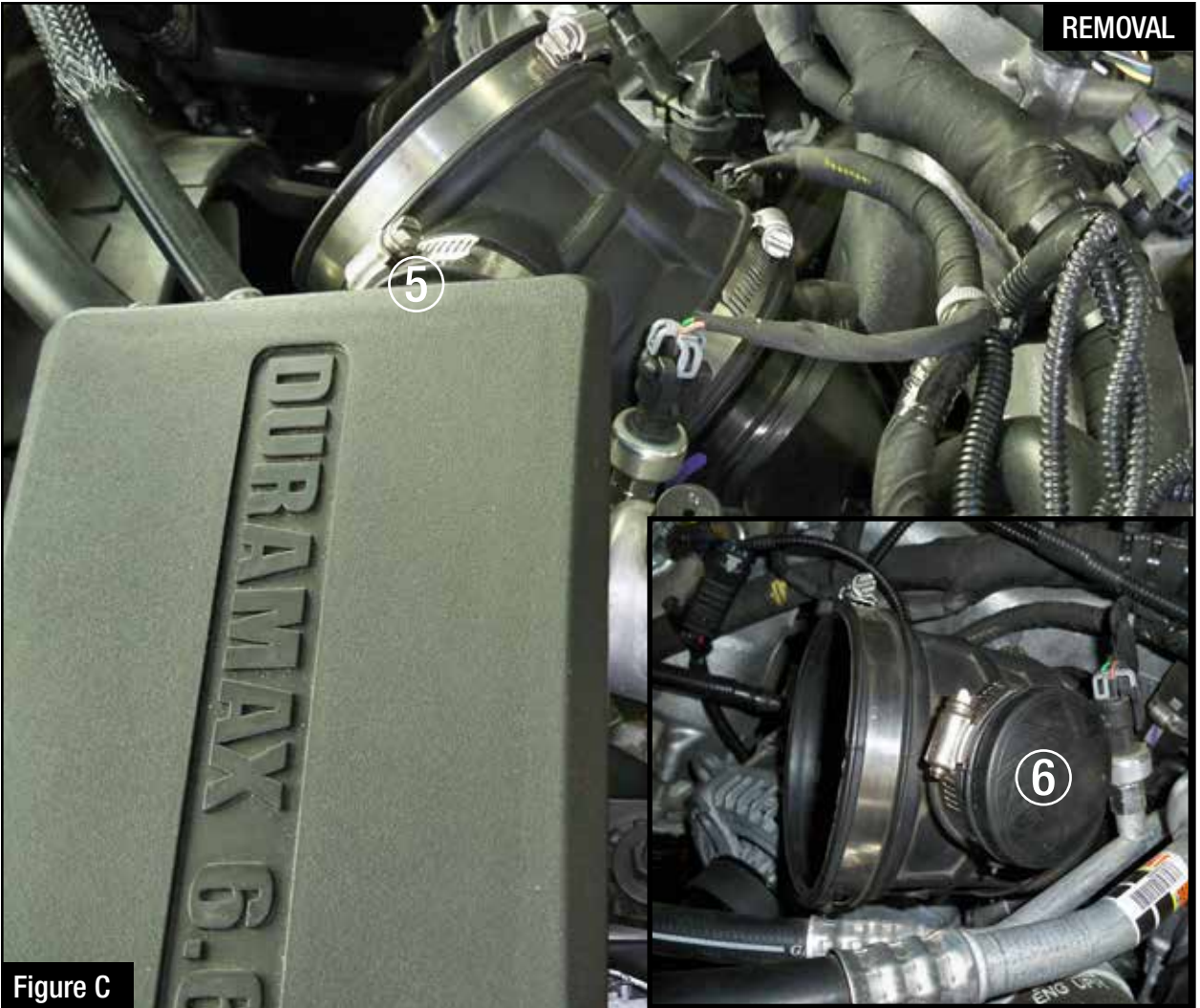
**Figure C****Refer to Figure C for Step 5**

Step 5: If you wish to remove the resonator, loosen the clamp ⑤ at the resonator with an 8mm nut driver. Remove the resonator from the stock coupler. Insert resonator plug ⑥ into the stock coupler and tighten the clamp.



Figure D

Refer to Figure D for Step 6

Step 6: Remove the coolant line clip (7) from the airbox then remove the factory airbox (8) out of the vehicle. (Use an upward pull to release the retaining plug).



Figure E

Refer to Figure E for Step 7

Step 7: Install the supplied short (21") trim seal (9) onto the top opening at the airbox (10).



Figure F

Refer to Figure F for Steps 8-9

Step 8: Remove the retaining plug (11) from the bottom of the factory airbox and transfer it to the aFe airbox.

Step 9: Install the trim seal (12) on the opening of the aFe airbox.

**Figure G****Refer to Figure G for Steps 10-11**

Step 10: Slide the aFe filter into the aFe housing. Install the aFe filter using a #2 Phillips screwdriver. Tighten all (x4) screws.

Step 11: Install the supplied bellows coupler (13) onto the air filter using the supplied #80 clamp (14) . Tighten the clamp.



Figure H

Refer to Figure H for Step 12

Step 12: Install the aFe airbox assembly into the vehicle. Firmly push it into the factory mounting grommets.



Figure I

Refer to Figure I for Steps 13-14

Step 13: Remove the MAF sensor with gasket (15) from the factory airbox using a T20 Torx drive.

Step 14: Install the MAF sensor with gasket into the aFe intake tube using the supplied M4 screws and a T20 Torx drive.



Figure J

Refer to Figure J for Step 15

Step 14: Place the #72 clamp (16) onto the filter coupler (17). Do NOT tighten clamp.



Figure K

Refer to Figure K for Steps 16-17

Step 16: Slide the intake tube into the filter coupler (18) and then into the stock coupler (19).

Step 17: Align the intake tube correctly then tighten all clamps.



Figure L

Refer to Figure L for Steps 18-19

Step 18: Reconnect the MAF sensor harness. ②0

Step 19: Make sure all clamps and connections are secured. Your installation is now complete! Thank you for choosing aFe POWER.

NOTE: Check all bolts, clamps, and connectors after 100-200 miles.



Pro DRY S Air Filter



P/N: 21-90098

Pro 5R Air Filter



P/N: 23-91129

Pro DRY S Restore Kit



P/N: 90-59999

Blue Squeeze Restore Kit



P/N: 90-50501

Intercooler Tubes



P/N: 46-20334-B

Rebel XD Series Exhaust



P/N: 49-44089-B (Blk. Tips)
49-44089-P (Pol. Tips)

Downpipe Back Exhaust

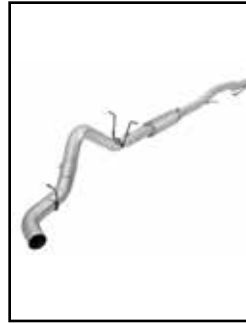

P/N: 49-44087-B (Blk. Tip)
49-44087-P (Pol. Tip)

DPF-Back Exhaust



P/N: 49-44085-B (Blk. Tip)
49-44085-P (Pol. Tip)

Sprint Booster V3.



P/N: 77-14003

DFS Fuel System



P/N: 42-14023 (Full-Time)
42-14024 (Part-Time)

SCORCHER HD Module



P/N: 77-44010

Rear Differential Cover



P/N: 46-70012-WL (w/ Oil)

aFe provides the best in performance air intake systems equipment.