

advanced FLOW engineering Quantum Air Intake

Instruction Manual P/N: 53-10005D / 53-10005R

Make: **Chevrolet** Model: **Silverado HD** Year: **2007.5-2010** Engine: **V8-6.6L Duramax (LMM)**

Make: **GMC** Model: **Sierra HD** Year: **2007.5-2010** Engine: **V8-6.6L Duramax (LMM)**

Note: **Includes Denali Trim.**



- Please read the entire instruction manual before proceeding.
- Ensure all components listed are present.
- Ensure you have all necessary tools before proceeding.
- Do not attempt to work on your vehicle when the engine is hot.
- Disconnect the negative battery terminal before proceeding.
- Retain factory parts for future use.

Label	Qty.	Description	Part Number
A1	1	Air Filter (Pro DRY S)	21-90098
A2	1	Air Filter (Pro 5R)	23-91129
B	1	Tube	05-54004B1
C	1	Housing	05-54006B2
D	1	Filter, Elbow	05-54004B3
E	1	Coupling, Filter Adaptor	05-01476
F	2	Clamp, #072	03-50010
G	1	Seal Trim 7/16" (26")	05-00072
H	2	Screws, Torx M4	03-50491
I	1	Grommet, Ait Temp Sensor	03-50033
J	1	Cap: 1/2"	03-50103
K	1	Clamp, #088	03-50005
L	1	Coupling, Silicone Bellow	05-01456
M	1	Coupling, Silicone Hump	05-01201
N	2	Clamp, #080	03-50011

Installation will require the following tools:

8mm Nut driver, T20 torx bit or driver, Phillips #3 screwdriver.

Note: Legal in California for use on race vehicles only. The use of this device on vehicles used on public streets or highways is strictly prohibited in California and others states that have adopted California emission regulations.

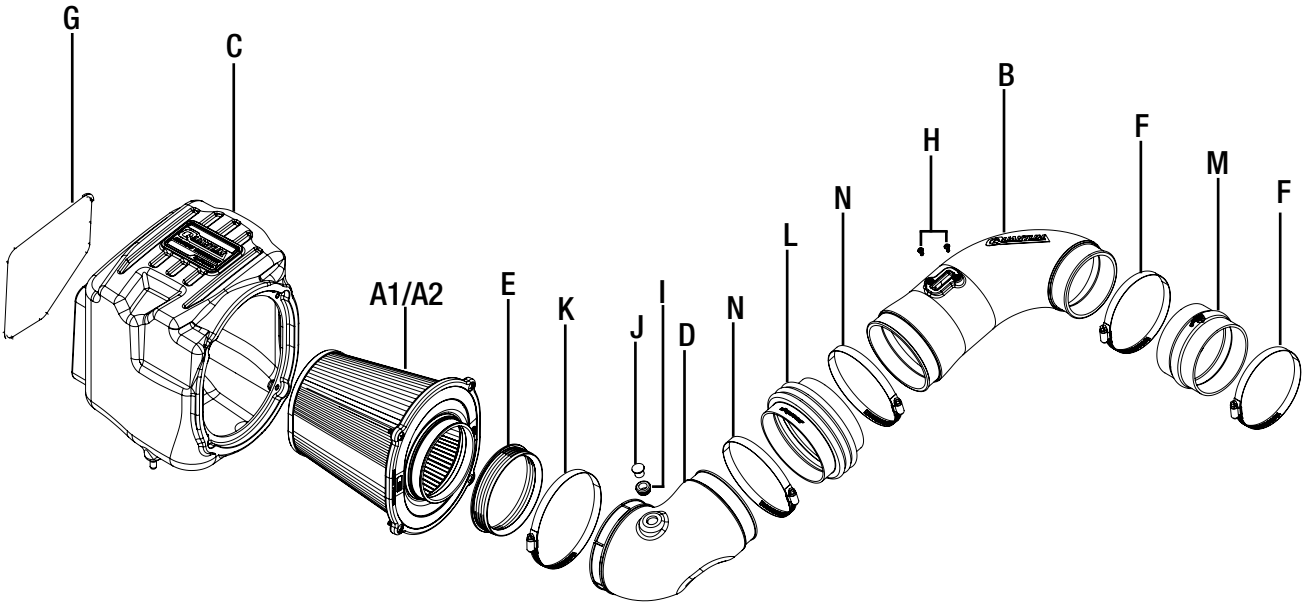



Refer to Figure A for Steps 1-4

- Step 1: Disconnect the Mass Air Flow sensor. ①
- Step 2: Using an 8mm nut driver, loosen the clamps ② from the intake tube.
- Step 3: Remove the factory intake tube. ③
- Step 4: Remove the factory airbox ④ out of the vehicle. (Use an upward pull to release the retaining plug).

**Figure B****Refer to Figure B for Steps 5-6**

Step 5: Slide the aFe filter into the aFe housing. Install the aFe filter using a #3 Phillips screwdriver. Tighten all (x4) screws.

Step 6: Install the supplied filter coupling (5) onto the air filter.



Figure C

Refer to Figure C for Steps 7-8

Step 7: Remove the retaining plug (6) from the bottom of the factory airbox and transfer it to the aFe housing.

Step 8: Install the supplied trim seal (7) on the opening of the aFe housing.



REMOVAL



Figure D

Refer to Figure D for Step 9

Step 9: On the mounting plate, move the front right mounting grommet (8) to the hole on the left. Install the aFe housing assembly into the vehicle. Firmly push it into the factory mounting grommets.

**Figure E****Refer to Figure E for Steps 10-11**

Step 10: Remove the filter minder and grommet (9) from factory airbox. Install the grommet into the aFe elbow tube and then push in the filter minder. If you choose not to use the filter minder, just plug off the hole with the supplied grommet and cap.

Step 11: Place the supplied #088 (10) clamp onto the elbow tube slot with cuts section.



Refer to Figure F for Steps 12-13

Step 12: Install the aFe elbow tube assembly onto the filter coupling. Align elbow tube but do not tighten the clamp.

Step 13: Place the supplied #080 (11) clamp and bellows coupling (12) onto the aFe elbow tube.

**Figure G****Refer to Figure G for Steps 14-15**

Step 14: Slide the supplied hump coupling (13) and #072 clamp (14) over the turbo inlet.

Step 15: Place the other supplied #072 (15) clamp over the hump coupling and #080 (16) clamp over the bellows couplings.

**Figure H****Refer to Figure H for Steps 16-17**

Step 16: Using a T-20 Torx driver, remove the MAF sensor (17) from the factory airbox.

Step 17: Install the MAF sensor into the aFe intake tube using the provided M4 screws and a T-20 Torx driver.

**Figure I****Refer to Figure I for Steps 18-20**

Step 18: Slide the aFe intake tube into the bellows coupling, then into the coupling at the turbo inlet.

Align tubes and clamps, then tighten all the clamps with an 8mm nut driver.

Step 19: Reconnect the MAF sensor. ⑱

Step 20: Check all the components are tight and secure. Your installation is now complete. Thank you for choosing aFe POWER.

NOTE: Check all bolts, clamps, and connectors after 100-200 miles.

Rely on premium performance air intake systems by aFe if you're looking for quality and efficiency.