

advanced FLOW engineering Quantum Air Intake

Instruction Manual P/N: 53-10004D / 53-10004R

Make: **Ford** Model: **F-250/F-350/F-450/F-550** Year: **2017-2018** Engine: **V8-6.7L (td) Power Stroke**



- Please read the entire instruction manual before proceeding.
- Ensure all components listed are present.
- If you are missing any of the components.
- Ensure you have all necessary tools before proceeding.
- Do not attempt to work on your vehicle when the engine is hot.
- Disconnect the negative battery terminal before proceeding.
- Retain factory parts for future use.

Label	Qty.	Description	Part Number
A1	1	Air Filter (Pro DRY S)	21-90103
A2	1	Air Filter (Pro 5R)	23-91132
B	1	Tube	05-53006B1
C	1	Housing	05-53006B2
D	1	Coupling, Silicone Bellow	05-01457
E	1	Coupling, Silicone Hump	05-01204
F	1	Washer: M6	03-50070
G	2	Screw, Torx: M4	03-50491
H	1	Screw, Hex Hd: M6	03-50057
I	1	Fixing Clamp, 3/4"	03-50234
J	3	Clamp, #072	03-50010
K	1	Clamp, #080	03-50011
L	1	Grommet	03-50033
M	1	Cap	03-50103

Installation will require the following tools:

7mm, 8mm, 10mm, nut driver or socket and extension, T-20 Torx, Phillips #2 screwdriver.

Note: Legal in California for use on race vehicles only. The use of this device on vehicles used on public streets or highways is strictly prohibited in California and others states that have adopted California emission regulations.

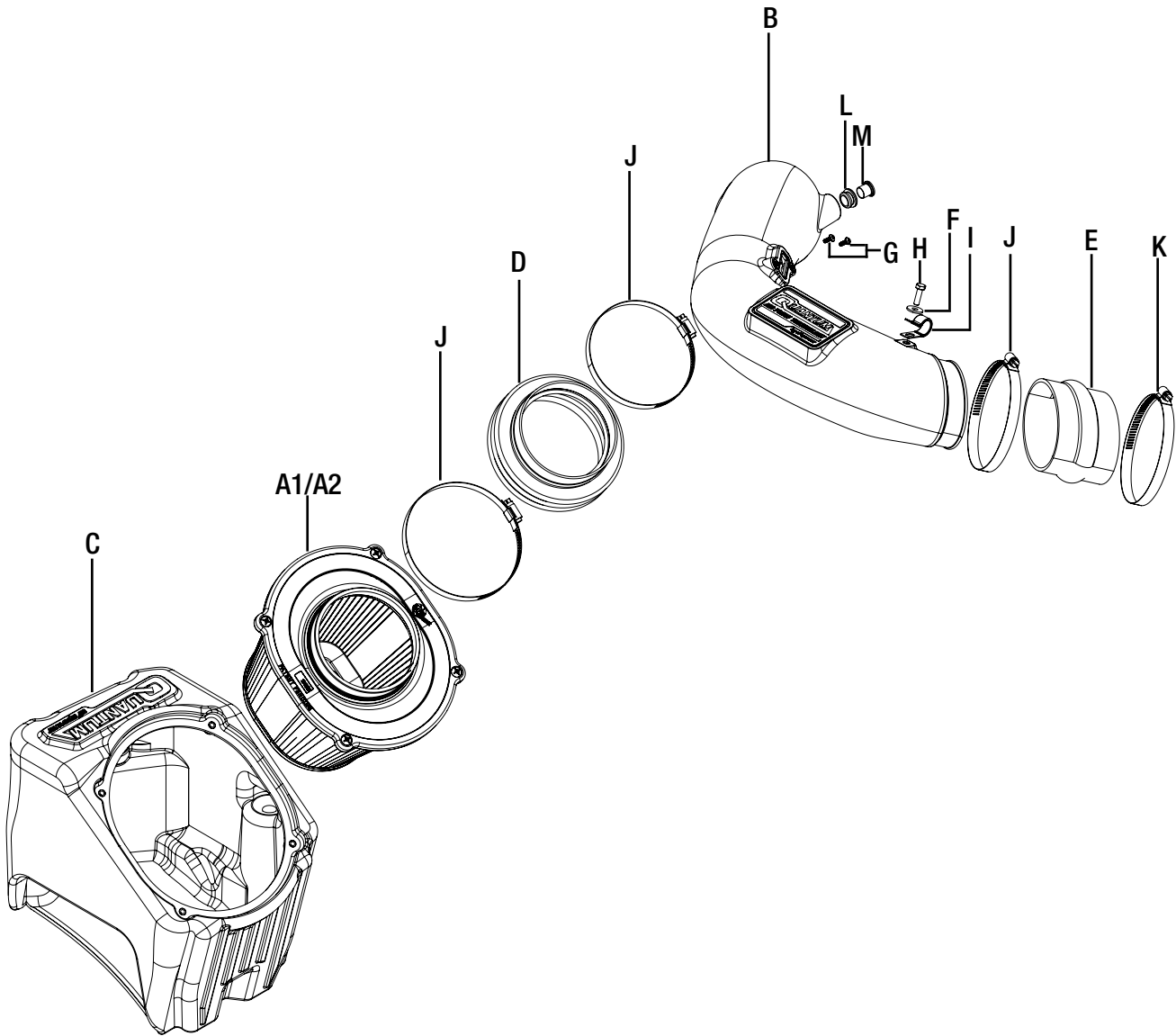

**Figure A****Refer to Figure A for Step 1**

Step 1: Using a 7mm nut driver, loosen the clamps ① at the turbo inlet and the airbox. Remove the hose ② from the intake tube clip and remove the intake tube ③.

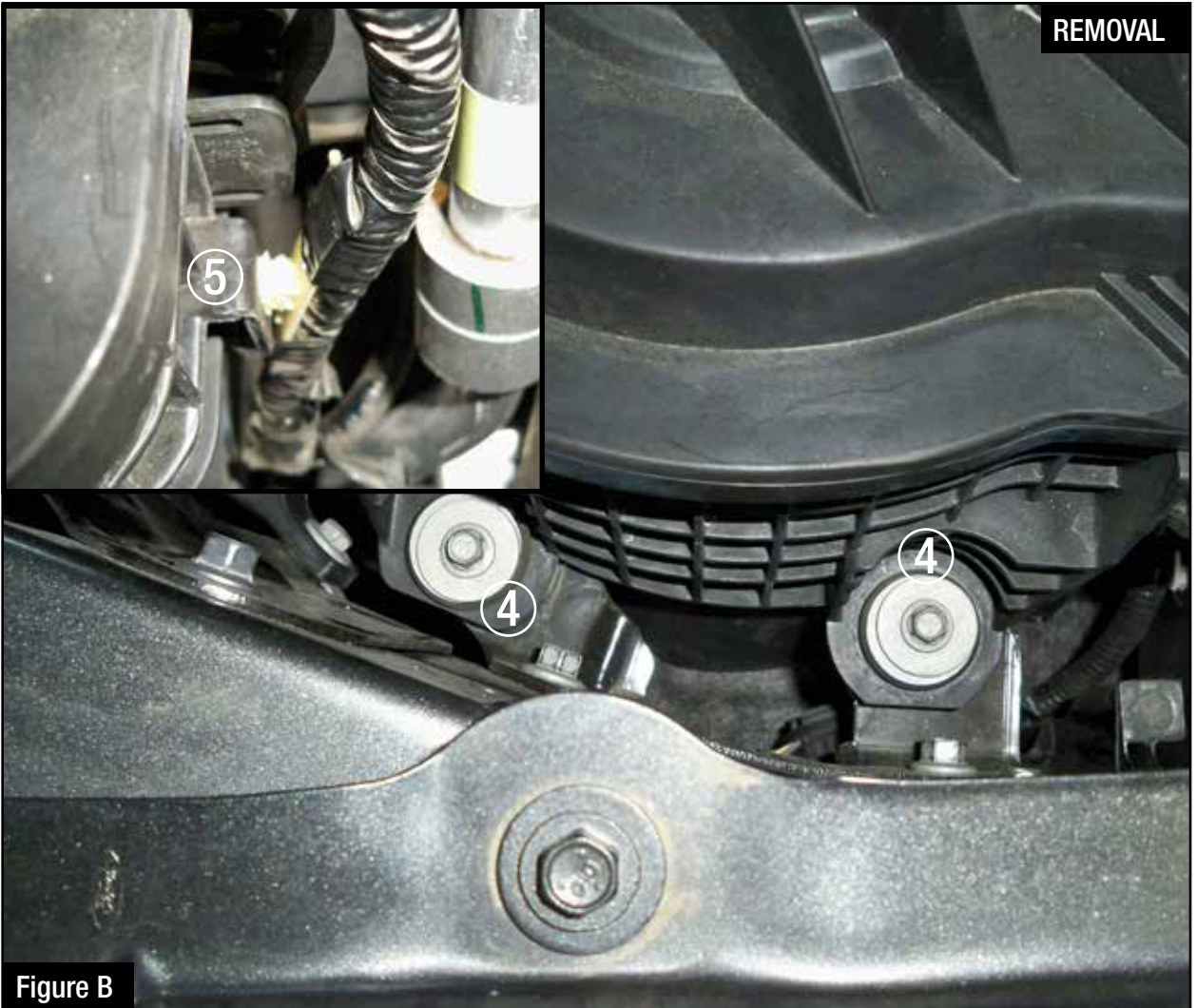

Refer to Figure B for Steps 2-3

Step 2: Using a 10mm nut driver, remove the two screws (4) securing the airbox to the frame and set them aside for later use.

Step 3: Remove the wire clip (5) attached to the airbox.

**Figure C****Refer to Figure C for Steps 4-5**

Step 4: Slide back the red locking tab on the bottom side of the MAF sensor connector⑥ and then disconnect the sensor.

Step 5: Remove the OE airbox by pulling in an upward motion.



Refer to Figure D for Step 6

Step 6: Remove the factory grommets with metal inserts (7) from the OE airbox and install them on the aFe housing.

**Figure E****Refer to Figure E for Steps 7-8**

Step 7: Slide the aFe filter into the aFe housing. Install the aFe filter using a #2 Phillips screwdriver.
Tighten all four screws.

Step 8: Install the supplied bellows coupling (8) onto the air filter using the supplied #80 clamp (9).
Tighten the clamp.

INSTALL



Figure F

Refer to Figure F for Step 9

Step 9: Install the housing assembly into the vehicle by pushing it in to the factory grommet. Secure the housing assembly with the two screws (10) removed in Step 2. Tighten both screws.



INSTALL



Figure G

Refer to Figure G for Steps 10-12

Step 10: Remove the factory filter minder and grommet (11) and install them onto the aFe intake tube.

Step 11: Using a T20 Torx driver, remove the MAF sensor (12) from the OE airbox.

Step 12: Install the MAF sensor in the aFe intake tube using the provided M4 screws and a T20 Torx driver.

**Figure H****Refer to Figure H for Steps 13-14**

Step 13: Slide the supplied hump coupling (13) over the turbo inlet with one of the supplied #72 clamp (14). Tighten the clamp.

Step 14: Place the other provided #72 clamps (15) onto the hump coupling and onto the filter coupling.

**Figure I****Refer to Figure I for Steps 15-17**

Step 15: Slide the aFe intake tube into the coupling at the filter, then install the intake tube into the coupling at the turbo inlet. Tighten all the clamps with an 8mm nut driver.

Step 15: Reconnect the MAF sensor (16) .

Step 16: Secure the hose to the tube with the provided fixing clamp, 6mm screw and washer (17) . Using a 10mm nut driver, tighten the screw. Check all the components are tight and secure. Your installation is now complete. Thank you for choosing aFe POWER.

NOTE: Check all bolts, clamps, and connectors after 100-200 miles.