

advanced FLOW engineering Quantum Air Intake

Instruction Manual P/N: 53-10002D / 53-10002R

Make: **RAM** Model: **2500/3500/4500/5500** Year: **2013-2018** Engine: **L6-6.7L (td) Cummins**



- Please read the entire instruction manual before proceeding.
- Ensure all components listed are present.
- If you are missing any of the components.
- Ensure you have all necessary tools before proceeding.
- Do not attempt to work on your vehicle when the engine is hot.
- Disconnect both the negative battery terminal before proceeding.

Retain factory parts for future use.

Label	Qty.	Description	Part Number
A1	1	Air Filter (Pro 5R)	23-91129
A2	1	Air Filter (Pro DRY S)	21-90098
B	1	Housing	05-52005B2
C	1	Tube	05-52005B1
D	1	Coupling, Silicone Bellow	05-01457
E	1	Coupling, Silicone Elbow 90 Deg.	05-01464
F	1	Hose, Silicone Breather: 3/4"ID (6")	05-01475
G	3	Screw, Torx: M4	03-50490
H	1	Clamp, Mini #012	03-50023
I	2	Clamp, #072	03-50010
J	1	Clamp, #064	03-50006
K	1	Clamp, #080	03-50011

Installation will require the following tools:

7mm, 8mm and 13mm socket or nut driver, ratchet and extension, pliers, Phillips #2 screwdriver, T30 torx and T20 torx.

aFe are proud to offer a high quality product at the industries most competitive pricing!

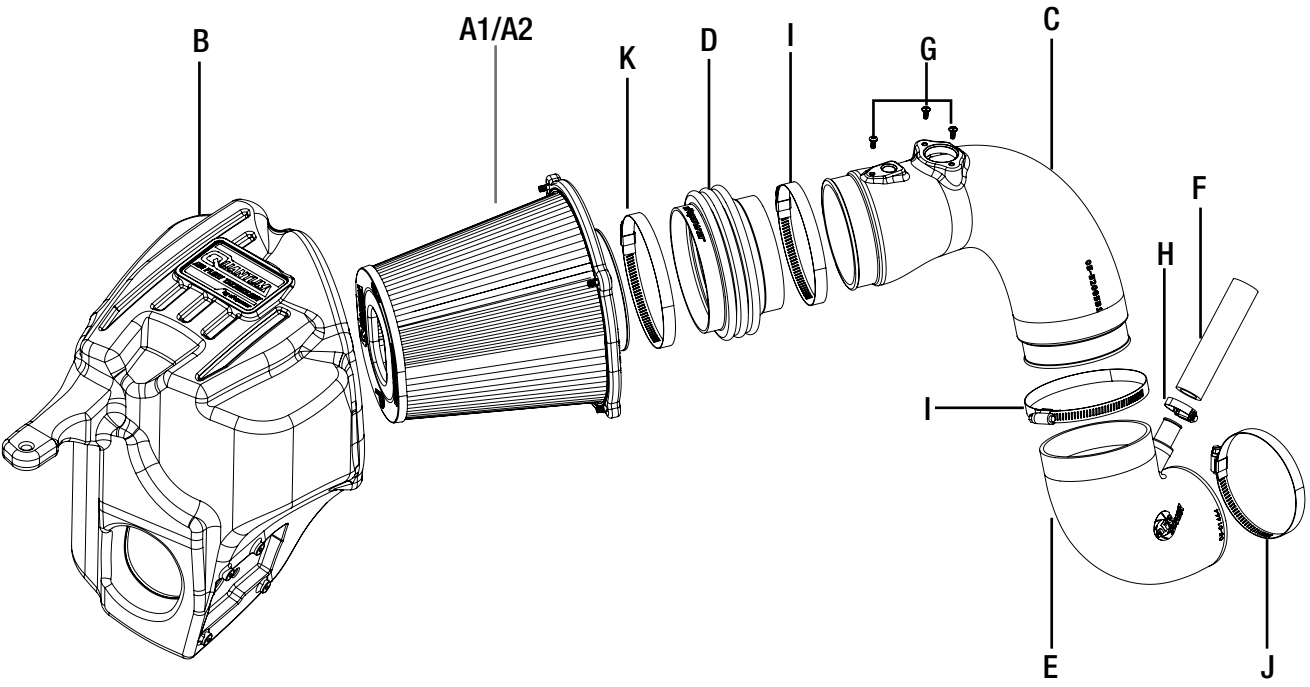



Refer to Figure A for Steps 1-3

Step 1: Disconnect the wiring harness retaining clip, the Mass Air Flow (MAF) sensor (1) and the temperature sensor (2).

Step 2: Remove the screw (3) holding down the factory airbox with a 13mm socket and ratchet.

Step 3: Using an 8mm nut driver, loosen the clamp (4) at the airbox.

**Figure B****Refer to Figure B for steps 4-5**

Step 4: Disconnect the crank case vent line (5) using pliers (factory clamp will be re-used).

Step 5: Loosen the clamp (6) connecting the factory intake tube to the turbocharger.



Refer to Figure C for Steps 6-7

Step 6: Remove the intake tube.

Step 7: Lift the factory airbox up out of the vehicle until you are able to reach the wiring harness ⑦ from the Ram Active Air mechanism. Disconnect the harness and retaining clip. Then pull the factory airbox out of the vehicle.



Figure D

Refer to Figure D for Steps 8-11

Step 8: Open the factory airbox and remove the filter.

Step 9: Disconnect the ball (8) joint connected to the flap.

Step 10: Using a T30 torx driver, remove the screws (9) securing the Ram Active Air mechanism. Those screws will be re-used to install the Ram Active Air mechanism onto the aFe airbox.

Step 11: Remove the flap (10) from the motor shaft. This will require a lot of force. Take the Ram Active Air motor and flap off the factory airbox.



Figure E

Refer to Figure E for Steps 12-13

Step 12: Transfer the Ram Active Air motor to the aFe airbox. Re-install the flap on the motor shaft by firmly pushing on it.

Step 13: Secure the assembly to the aFe airbox using the factory screws (11). Make sure the flap is fully engaged to the motor shaft.



Figure F

Refer to Figure F for Steps 14-15

Step 14: Slide the aFe filter into the aFe airbox. Install the aFe filter using a #2 Phillips screwdriver. Tighten all (x4) screws.

Step 15: Install the supplied bellows coupler (12) onto the air filter using the supplied #80 clamp (13). Tighten the clamp.



Figure G

Refer to Figure G for Steps 16-17

Step 16: Install the airbox assembly into the vehicle. Re-connect the wiring harness to the Ram Active Air mechanism. Firmly push the airbox into the factory mounting grommets.

Step 17: Re-install the factory screw (14) removed in Step 2 to secure the airbox. Tighten the screw.

**Refer to Figure H for Step 18**

Step 18: Transfer the MAF sensor (15) and the temperature sensor (16) from the factory airbox to the aFe tube. Use the supplied M4 screws to secure the sensors using a T20 torx.

**Figure I****Refer to Figure I for Steps 19-20**

- Step 19: Install the supplied silicone hose (17) on the coupler fitting and secure with the supplied mini clamp (18). Slide the factory clamp (19) on the other end of the silicone hose.
- Step 20: Place the supplied #064 clamp (19) on the small end of elbow the coupler (20) . Install onto the turbo inlet and do NOT tighten yet.

**Refer to Figure J for Steps 21-23**

- Step 21: Place the two #072 clamps (21) on the filter coupler (22) and the elbow coupler end (23).
- Step 22: Install the aFe tube into the vehicle by sliding into the filter coupler then the elbow coupler. Align the tube and the elbow coupler, then tighten the clamps.
- Step 23: Connect the silicone hose (24) to the factory crankcase line. Using pliers, secure it with the factory clamp (25).

**Figure K****Refer to Figure K for Steps 24-25**

Step 24: Re-connect the MAF sensor (26) and temperature sensor (27) harness.

Step 25: Verify all connections are secured. Your installation is now completed.

NOTE: Verify all connections are secured after 100-200 miles.