

advanced FLOW engineering

Instruction Manual P/N: 52-74202-C

Make: **Chevrolet** Model: **Corvette Z06 (C7)** Year: **2015-2017** Engine: **V8-6.2L (sc)**



- Please read the entire instruction manual before proceeding.
- Ensure all components listed are present.
- If you are missing any of the components, call customer support.
- Ensure you have all necessary tools before proceeding.
- Do not attempt to work on your vehicle when the engine is hot.
- Disconnect the negative battery terminal before proceeding.
- Retain factory parts for future use.

| Label | Qty. | Description | Part Number |
|-------|------|------------------------------------|-------------|
| A1 | 1 | Air Filter (Pro DRY S) | 21-90088 |
| A2 | 1 | Air Filter (Pro 5R) | 24-90088 |
| B | 1 | Tube | 05-74202C1 |
| C | 1 | Housing | 05-74202C2 |
| D | 2 | Screw, Torx T20 M4 x .7x8 | 03-50491 |
| E | 1 | Threadlocker | 03-50162 |
| F | 2 | Clamp, T-Bolt (3-3/4 - 4-1/16) | 03-50265 |
| G | 1 | Vent Fitting | 05-01338 |
| H | 1 | Coupling, Silicone Hump | 05-01375 |
| I | 1 | Hose, Coolant 3/8" ID (15" inches) | 05-01357 |
| J | 2 | Mini Clamp | 03-50025 |
| K | 1 | Cable Tie | 05-60167 |
| L | 1 | Black Series Emblem | 06-00143 |

Tools needed: 7mm, 8mm, 10mm and 7/16 Socket or nut driver, Ratchet and extension, flat head screw driver, razor blade, & Torx T20 Driver.

Note: Legal in California for use on race vehicles only. The use of this device on vehicles used on public streets or highways is strictly prohibited in California and others states that have adopted California emission regulations.

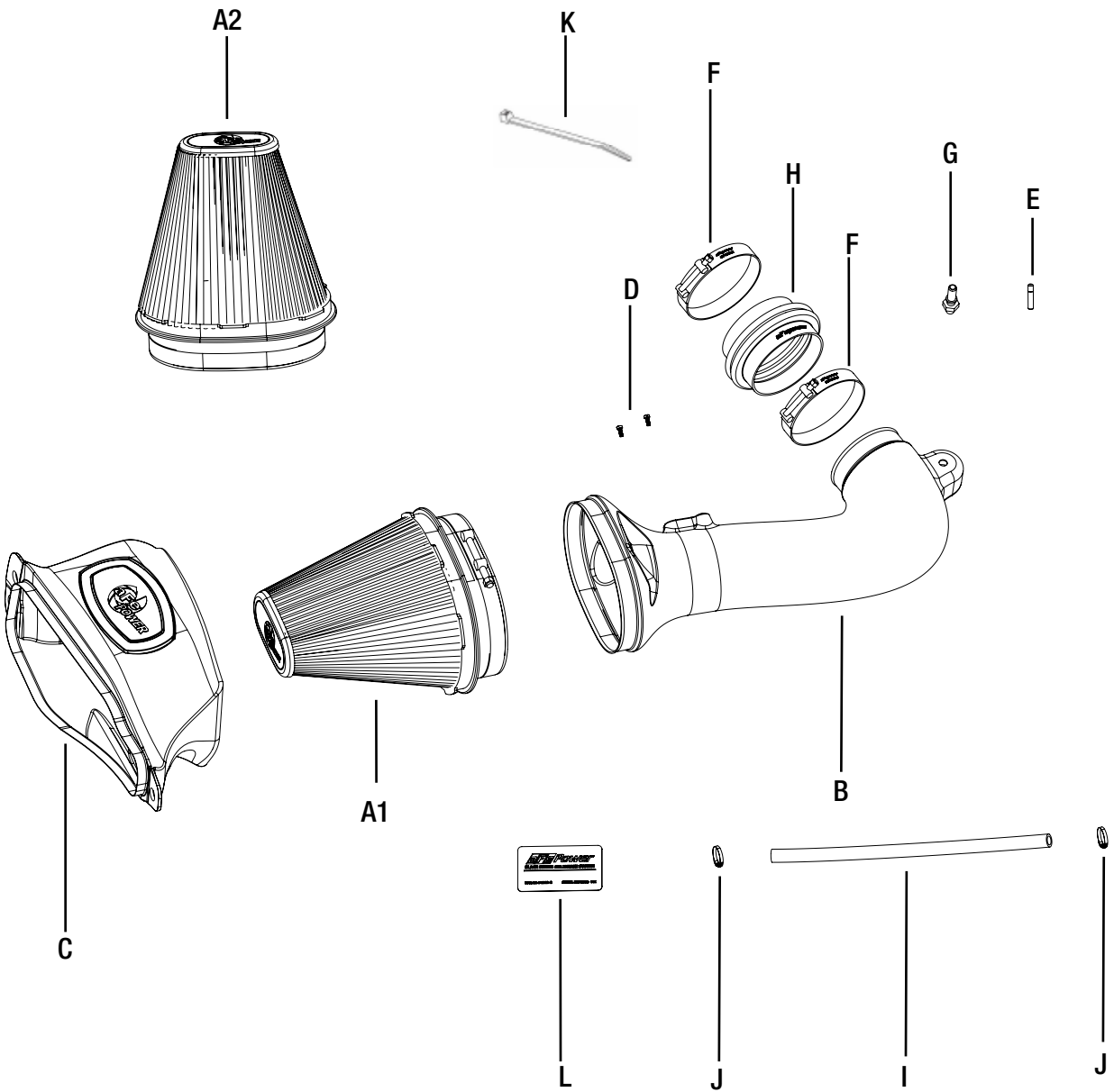



Figure A

Refer to Figure A for Step 1

Step 1: Remove the radiator air outlet channel by removing the four screws securing it with a 7mm socket or nut driver.



Figure B

Refer to Figure B for Steps 2-3

Step 2: Disconnect the Mass Air Flow (MAF) Sensor harness.

Step 3: Loosen the clamps at the throttle body and at the housing. Disconnect the vent hose then remove the factory intake tube out of the vehicle.



Refer to Figure C for Step 4

Step 4: Remove the two 10mm screws holding the factory intake box and pull it out of the mounting grommet then out of the vehicle.

**Figure D****Refer to Figure D for Steps 5-6**

Step 5: Transfer the three mounting grommet from the factory air box to the aFe Housing. Add the two factory metal inserts.

Step 6: Slide the filter into the housing and push it in until it locks into place.

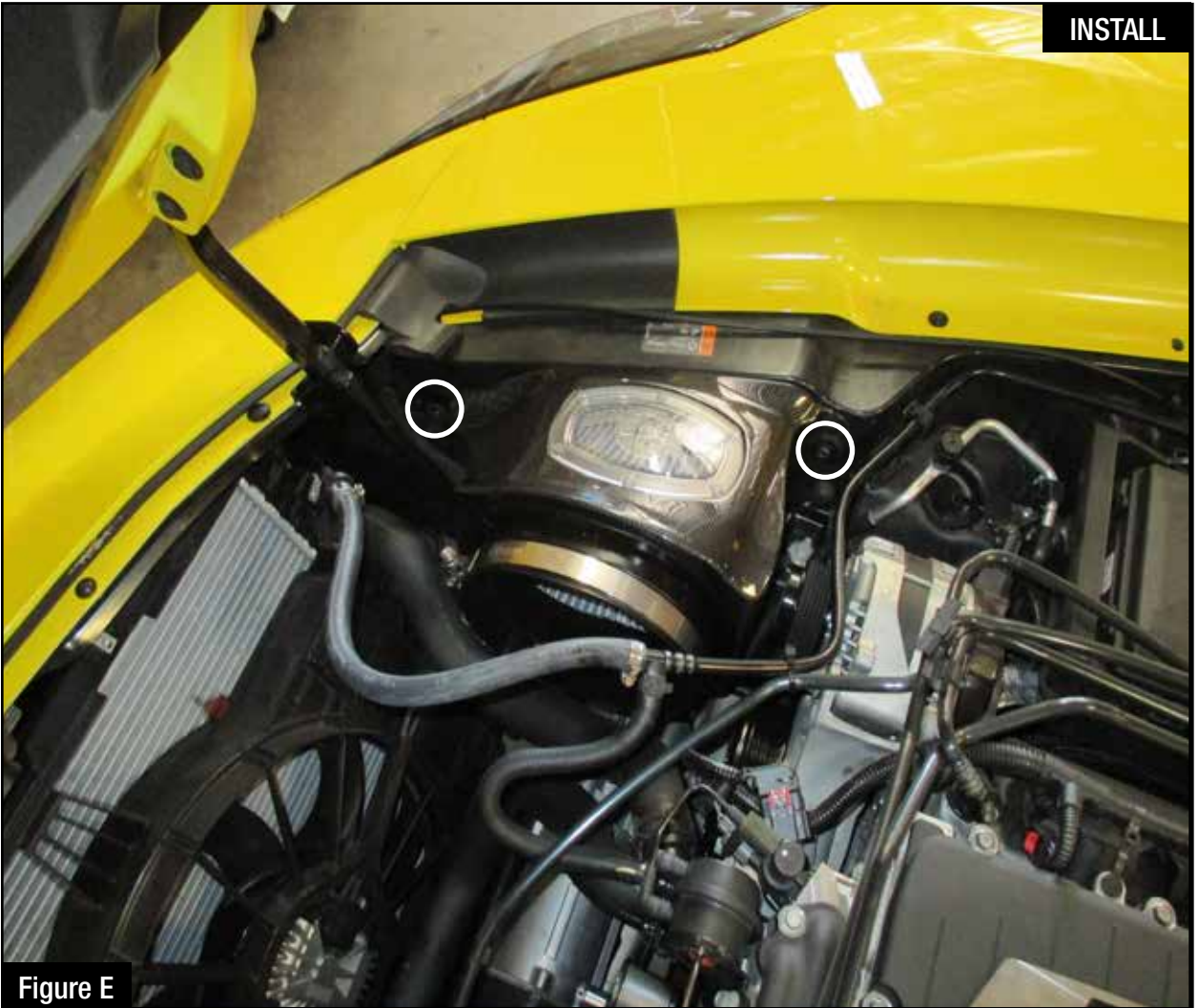

Figure E

Refer to Figure E for Step 7

Step 7: Install the aFe filter/housing assembly into the vehicle. Push it on the factory stud and secure it using the two factory 10 mm screws removed at step 4.



Figure F

Refer to Figure F for Steps 8-9

Step 8: Remove the MAF sensor from the factory air box. Install it on the aFe tube using factory O-ring and supplied m4 screws.

Step 9: Screw the provided vent fitting into the aFe tube. Apply some of the furnished threadlocker to guarantee a perfect seal.

**Figure G****Refer to Figure G for Steps 10-14**

Step 10: Install the silicone coupling over the throttle body.

Step 11: Install the aFe tube into the vehicle. Slide the tube first into the filter then the coupling on the throttle body.

Step 12: Align the tube correctly then install t-bolt clamps over coupling. You may need to open the T-bolt clamps by removing the nut completely. Then install it around the coupling and close it by re-installing the nut. Tighten all clamps.

Step 13: Reconnect the MAF sensor.

Step 14: Connect the vent hose onto the aluminum fitting.



Figure H

Refer to Figure H for Steps 15-16

Make sure engine is cold before disconnecting the coolant line.

Step 15: The coolant line needs to be re-routed to make clearance for the hood vent. Locate the short hard plastic coolant line between the check valve and the T-fitting. Put a shop towel under it to catch the coolant excess when disconnected.

Step 16: With a sharp blade, slice open the hard plastic coolant line on both sides and remove it.

**Figure I****Refer to Figure I for Steps 17-19**

Step 17: Replace the hard plastic line with the furnished hose. Install mini clamps on both ends to secure it.

Step 18: Route the hose over the tube like shown in picture. It will seat under the radiator air outlet

Make sure it doesn't kink or put pressure on the MAF sensor. If necessary you can rotate the factory wing clamp.

Step 19: Use the furnished cable tie to secure the coolant line to the vent hose and prevent any contact with the serpentine belt.



Figure J

Refer to Figure J for Steps 20-22

Step 20: Re-install the factory radiator air outlet.

Step 21: Stick the aFePower Black series Plate where desired.

Step 22: Make sure all clamps and connections are secured. Your installation is now completed.

NOTE: Check all bolts, clamps and connectors after 200 miles.



Pro DRY S Air Filter



P/N: 21-90088

Pro 5R Air Filter



P/N: 24-90088

Pro DRY S Restore Kit



P/N: 90-59999

Blue Squeeze Restore Kit



P/N: 90-50501

Axle-Back Exhaust



P/N: 49-34082-C (C/F Tips)
49-34082-P (Pol Tips)

Gas Shocks



P/N: 420-401002-J

Suspension Package 1

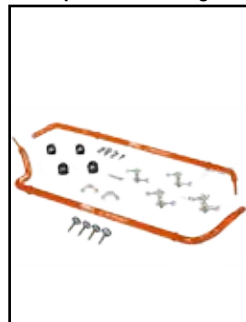

P/N: 510-401001-N

Suspension Package 2



P/N: 520-401002-N

Sway Bars



P/N: 440-401003-N

Lowering Kit



P/N: 410-401001-A

Coilovers



P/N: 430-401004-N

Rear Toe Links



P/N: 460-401006-A

Warranty

General Terms:

- aFe warrants their products to be free from manufacturer's defects due to workmanship and material.
- This warranty applies only to the original purchaser of the product and is nontransferable.
- Proof of purchase of the aFe product is required for all warranty claims.
- Warranty is valid provided aFe instructions for installation and/or cleaning were properly followed.
- Proper maintenance with regular inspections of product is required to insure warranty coverage.
- Damage due to improper installation, abuse, unauthorized repair or alteration is not warranted.
- Incidental or consequential damages or cost, including installation and removal of part, incurred due to failure of aFe product is not covered under this warranty.
- All warranty is limited to the repair and/or replacement of the aFe part. To request Return Goods Authorization ("RGA"). Upon receipt of the RGA, you must return the product to the address provided in the RGA, freight prepaid and accompanied with a dated proof of purchase and the RGA. Upon receipt of the defective product and upon verification of proof of purchase, aFe will either repair or replace the defective product within a reasonable time, not to exceed thirty days.

| Product Category | P/N Prefix | Warranty duration |
|----------------------------------|------------------------|--------------------------|
| Direct OE Replacement Filters | 10, 11, 30, 31, 71, 73 | Life of the vehicle |
| Racing Filters | 18 | 1 year |
| Universal | 21, 24, 72 | 2 years |
| Air Intake Systems | 50, 51, 54, 55, 75 | 2 years |
| Exhaust Systems | 49 | 2 years |
| Intercoolers & Intercooler Tubes | 46-2 | 2 years |
| Intake Manifolds | 46-1 | 2 years |
| Differential Cover | 46-7 | Life of the vehicle |
| Exhaust Manifolds | 46 | 2 years |
| Throttle Body Spacers | 46-3 | 2 years |
| Fluid Filters | 44 | 90 days |
| Pre-Filters | 28 | 2 years |
| Heavy Duty OE Replacement | 70 | 2 years |
| PowerSports OE Replacement | 81, 87 | 2 years |
| PowerSports Intake Systems | 85 | 2 years |

No other warranty expressed or implied applies nor is any person or advanced FLOW engineering authorized to assume any other warranty. Some States do not allow the exclusion or limitation of incidental or consequential damages or do not allow limitations on how long an implied warranty lasts, so the above limitations or exclusions may not apply to you. This warranty gives you specific legal rights, and you may also have other rights which vary from State to State.