

advanced FLOW engineering Rapid Induction Cold Air Intake System

Instruction Manual P/N: 52-10001D / 52-10001R

Make: Ford

Model: Ranger

Year: 2019-2021

Engine: L4-2.3L (t)



- Please read the entire instruction manual before proceeding.
- Ensure all components listed are present.
- Ensure you have all necessary tools before proceeding.
- Do not attempt to work on your vehicle when the engine is hot.
- Retain factory parts for future use.

Label	Qty.	Description	Part Number
A1	1	Air Filter (Pro 5R)	24-90113
A2	1	Air Filter (Pro DRY S)	21-90113
B	1	Tube	05-5210001B1
C	1	Housing	05-5210001B2
D	1	Adaptor, Air Temp Sensor	05-01454
E	2	Clamp, 048 (2-9/16" - 3-1/2 ")	03-50007
F	1	Grommet, Rubber	03-50167
G	1	Coupling, Silicone Hump: 3"ID x 2-1/4"L	05-01245
H	1	Fitting, Large	05-01339
I	1	Seal Trim (length 32")	05-00072

Installation will require the following tools:

Panel clip remover or small flat-head screwdriver, 7mm & 8mm nut drivers.

Emissions Disclaimer: This product is not currently CARB exempt and is not available for purchase in California or for use on any vehicle registered with the California Department of Motor Vehicles.

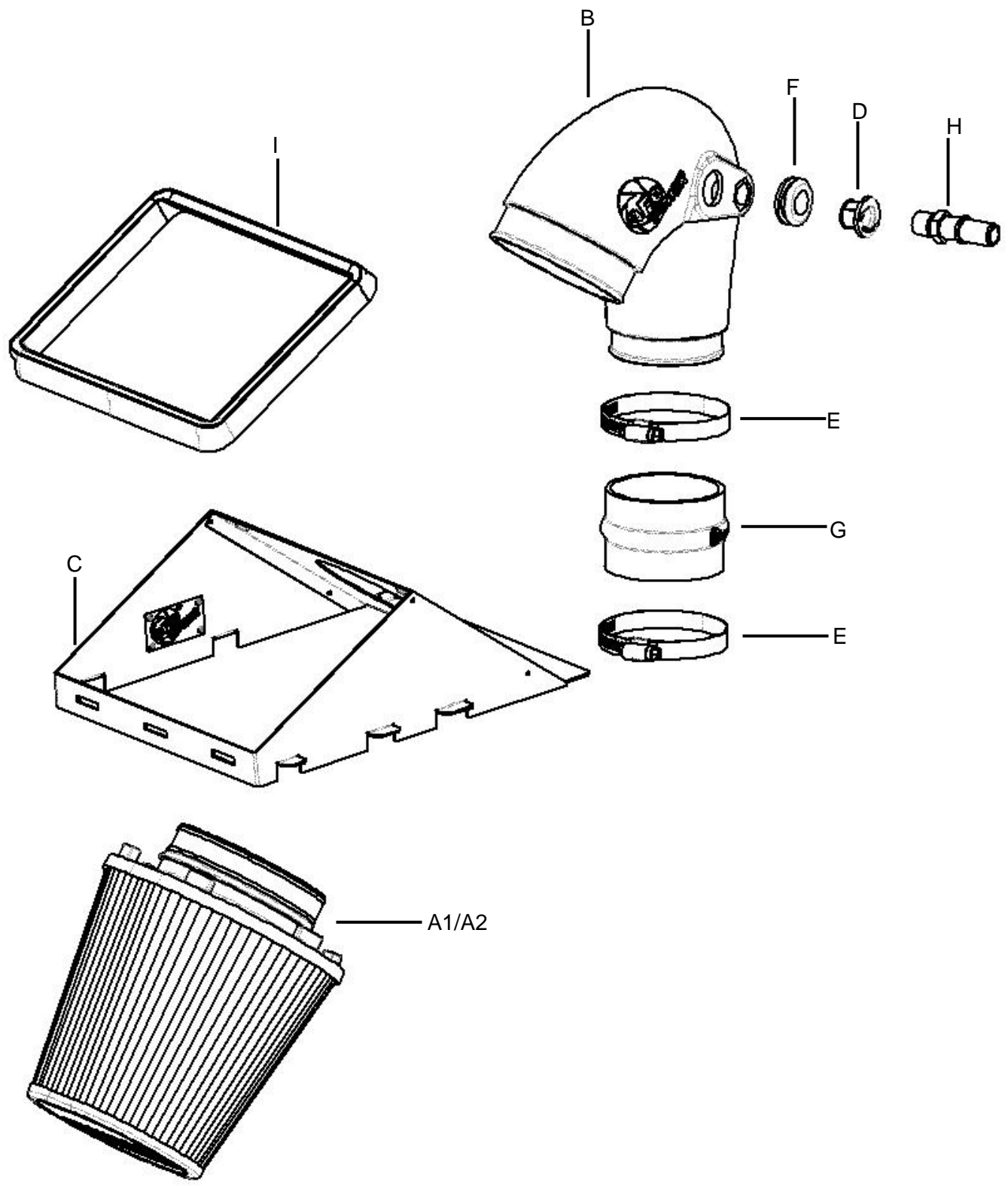

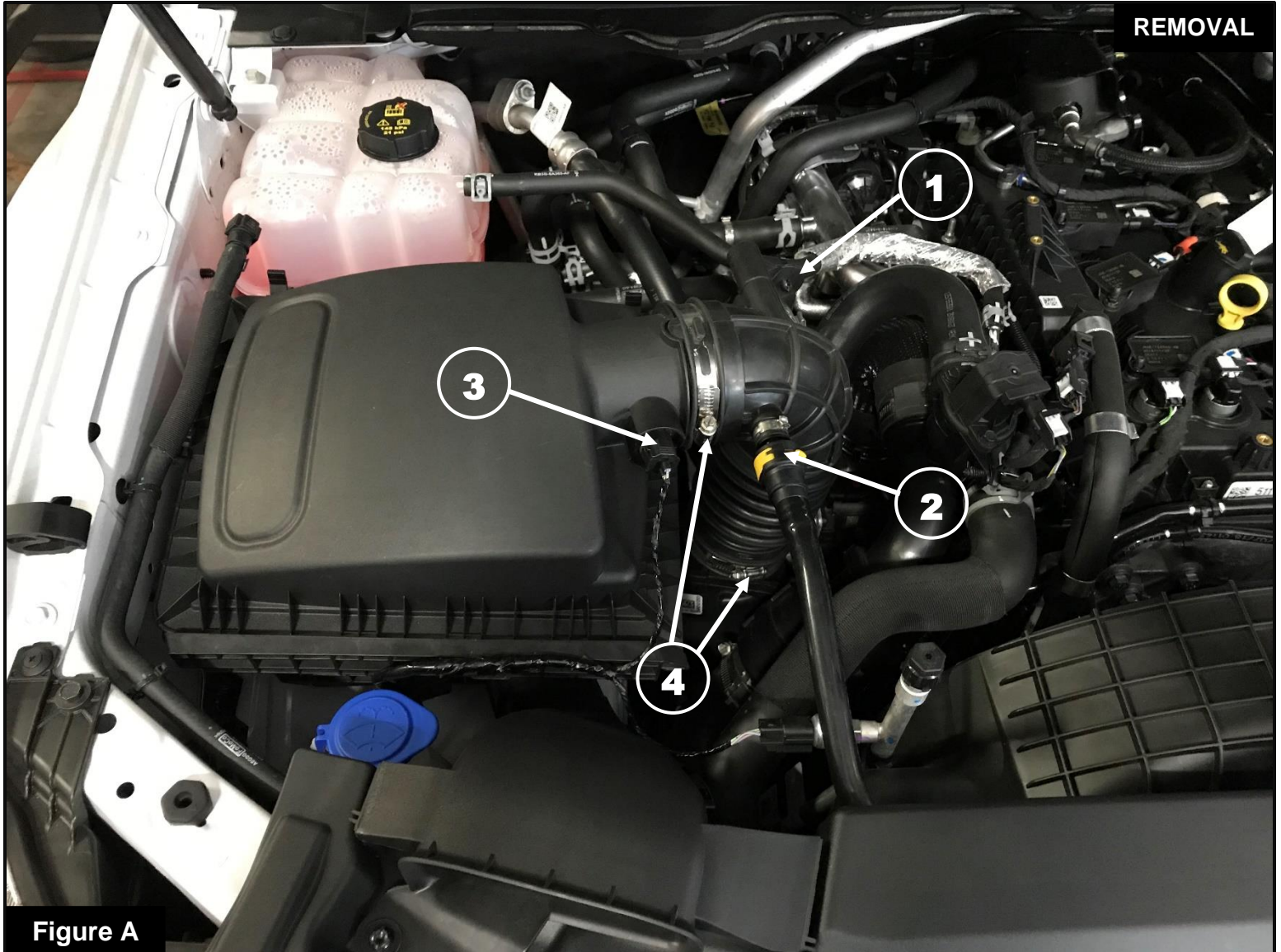

Figure A

Refer to Figure A for Steps 1-4

Step 1: Using a panel clip remover or flat head screwdriver, remove the coolant line ① attached to the factory intake tube.

Step 2: Disconnect the vent hose ② from the factory upper intake tube.

Step 3: Disconnect the air temperature sensor ③.

Step 4: Using a 7mm nut driver, loosen the clamps ④ attaching the factory upper intake tube. Remove the factory intake tube and set aside.

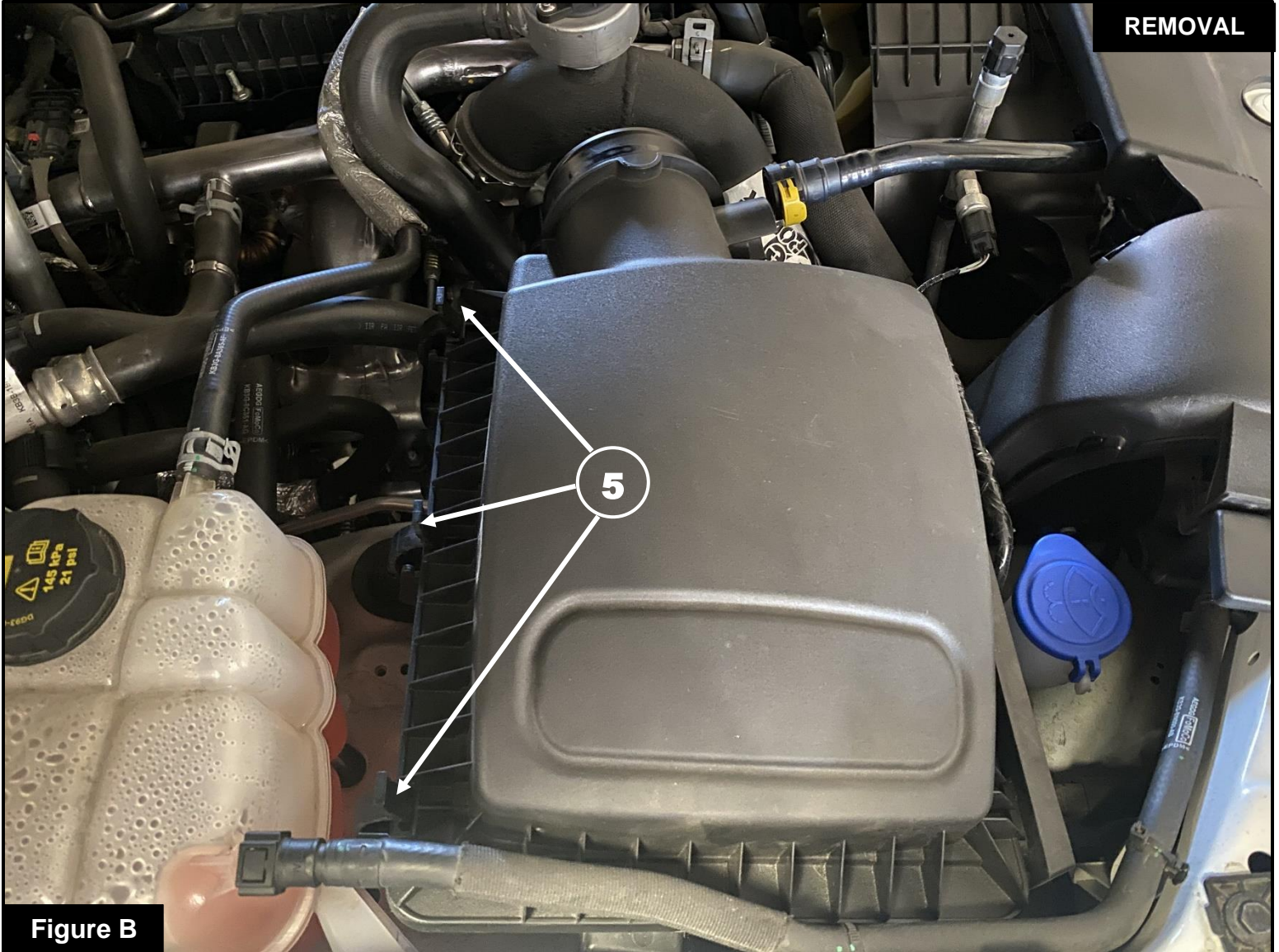
**Figure B****Refer to Figure B for Step 5**

Step 5: Release the 3 clamps (5) on the back of the factory housing and remove the factory upper housing along with the factory air filter.

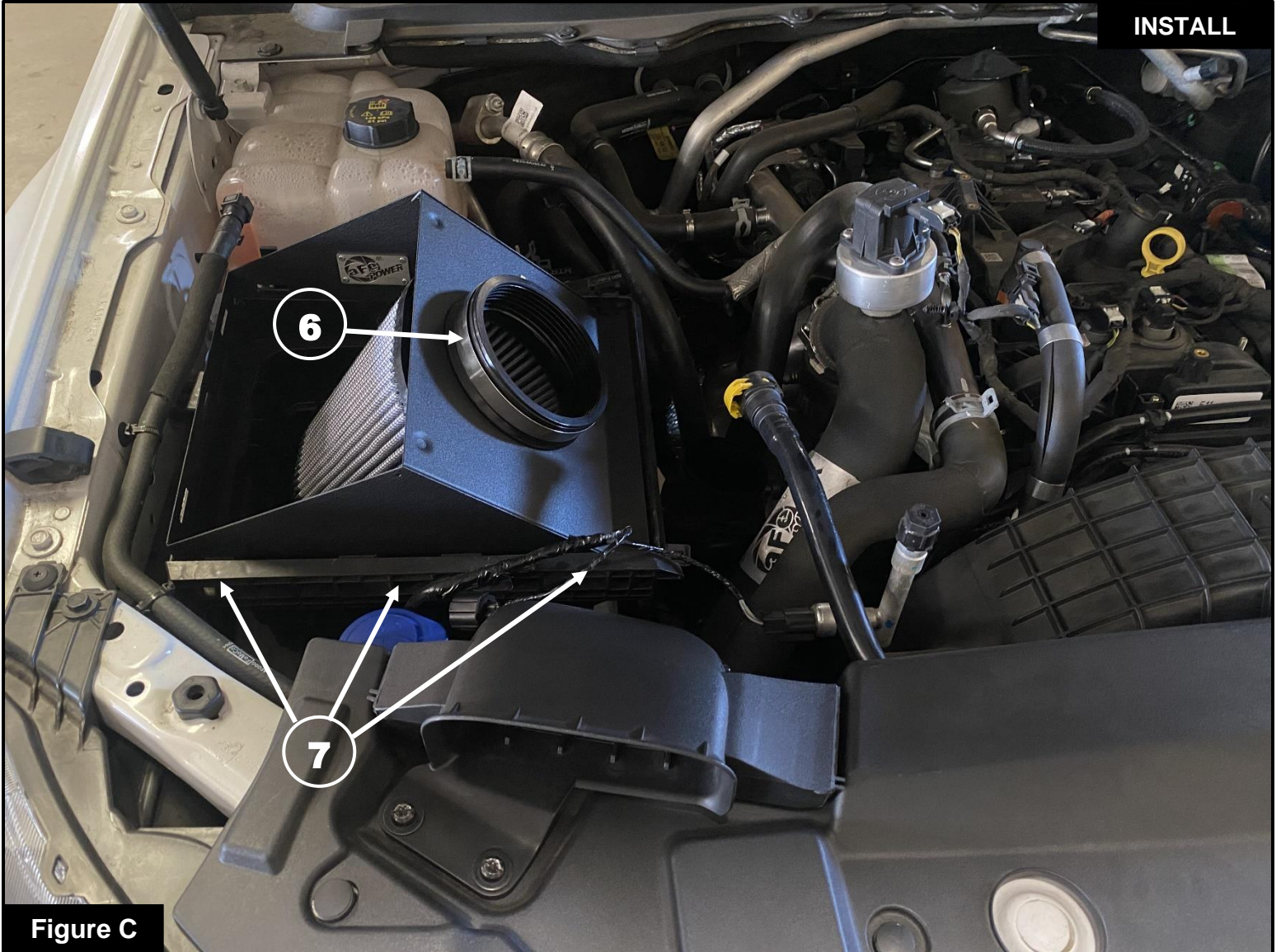
**Figure C****Refer to Figure C for Steps 6-7**

- Step 6: Remove the filter clamp (6) from the aFe POWER air filter. Slip the aFe POWER Air Filter onto the aFe POWER housing, snapping the filter in place. Place the clamp back on the filter flange.
- Step 7: Install the assembled aFe POWER air filter and housing onto the lower portion of the factory housing by sliding in the 3 tabs (7) and securing the 3 spring clips from step 5.

**Figure D****Refer to Figure D for Steps 8-9**

Step 8: Install the rubber grommet and air temp sensor fitting (8) onto your aFe POWER intake tube as shown.

***NOTE:** Use a dab of oil or dish soap on the air temp sensor fitting to help install into rubber grommet.

Step 9: Install the supplied fitting (9) onto your aFe POWER intake tube using an adjustable wrench.

***NOTE:** Exposed threads shown are normal. This is an NPT thread.

**Figure C****Refer to Figure C for Step 10**

Step 10: Remove the air intake temperature sensor ⑩ from your factory housing and set aside.

**Figure D****Refer to Figure D for Steps 11-12**

Step 11: Install the air intake temperature sensor (11) removed from step 10 onto the aFe POWER intake tube.

Step 12: Install the silicone wrapped coupling (12) onto your aFe POWER intake tube along with the supplied clamp (#048) and tighten.

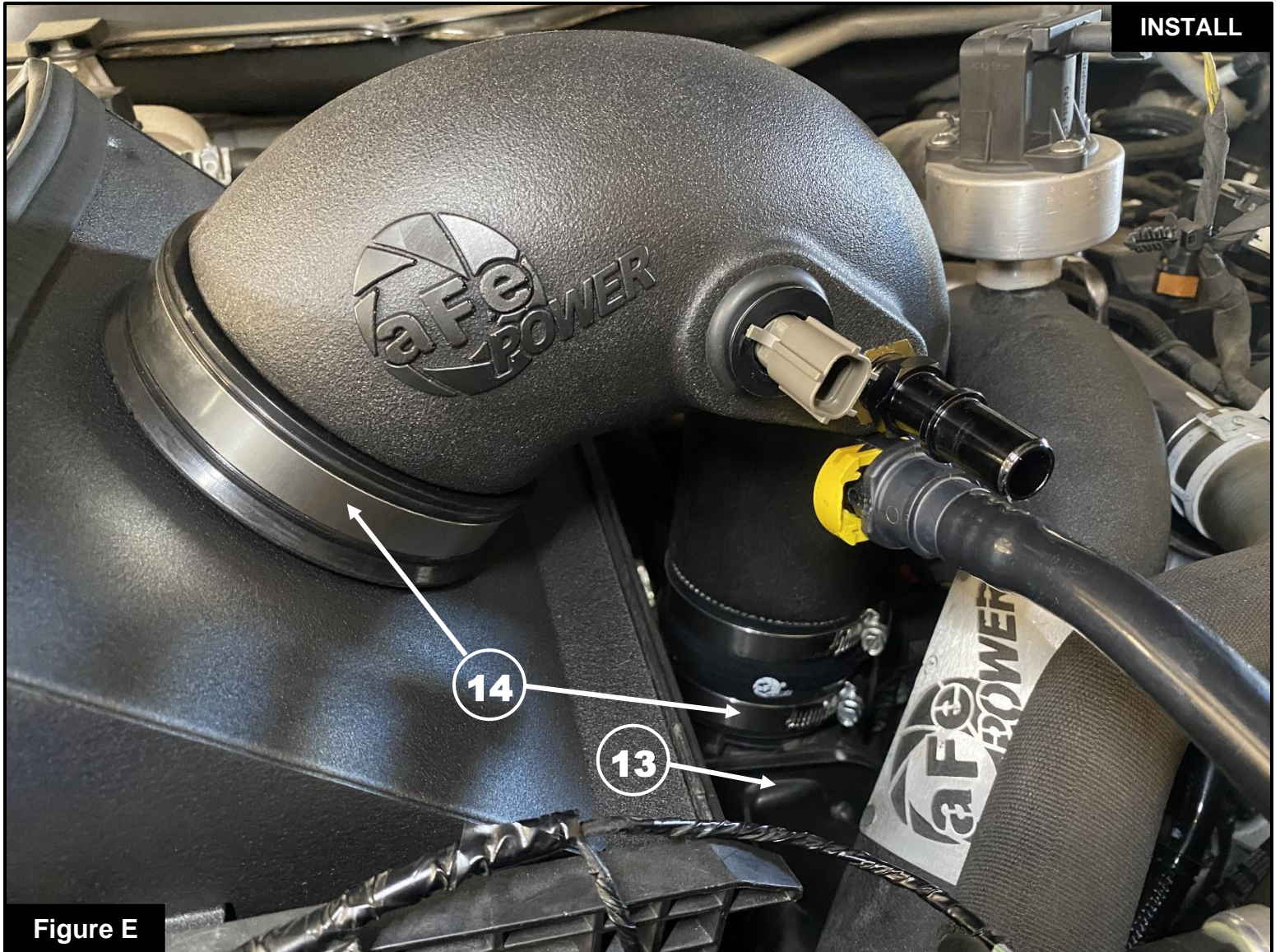
**Figure E****Refer to Figure E for Steps 13-15**

Step 13: Install the aFe POWER intake tube assembly into the vehicle beginning at the air filter.

Step 14: Slip the aFe POWER intake tube onto the turbo inlet (13) along with the clamp (#048).

Step 15: Align the aFe POWER intake tube and coupler, then tighten the clamps (14) using an 8mm nut driver.

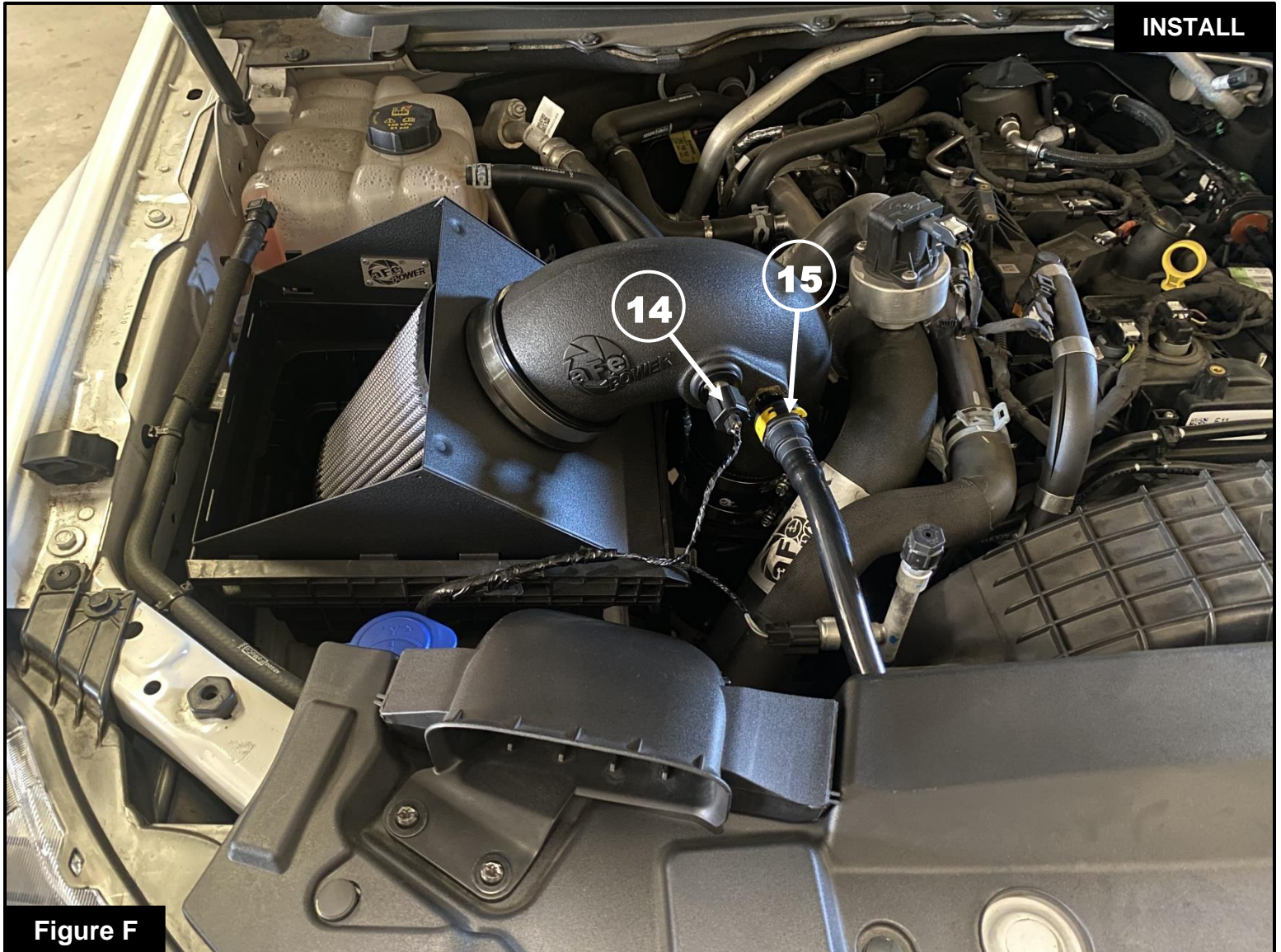

Figure F

Refer to Figure F for Steps 16-18

Step 16: Plug in the air temperature sensor (14).

Step 17: Re-connect the vent hose (15) from step 2. *(If difficult, re-connect before step 13.)

Step 18: Your installation is now complete.

NOTE: Check all screws, clamps, and connectors are secure after 100-200 miles.