

advanced FLOW engineering

Instruction Manual P/N: 51-82332 / 54-82332

Make: **Chevrolet** Model: **Silverado 1500** Year: **2014-2018** Engine: **V8-5.3L / 6.2L**

Make: **GMC** Model: **Sierra 1500** Year: **2014-2018** Engine: **V8-5.3L / 6.2L**



- Please read the entire instruction manual before proceeding.
- Ensure all components listed are present.
- If you are missing any of the components, call customer support.
- Ensure you have all necessary tools before proceeding.
- Do not attempt to work on your vehicle when the engine is hot.
- Disconnect the negative battery terminal before proceeding.
- Retain factory parts for future use.

| Label | Qty. | Description | Part Number |
|-------|------|--------------------------------------|-------------|
| A1 | 1 | Pro DRY S Air Filter | 21-91105 |
| A2 | 1 | Pro 5R Air Filter | 24-91105 |
| B | 1 | Housing | 05-82322B2 |
| C | 1 | Tube | 05-82332B1 |
| D | 1 | Coupling, Hump | 05-01264 |
| E | 2 | Clamp #060 | 03-50002 |
| F | 1 | Hose, Breather: 1/2" (13" Inches) | 05-01396 |
| G | 1 | Hose, Breather: 1/2" (16" Inches) | 05-01396 |
| H | 1 | Seal Trim 7/16" (27" Inches) | 05-00072 |
| I | 2 | Screws, Torx M4 | 03-50491 |
| J | 1 | Plug | 05-01361 |
| K | 1 | Coupling Reducer 3-1/2" to 3-3/4" ID | 05-01203 |

Installation will require the following tools:

8mm Nut driver, 11mm Nut driver, T15 & T20 torx bit or driver.

Note: Legal in California for use on race vehicles only. The use of this device on vehicles used on public streets or highways is strictly prohibited in California and others states that have adopted California emission regulations.

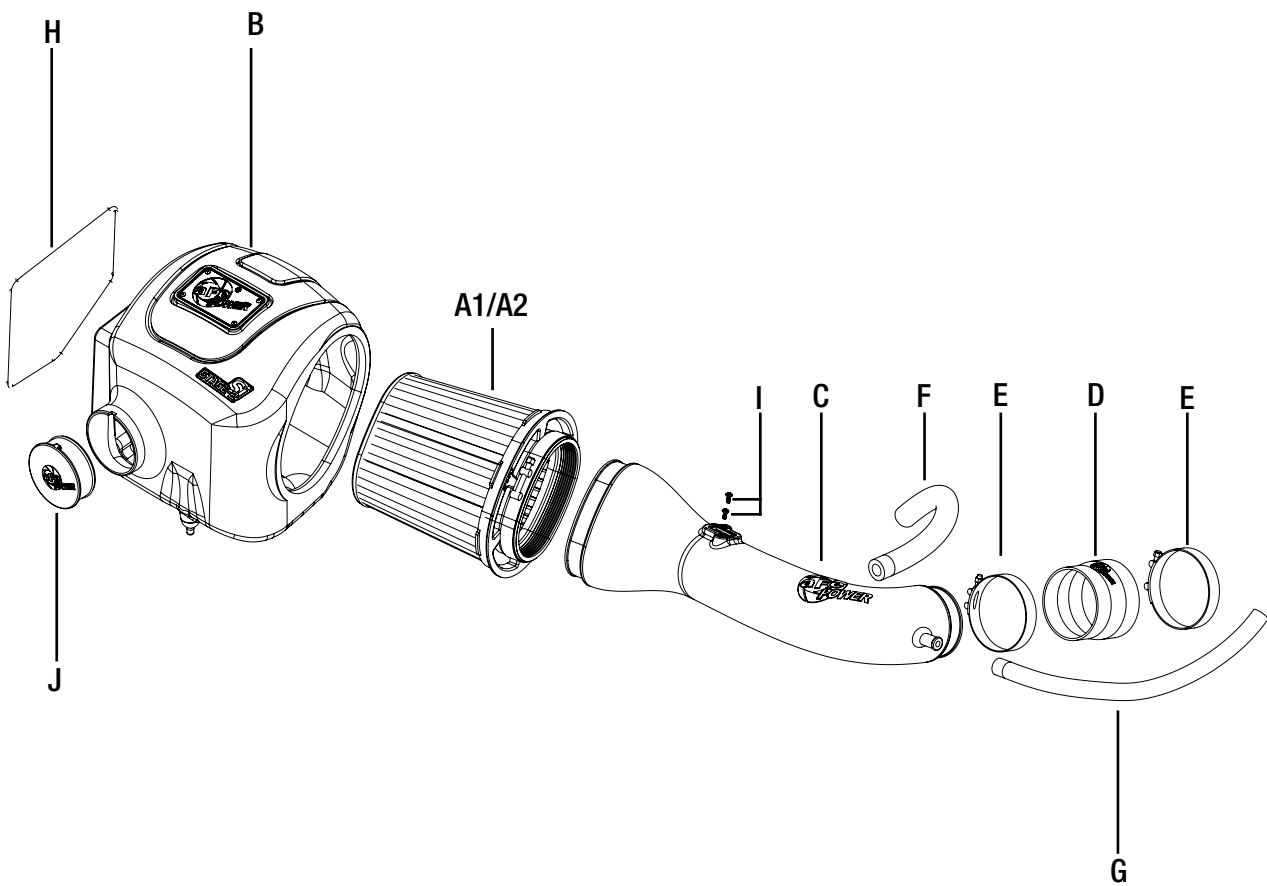

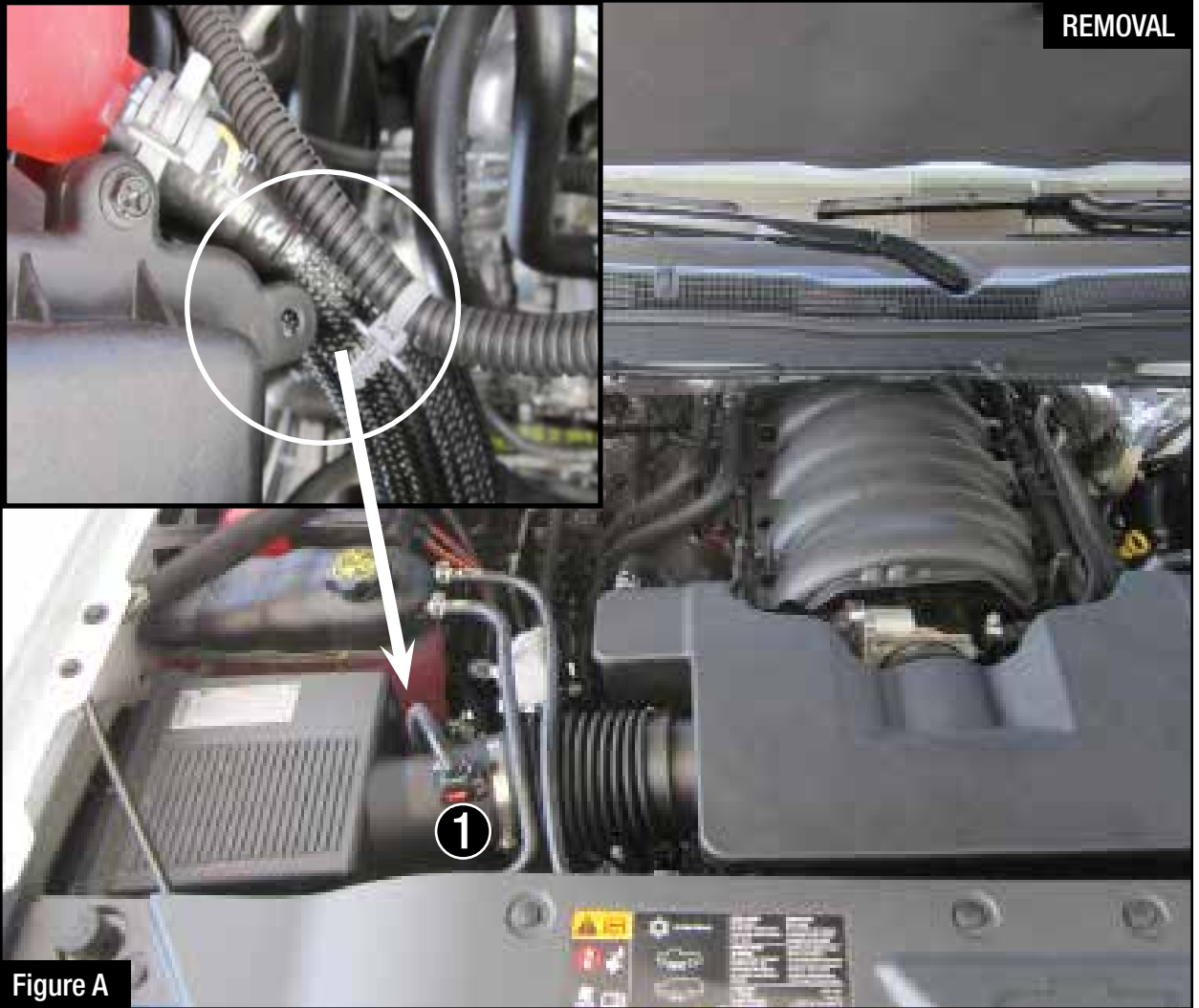

Refer to Figure A for Steps 1-2

Step 1: Disconnect the MAF sensor plug. ①

Step 2: Disconnect the MAF sensor harness clip from the OE airbox.



Figure B

Refer to Figure B for Step 3

Step 3: Loosen the clamps②at the airbox and at the throttle body.



Refer to Figure C for Steps 4-5

Step 4: Disconnect the OE crankcase breathers from the valve covers (as shown) on both sides of the engine.

Step 5: Carefully remove the entire intake tube plenum ③ with the crankcase breather plugs attached.

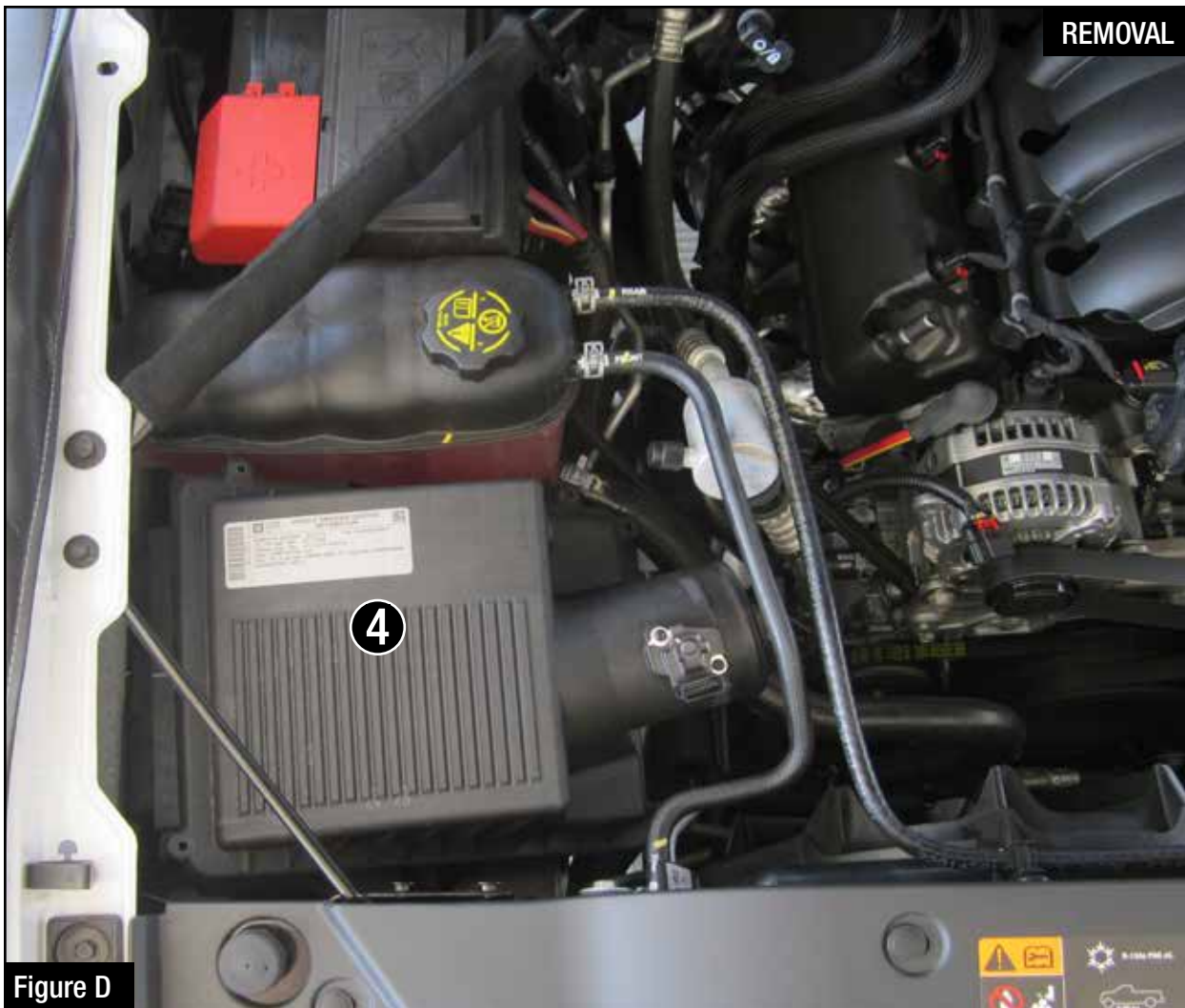
**Figure D****Refer to Figure D for Step 6**

Step 6: Remove the factory airbox out of the vehicle (4). (Use an upward pull to release the retaining plug)



Figure E

Refer to Figure E for Step 7

Step 7: Slide the aFe filter and clamp (5) into the aFe airbox and push it in until it locks into place.
Do not tighten the clamps at this time.

NOTE: Use the supplied plug (6) to close the auxiliary air inlet if you want to completely seal the airbox.

**Figure F****Refer to Figure F for Steps 8-9**

Step 8: Remove the retaining plug (7) from the bottom of the factory airbox and transfer it to the aFe airbox.

Step 9: Install the trim seal on the inlet of the aFe airbox (8).



Figure G

Refer to Figure G for Step 10

Step 10: Install the aFe airbox assembly into the vehicle. Firmly push it into the factory mounting grommets.



Figure H

Refer to Figure H for Steps 11-12

Step 11: Remove the MAF sensor with gasket (9) from the factory airbox using a T15 Torx drive.

Step 12: Install the MAF sensor with gasket into the aFe intake tube using the supplied M4 screws and a T20 Torx drive.

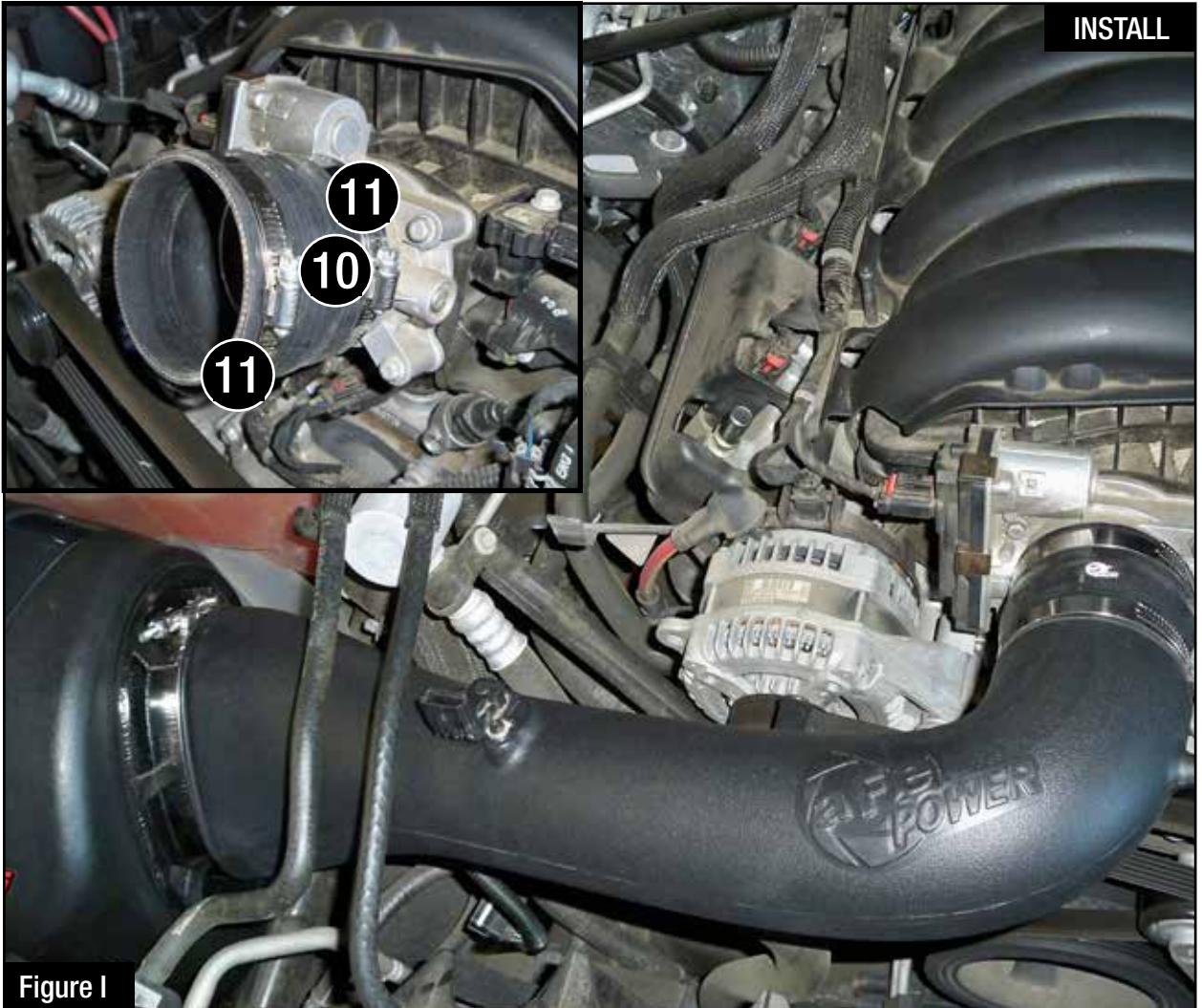

Figure I

Refer to Figure I for Steps 13-15

Step 13: For V8-5.3L, install the supplied hump coupler (10) on the throttle body and slide on the two supplied clamps. (11)

For V8-6.2L, install the supplied reducer coupler instead of the hump coupler. Do not tighten at this time.

Step 14: Slide the intake tube into the filter and then into the coupler.

Step 15: Align the intake tube correctly then tighten all clamps.



Figure J

Refer to Figure J for Steps 16-18

Step 16: Install the two supplied crankcase breather hoses (12) between the valve cover and the aFe tube on both passenger and driver side. (Make sure hoses are secure over the bead).

Step 17: Reconnect the MAF sensor harness (13).

Step 18: Make sure all clamps and connections are secured. Your installation is now complete!

Thank you for choosing aFe Power.

NOTE: Check all bolts, clamps, and connectors after 200 miles.



Pro DRY S Air Filter



P/N: 21-91105

Pro 5R Air Filter



P/N: 24-91105

Pro DRY S Restore Kit



P/N: 90-59999

Blue Squeeze Restore Kit



P/N: 90-50501

Blue Aerosol Restore Kit



P/N: 90-50001

Rebel Series Exhaust



P/N: 49-44062-B (Blk. Tips)
49-44062-P (Pol. Tips)
(V8-5.3L)

Cat-Back Exhaust



P/N: 49-44072-B (Blk. Tip)
49-44072-P (Pol. Tip)
(V8-5.3L)

Dual Cat-Back Exhaust



P/N: 49-44071-B (Blk. Tip)
49-44071-P (Pol. Tip)
(V8-5.3L)

Sprint Booster V3.



P/N: 77-14003

Throttle Body Spacer



P/N: 46-34008 (V8-5.3L)

5.3L Long Tube Headers



P/N: 48-44005-YC (Street)
48-44005-YN (Race)

Sway-A-Way Coilovers



P/N: 501-5600-01