

advanced FLOW engineering

Instruction Manual P/N: 51-81932/54-81932/75-81932

Make: **Toyota** Model: **FJ Cruiser/ 4Runner/ Prado** Year: **2010-2015** Engine: **V6-4.0L**



- Please read the entire instruction manual before proceeding.
- Ensure all components listed are present.
- If you are missing any of the components, call customer support.
- Ensure you have all necessary tools before proceeding.
- Do not attempt to work on your vehicle when the engine is hot.
- Disconnect the negative battery terminal before proceeding.
- Retain factory parts for future use.

Label	Qty.	Description	Part Number
A1	1	Pro DRY S Air Filter	21-90044 (Gray Media) Included in kit 51/54-81932
A2	1	Pro 5R Air Filter	24-91021 (Blue Media) Included in kit 54-81932
A3	1	Pro GUARD 7 Air Filter	72-90044 (Gold Media) Included in kit 75-81932
B	1	Housing	05-00823
C	1	Tube	05-81932B1
D	1	Injection Molded Adaptor	05-00611
E	1	Plug	05-00937
F	1	Cover	05C00823B
G	1	Coupling, Silicone Hump	05-01399
H	1	Coupling, Silicone Reducer	05-01400
I	1	Trim Seal - 17"	05-00789
J	2	#72 Clamp	03-50010
K	2	#48 Clamp	03-50007
L	1	Isolation Mount	03-50063
M	1	MAS Gasket	05-00762
N	2	Nylon Spacer	03-50090
O	1	Brass Hose nipple	03-50191
P	2	Flat Head Screws 8-32x5/8	03-50030
Q	6	Small Button Head Screw	03-50113
R	2	Hex Nut	03-50087
S	2	Flat Washer	03-50065
T	3	Large Button Head Screws	03-50102

Note: Legal in California for use on race vehicles only. The use of this device on vehicles used on public streets or highways is strictly prohibited in California and others states that have adopted California emission regulations.

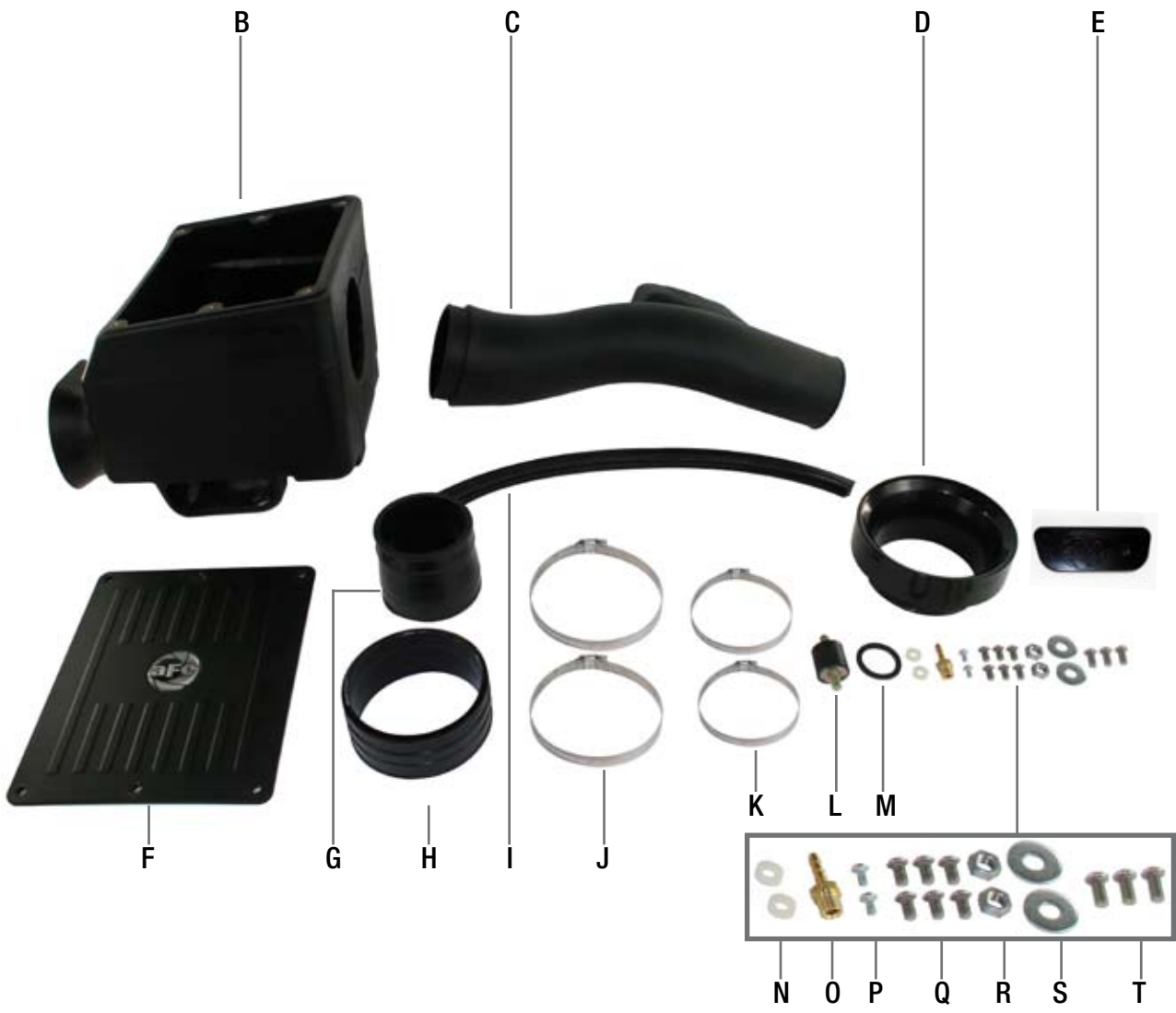



Figure A

Refer to Figure A for steps 1 - 3

Step 1. Complete stock intake

Step 2. Lift up on the front of the engine cover (1) and pull straight out to remove.

Step 3. Unplug the MAF sensor and wire harness (2) from the stock intake cover.

**Figure B****Refer to Figure B for steps 4-7**

Step 4. Using a 10mm nut driver, unscrew the hose clamp (3) at the airbox.

Step 5. Unclip the 4 clips (4) on the airbox and remove the airbox top.

Step 6. Pull out the OE air filter.

Step 7. Using a 12mm socket, ratchet and extension, remove the 3 bolts (5) that secure the bottom of the stock airbox to the vehicle.



Figure C

Refer to Figure C for steps 8-9

Step 8. Remove airbox from vehicle.

Step 9. Disconnect the Crank Case Vent (CCV) hose (6) from the intake tube by sliding back the spring clamp and pulling the hose off.



Figure D

Refer to Figure D for steps 10 -12

- Step 10. Remove the vacuum line (7) from the intake plenum by twisting and pulling it off at the same time.
- Step 11. Using a 10mm nut driver loosen the hose clamp (8) at the throttle body.
- Step 12. Use a 10mm socket and a ratchet to remove the bolt (9) that secures the intake tube bracket to the engine



Figure E

Refer to Figure E for step 13

Step 13. Remove the stock intake tube from the vehicle and prepare to install your new aFe Power intake.



Figure F

Refer to Figure F for steps 14-15

Step 14. Remove two of the isolation mounts from the stock intake housing by pushing the metal sleeve out and then removing the rubber grommet from the housing.

Step 15. Insert the rubber grommets into the two large holes in the bottom of the aFe housing and then push the metal sleeves into the grommets.

**Figure G****Refer to Figure G for step 16**

Step 16. Install the aFe 3-angle adaptor into the aFe housing. Use 3 of the large button-head Allen screws and a 4mm Allen wrench to fasten the adaptor to the housing.



Figure H

Refer to Figure H for step 17

Step 17. Install the trim seal on the air inlet port of the housing. Make sure the trim seal is pushed all the way onto the plastic to ensure an accurate fit in the vehicle.



Figure I

Refer to Figure G for steps 18-19

Step 18. Install a nut and a washer to one side of the isolation mount as shown.

Step 19. Install the isolation mount assembly into the vehicle in the location shown.



Figure J

Refer to Figure H for steps 20-21

Step 20. Install the housing into the vehicle and secure it using two of the stock air box bolts. Use an M8 washer and nut to fasten the housing to the new isolation mount.

Step 21. Tighten the M8 nut with a 13mm socket, a ratchet and an extension. Use the 12mm socket and an extension to tighten the two stock bolts.

Note: If your vehicle has factory horns that are mounted in the way of the new aFe housing, then you will need to relocate them. This can be done by flipping the bracket around and mounting the horn in the pre-tapped hole closer to the firewall.

Figure K

Refer to Figure G for steps 22-24

Step 22. Install the brass nipple (03-50191) onto the tube using a ½” open-end wrench.

Step 23. Remove the MAF sensor from the stock intake cover using a #1 Phillips screwdriver.

Step 24. Install the MAF gasket (05-00118) onto the tube by removing the white paper off of the backside of the gasket and applying the sticky side of the gasket towards the tube. Use the spacers and the screws provided to fasten the MAF sensor to the aFe intake tube.



Figure L

Refer to Figure H for steps 25-30

Step 25. Install large coupling (05-00421) onto 3-angle adaptor using two 72mm clamps. (Do Not Tighten)

Step 26. Install small coupling (05-00815) over the throttle body using two 48mm clamps. (Do Not Tighten)

Step 27. Install intake tube as shown. (Insert tube into large coupling first. Tilt small coupling upward and drop the tube down. Adjust the tube between couplings for best clamp engagement)

Step 28. Connect CCV hose (10) to the intake tube using the spring clamp.

Step 29. Connect the vacuum line (11) to the brass fitting by twisting the hose, pushing at the same time.

Step 30. Re-connect the MAF (12) sensor wire harness.

Figure M

Refer to Figure G for steps 31-32

Step 31. If your kit came with an aFePower Pre-Filter, install the Pre-Filter prior to installing the filter.

Step 32. Install the filter into the 3-angle adaptor and slide it all the way to the back wall of the housing. Tighten the hose clamp using a 8mm nut driver.

**Figure N****Refer to Figure H for steps 33-36**

Step 33. Install the aFe intake cover onto the air box using six of the small button-head Allen screws. Tighten the screws with a 4mm Allen wrench.

Step 34. Tighten all of the remaining hose clamps with a 8mm nut driver.

Step 35. Reinstall the engine cover by clipping in the backside of the cover and then pushing the front of the cover straight down.

Step 36. The installation is now complete!

NOTE: Retighten all connections after approximately 100-200 miles.



Pro DRY S Air Filter



P/N: 21-90044

Pro 5R Air Filter



P/N: 24-91021

Pro GUARD 7 Air Filter



P/N: 72-90044

Pro DRY S Restore Kit



P/N: 90-59999

Gold Aerosol Restore Kit



P/N: 90-50000

Blue Aerosol Restore Kit



P/N: 90-50001

Gold Squeeze Restore Kit



P/N: 90-50500

Blue Squeeze Restore Kit



P/N: 90-50501

aFe Power Hat



P/N: 40-10083

Warranty

General Terms:

- aFe warrants their products to be free from manufacturer's defects due to workmanship and material.
- This warranty applies only to the original purchaser of the product and is non-transferrable.
- Proof of purchase of the aFe product is required for all warranty claims.
- Warranty is valid provided aFe instructions for installation and/or cleaning were properly followed.
- Proper maintenance with regular inspections of product is required to insure warranty coverage.
- Damage due to improper installation, abuse, unauthorized repair or alteration is not warranted.
- Incidental or consequential damages or cost, including installation and removal of part, incurred due to failure of aFe product is not covered under this warranty.
- All warranty is limited to the repair and/or replacement of the aFe part. To request Return Goods Authorization ("RGA"). Upon receipt of the RGA, you must return the product to the address provided in the RGA, freight prepaid and accompanied with a dated proof of purchase and the RGA. Upon receipt of the defective product and upon verification of proof of purchase, aFe will either repair or replace the defective product within a reasonable time, not to exceed thirty days.

Product Category	P/N Prefix	Warranty duration
Direct OE Replacement Filters	10, 11, 30, 31, 71, 73	Life of the vehicle
Racing Filters	18	1 year
Universal	21, 24, 72	2 years
Air Intake Systems	50, 51, 54, 55, 75	2 years
Exhaust Systems	49	2 years
Intercoolers & Intercooler Tubes	46-2	2 years
Intake Manifolds	46-1	2 years
Differential Cover	46-7	Life of the vehicle
Exhaust Manifolds	46	2 years
Throttle Body Spacers	46-3	2 years
Fluid Filters	44	90 days
Pre-Filters	28	2 years
Heavy Duty OE Replacement	70	2 years
PowerSports OE Replacement	81, 87	2 years
PowerSports Intake Systems	85	2 years

No other warranty expressed or implied applies nor is any person or advanced FLOW engineering authorized to assume any other warranty. Some States do not allow the exclusion or limitation of incidental or consequential damages or do not allow limitations on how long an implied warranty lasts, so the above limitations or exclusions may not apply to you. This warranty gives you specific legal rights, and you may also have other rights which vary from State to State.

Buy quality performance air intake systems in our online store.