

advanced FLOW engineering Magnum FORCE Stage-2 Si Cold Air Intake System

Instruction Manual P/N: 51-80072-1 / 54-80072-1

Make: **Dodge** Model: **RAM 2500/3500** Year: **1994-2002** Engine: **L6-5.9L (td) Cummins**



- Please read the entire instruction manual before proceeding.
- Ensure all components listed are present.
- If you are missing any of the components.
- Ensure you have all necessary tools before proceeding.
- Do not attempt to work on your vehicle when the engine is hot.
- Disconnect the negative battery terminal before proceeding.
- Retain factory parts for future use.

Label	Qty.	Description	Part Number
A1	1	Air Filter (Pro 5R)	24-91092
A2	1	Air Filter (Pro DRY S)	21-91092
B	1	Housing	05-80072B1
C	1	Tube	05-80072B2
D	2	Clamp, #064	03-50006
E	1	Coupling, Silicone Hump	05-01332

Installation will require the following tools:

Flat head screwdriver, 8mm nut driver, 11mm nut driver and panel popper (Recommended).

Emissions Disclaimer:

This product is not currently CARB exempt and is not available for purchase in California or for use on any vehicle registered with the California Department of Motor Vehicles.

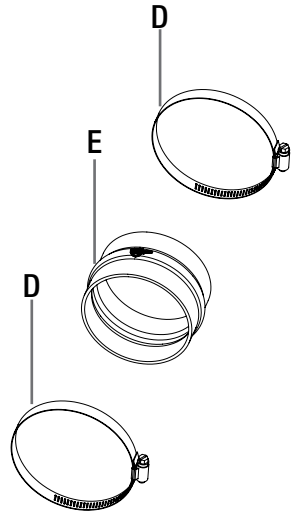
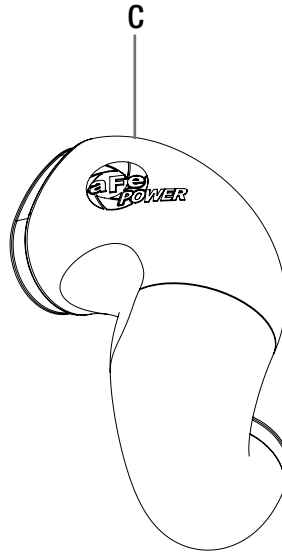
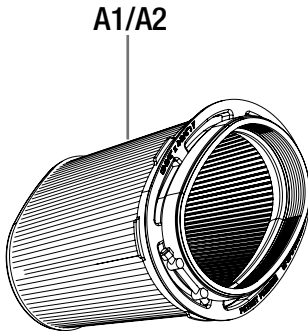
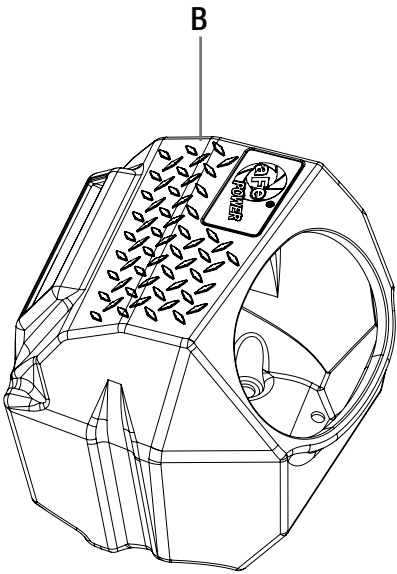

**Figure A****Refer to Figure A for Step 1**

Step 1: Use an 8mm nut driver to loosen the factory clamps (1) at the turbo and the airbox. Remove the factory intake tube (2).



Figure B

Refer to Figure B for Step 2

Step 2: Un-clip the upper half of the airbox and remove upper half and air filter.



Figure C

Refer to Figure C for Step 3

Step 3: Remove the lower half of the airbox (3) by pulling up to release airbox from its mounting grommets (4).



Figure D

Refer to Figure D for Step 4

Step 4: Make sure plastic inserts (5) are still on the mounting pins. If they pulled out and are stuck in the lower half of the airbox grommet, remove them and insert them back on the mounting pins. Remove the plastic air duct (6) that goes through the fender if equipped.

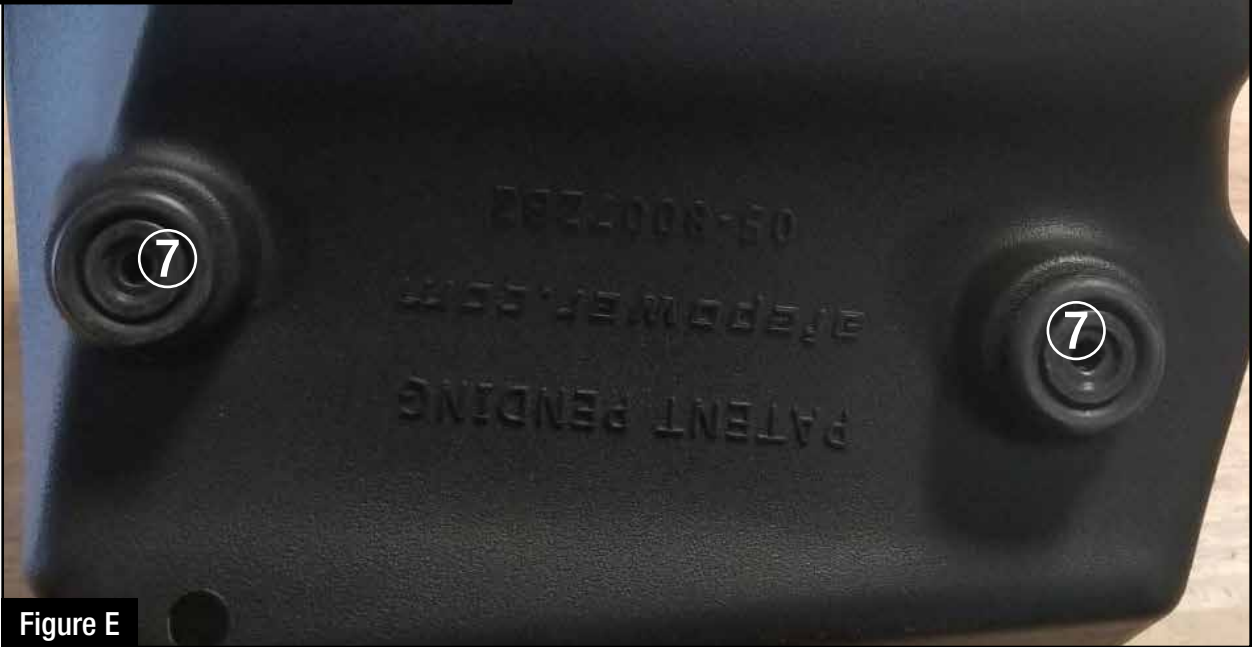

Figure E

Refer to Figure E for Step 5

Step 5: Remove all three (x3) grommets (7) from the lower half of the airbox and install them onto the aFe POWER airbox.



Figure F

Refer to Figure F for Step 6

Step 6: Install the supplied coupling (8) and one of the supplied clamps (9) onto the turbo inlet and fully tighten the clamp with an 8mm nut driver.



Figure G

Refer to Figure G for Step 7

Step 7: Install the aFe POWER airbox (10) into the vehicle. Aligning the three (x3) grommets to their respective studs may take a few attempts.

**Figure H****Refer to Figure H for Steps 8-9**

Step 8: Re-install the plastic scoop you removed earlier by inserting it into the opening on the inside of the aFe POWER airbox (11).

Step 9: Ensure the scoop (12) is properly seated into the vehicle.

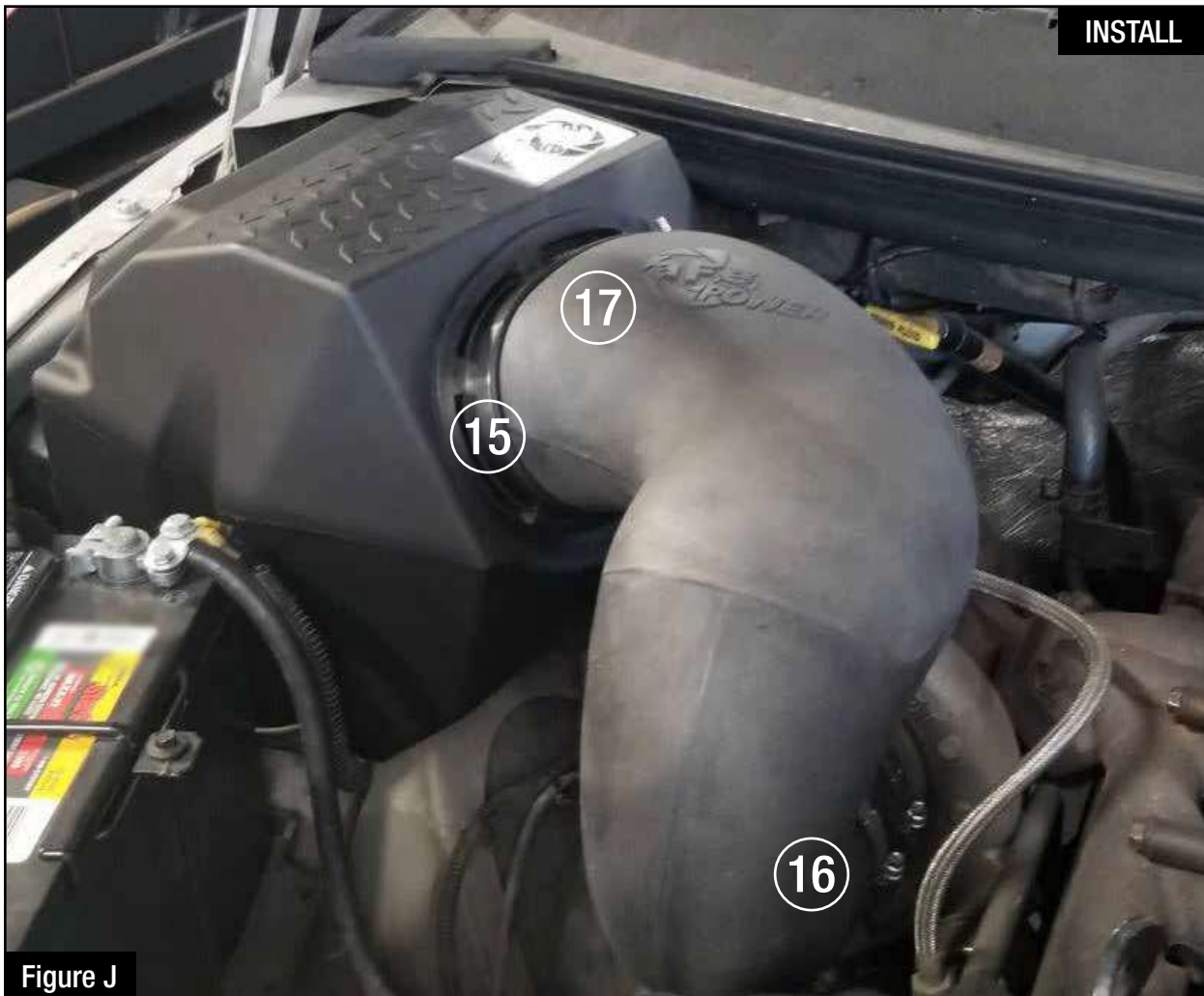

Figure I

Refer to Figure I for Steps 10-11

Step 10: Install the filter ⑬ into the aFe POWER airbox.

Step 11: Install the other supplied clamp ⑭ onto the end of the coupling, but DO NOT tighten.

**Figure J****Refer to Figure J for Steps 12-13**

Step 12: Install the supplied T-Bolt clamp (15) onto the filter flange.

Step 13: Slip the smaller end of the aFe POWER intake tube (16) into the coupling and swing it over to install it into the filter (17). Tighten the T-bolt clamp with an 11mm nut driver.

**Figure K****Refer to Figure K for Step 14**

Step 14: Ensure all parts are seated correctly and tighten down the supplied clamp (18) on the tube. Double check that all components are tight and secure. Your installation is now complete. Thank you for choosing aFe POWER!

NOTE: Retighten all connections after approximately 100-200 miles.



Pro DRY S Air Filter



P/N: 21-91092

Pro 5R Air Filter



P/N: 24-91092

Blue Squeeze Restore Kit



P/N: 90-50501

Pro DRY S Restore Kit



P/N: 90-59999

Intercooler Tubes



P/N: 46-20064-B

Exhaust Manifold



P/N: 46-32019 (For T3)
46-32020 (For T4)

DFS780 PRO Fuel System



P/N: 77-22011

Turbocharger



P/N: 46-60110 (Street)
46-60062-1 (GT Series)

TB-Back Exhaust System



P/N: 49-02033 (No Tip)
49-42033-B (Blk. Tip)
49-42033-P (Pol. Tip)

Transmission Pan Cover



P/N: 46-70052

Intercooler Kit



P/N: 46-21062-B (Blk I/C)
46-20062

Differential Cover w/ Oil



P/N: 46-70032-WL (w/ Oil)
46-70032 (Blk./Mach)

Check out the collection of performance air intake systems we offer.