

GT
MOMENTUM™

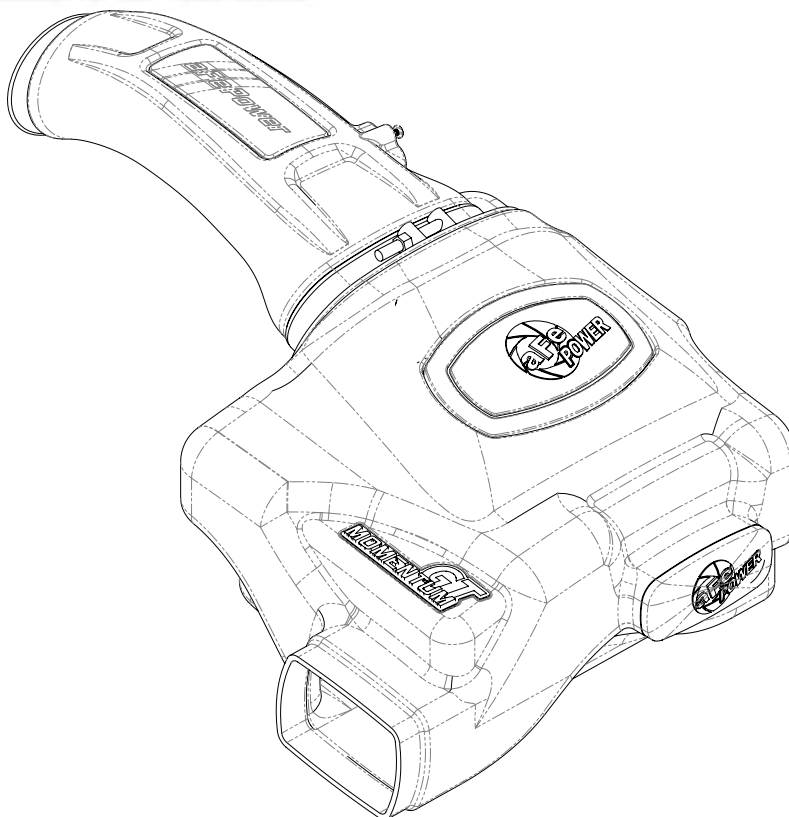

advanced FLOW engineering

Instruction Manual P/N: 51-76313 / 54-76313

Make: **BMW** Model: **335i/xi (E90/E92/E93)** Year: **2011-2013** Engine: **L6-3.0L (t) N55**
Make: **BMW** Model: **135i (E82/E88)** Year: **2011-2013** Engine: **L6-3.0L (t) N55**
Make: **BMW** Model: **X1 35ix (E84)** Year: **2011-2015** Engine: **L6-3.0L (t) N55**



- Please read the entire instruction manual before proceeding.
- Ensure all components listed are present.
- Ensure you have all necessary tools before proceeding.
- Do not attempt to work on your vehicle when the engine is hot.
- Disconnect both the negative battery terminal before proceeding.

Retain factory parts for future use.

Label	Qty.	Description	Part Number
A1	1	Air Filter (Pro DRY S)	21-90089
A2	1	Air Filter (Pro 5R)	24-90089
B	1	Housing	05-76313B2
C	1	Tube	05-76313B1
D	2	Screw, Torx: M4	03-50490
E	1	Plug, Urethane	05-01225

Installation will require the following tools:

6mm nut driver, 11mm nut driver or deep socket, 7mm nut driver or socket, socket driver, T20 Torx bit, T25 Torx bit and bit driver.

Note: Legal in California for use on race vehicles only. The use of this device on vehicles used on public streets or highways is strictly prohibited in California and others states that have adopted California emission regulations.

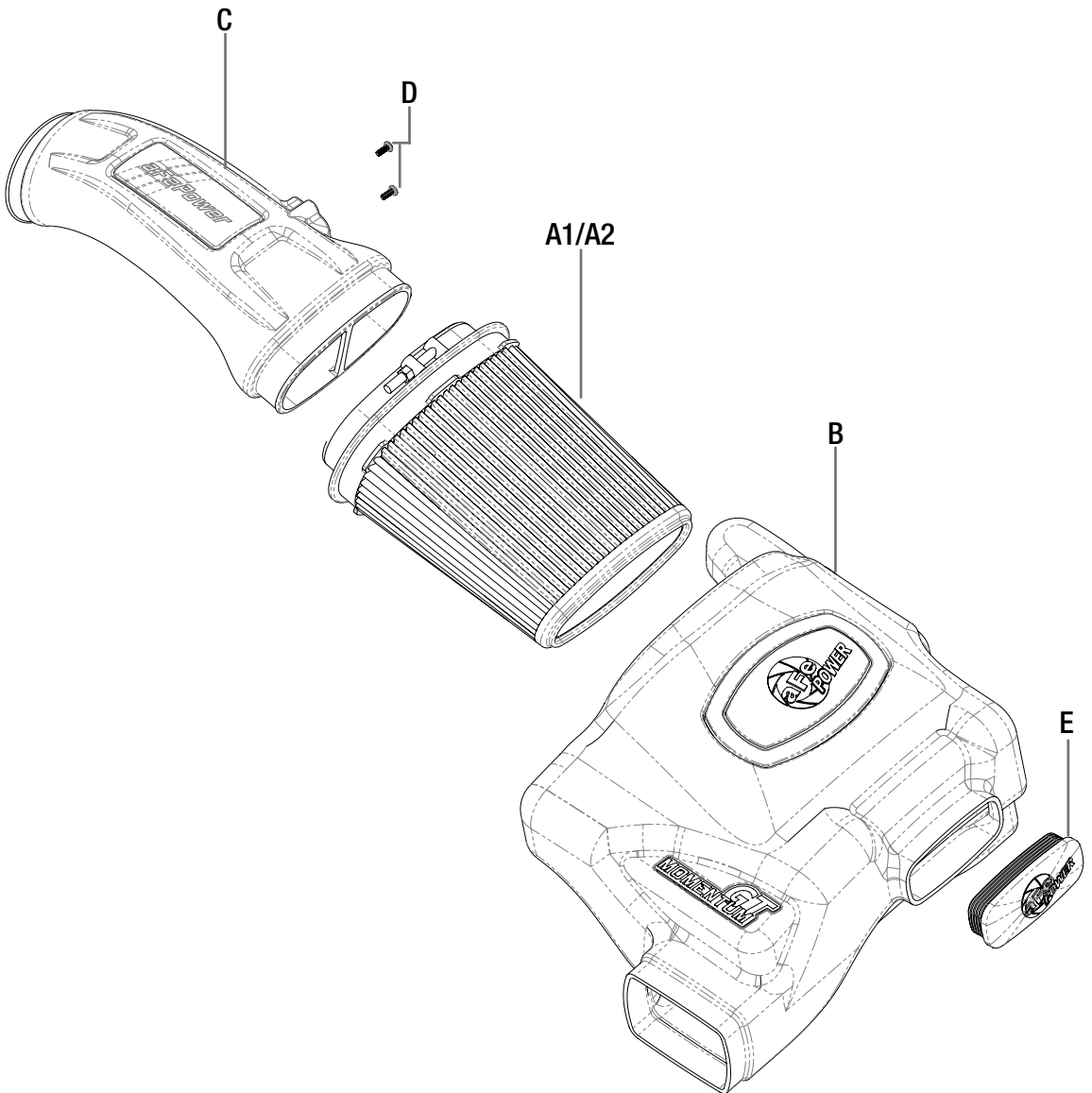



Figure A
Refer to Figure A for Steps 1-4

Step 1: Use a 6mm nut driver to loosen the clamp on the flexible intake coupler that is closest to the Mass Air Flow (MAF) sensor. ①

Step 2: Unclip the (4) clips on the intake cover and be careful not to let them fall out. ②

Step 3: Disconnect the MAF sensor harness from the sensor. ③

Step 4: Remove the top half of the OE air intake which consists of the tube and cover. Leave the flexible intake coupler and clamp in place.

**Figure B****Refer to Figure B for Steps 5-8**

Step 5: Remove the OE air filter from the airbox.

Step 6: Disconnect the (3) wires from the metal bracket located on the back of the airbox. ④

Step 7: Lift up on the airbox to remove it from the (3) mounting posts.

Step 8: Detach the air box from the air duct as you remove the airbox from the vehicle.

**Figure C****Refer to Figure C for Steps 9-10**

Step 9: Remove the (3) grommets from the bottom of the OE airbox and transfer them to the corresponding locations on the new aFe airbox.

Step 10: Remove the metal bracket from the back of the OE airbox using a 7mm socket and driver, and reattach the bracket to the back of the aFe housing using the OE screws.

**Figure D****Refer to Figure D for Steps 11-12**

Step 11: Remove the MAF sensor from the OE intake tube using a T25 Torx driver, and install the MAF sensor into the aFe intake tube in the same orientation.

Step 12: Use the new M4 screws provided and a T20 Torx driver to secure the MAF sensor to the aFe intake tube.

**Figure E****Refer to Figure E for Steps 13-15**

- Step 13: Install the new aFe housing into the vehicle and align it with the air duct before securing it to the grommets. Make sure the bracket is on the correct side of the (3) wires in the back before securing the airbox. To secure the airbox, press down firmly on the airbox in the (3) locations where the grommets were installed.
- Step 14: Reconnect the (3) wires to their respective locations on the metal bracket.
- Step 15: Install the new aFe air filter in the opening on the airbox. Verify that the small tabs click into the airbox by slightly pulling out on the air filter. Make sure the clamp is loosely installed over air filter.



Figure F

Refer to Figure F for Steps 16-18

Step 16: Install the intake tube into the vehicle by inserting the small end of the tube into the flexible coupler and then insert the other end of the tube into the air filter.

Step 17: Connect the MAF sensor harness to the sensor.

Step 18: Tighten both clamps to secure the intake tube.

**Figure G****Refer to Figure G for Steps 19-20**

Step 19: Make sure all connections are tight at this time, and all electrical connectors are securely fastened.

Step 20: If you would like to use the optional urethane plug to seal the airbox, then you may install it now. Your installation is now complete!

NOTE: Check all bolts, clamps, and connectors after 100-200 miles.



Pro DRY S Air Filter



P/N: 21-90089

Pro 5R Air Filter



P/N: 24-90089

Pro DRY S Restore Kit



P/N: 90-59999

Blue Squeeze Restore Kit



P/N: 90-50501

Throttle Body Spacer



P/N: 46-31007

Turbo Downpipe



P/N: 48-36302-HC (Street)
48-36302-HN (Race)

SCORCHER GT Module



P/N: 77-46314

Axle-Back Exhaust



P/N: 49-36327-P (Pol. Tips)
49-36327-B (Blk. Tips)

Cat-Back Exhaust



P/N: 49-36328-P (Pol. Tips)
49-36328-B (Blk. Tips)

Sprint Booster V3



P/N: 77-16302

Intercooler w/ Tubes



P/N: 46-20242-B

Dynamic Air Scoops



P/N: 54-11478 (Black)
54-11478-R (Red)