

GT
MOMENTUM™

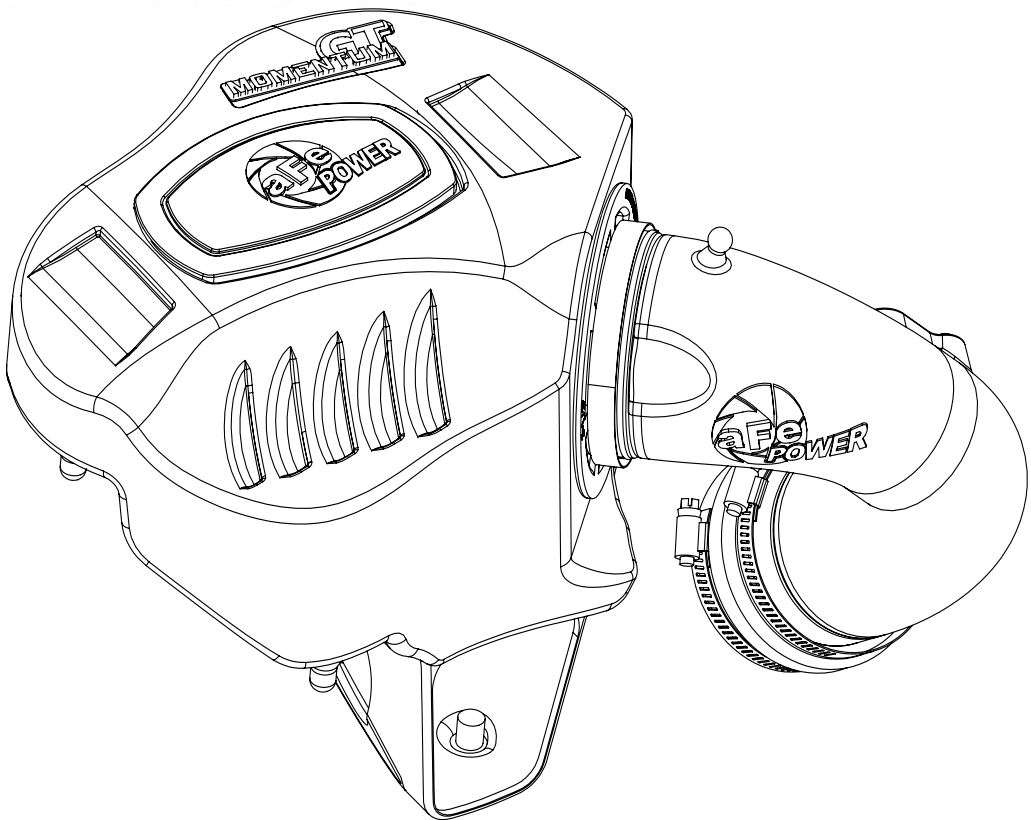

advanced FLOW engineering Momentum GT Cold Air Intake System

Instruction Manual P/N: 51-76312 / 54-76312

Make: **BMW** Model: **330i/ix/GT 430i/ix (F32/F33)** Year: **2016-2019** Engine: **L4-2.0L (t) B46/B48**
Make: **BMW** Model: **430i/ix Gran Coupe (F36)** Year: **2016-2019** Engine: **L4-2.0L (t) B46/B48**
Make: **BMW** Model: **230i/ix (F22/F23)** Year: **2017-2019** Engine: **L4-2.0L (t) B46/B48**



- Please read the entire instruction manual before proceeding.
- Ensure all components listed are present.
- Ensure you have all necessary tools before proceeding.
- Do not attempt to work on your vehicle when the engine is hot.
- Disconnect the negative battery terminal before proceeding.
- Retain factory parts for future use.

Label	Qty.	Description	Part Number
A1	1	Air Filter (Pro DRY S)	21-91103
A2	1	Air Filter (Pro 5R)	24-91103
B	1	Housing	05-76309B2
C	1	Tube	05-76312B1
D	1	Mount, Rubber	03-50534
E	2	Screw, Torx: M4	03-50490
F	1	Coupling, Silicone Dbl Hump	05-01416
G	2	Clamp #052	03-50008

Tools needed: 7mm, 8mm Nut driver, 10mm Nut Driver, 1/4" Ratchet, 10mm, 13mm Socket, Flathead Screw Driver, Pliers.

Note: Legal in California for use on race vehicles only. The use of this device on vehicles used on public streets or highways is strictly prohibited in California and others states that have adopted California emission regulations.

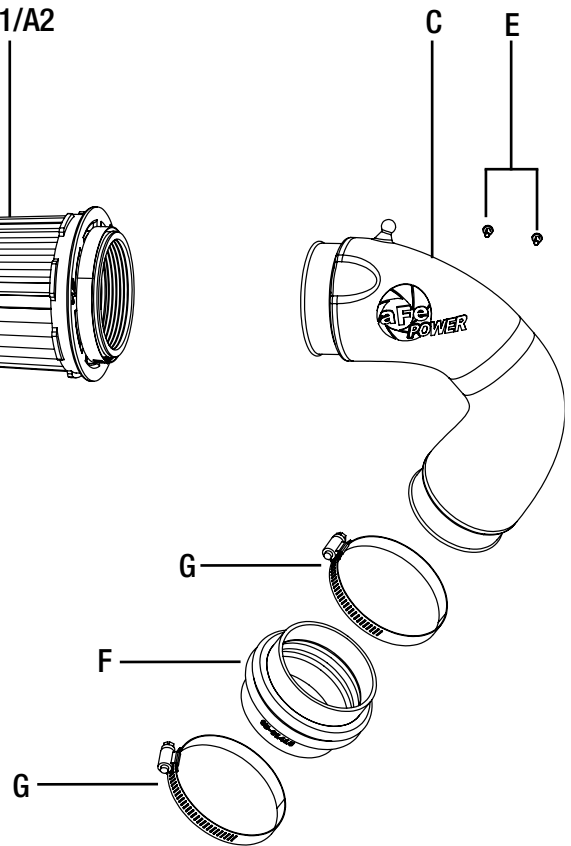
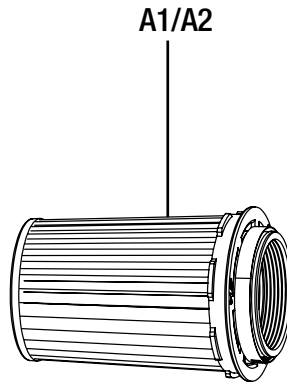
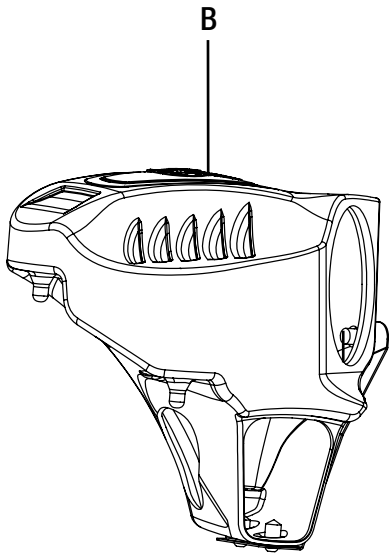



Figure A

Refer to Figure A for Steps 1-3

- Step 1: Remove the factory air intake cover by pulling on it then disconnect the Mass Air Flow (MAF) sensor.
- Step 2: Open the clamp securing the factory intake tube to the housing by prying it open then pull the factory air box out of the vehicle.
- Step 3: Loosen the clamp securing the intake tube to the turbo inlet tube, then take the intake tube out of the vehicle.

REMOVAL



Figure B

Refer to Figure B for Steps 4-5

- Step 4: Install the aFe filter into the aFe housing by firmly pushing it until it snap in. Install the clamp on the filter, but do not tighten as this time.
- Step 5: Install the provided grommet into the small hole at the bottom of the aFe housing.



Figure C

Refer to Figure C for Step 6

Step 6: Verify the two factory grommets stayed in their location when you removed the factory air box. If necessary, re-install them.

REMOVAL



Figure D

Refer to Figure D for Step 7

Step 7: Install the aFe housing assembly by firmly pushing it into the grommets.



Figure E

Refer to Figure E for Steps 8-9

- Step 8: Transfer the MAF sensor from the factory airbox to the aFe intake tube. Secure it using the provided screws.
- Step 9: Install the aFe coupling and clamps on to the tube. Do not tighten clamps at this time.



Figure F

Refer to Figure F for Steps 10-11

Step 10: Install the aFe tube into the vehicle by sliding on to the turbo inlet first, then into the filter.

Step 11: Align the tube, coupling and filter then tighten all clamps.



Figure G

Refer to Figure G for Steps 12-13

Step 12: Re-connect the MAF sensor harness.

Step 13: Re-install the factory intake cover if desired. Your installation is now complete.

NOTE: Check all clamps and connectors after 200 miles.

Check out the collection of performance air intake systems we offer.