

## advanced FLOW engineering

### Instruction Manual P/N: 52-76311 / 51-76311 / 54-76311

Make: **BMW** Model: **M2 (F87)**

Make: **BMW** Model: **335i/ix (F30/F34)**

Make: **BMW** Model: **435i/ix (F32/F33/F36)**

Make: **BMW** Model: **M135i/ix/M235i (F20/F21/F22)**

Year: **2016-2017** Engine: **L6-3.0L (t) N55**

Year: **2012-2015** Engine: **L6-3.0L (t) N55**

Year: **2014-2016** Engine: **L6-3.0L (t) N55**

Year: **2012-2016** Engine: **L6-3.0L (t) N55**



- Please read the entire instruction manual before proceeding.
- Ensure all components listed are present.
- Ensure you have all necessary tools before proceeding.
- Do not attempt to work on your vehicle when the engine is hot.
- Disconnect the negative battery terminal before proceeding.
- Retain factory parts for future use.

Label	Qty.	Description	Part Number
A1	1	Air Filter (Pro DRY S)	21-91108
A2	1	Air Filter (Pro 5R)	24-91108
B	1	Housing	05-76311B2
C	1	Tube	05-82202B1
D	1	Grommet, Air Temp Sensor	03-50033
E	1	Torx Bit: T20	03-50066
F	1	Cap: 1/2	03-50103
G	1	Fitting, Vacuum Line	05-01246
H	2	Screw, Torx: M4	03-50490

Tools needed: 7mm, 8mm Nut driver, 10mm Nut Driver, 1/4" Ratchet, 10mm, 13mm Socket, Flathead Screw Driver, Pliers.

Note: Legal in California for use on race vehicles only. The use of this device on vehicles used on public streets or highways is strictly prohibited in California and others states that have adopted California emission regulations.

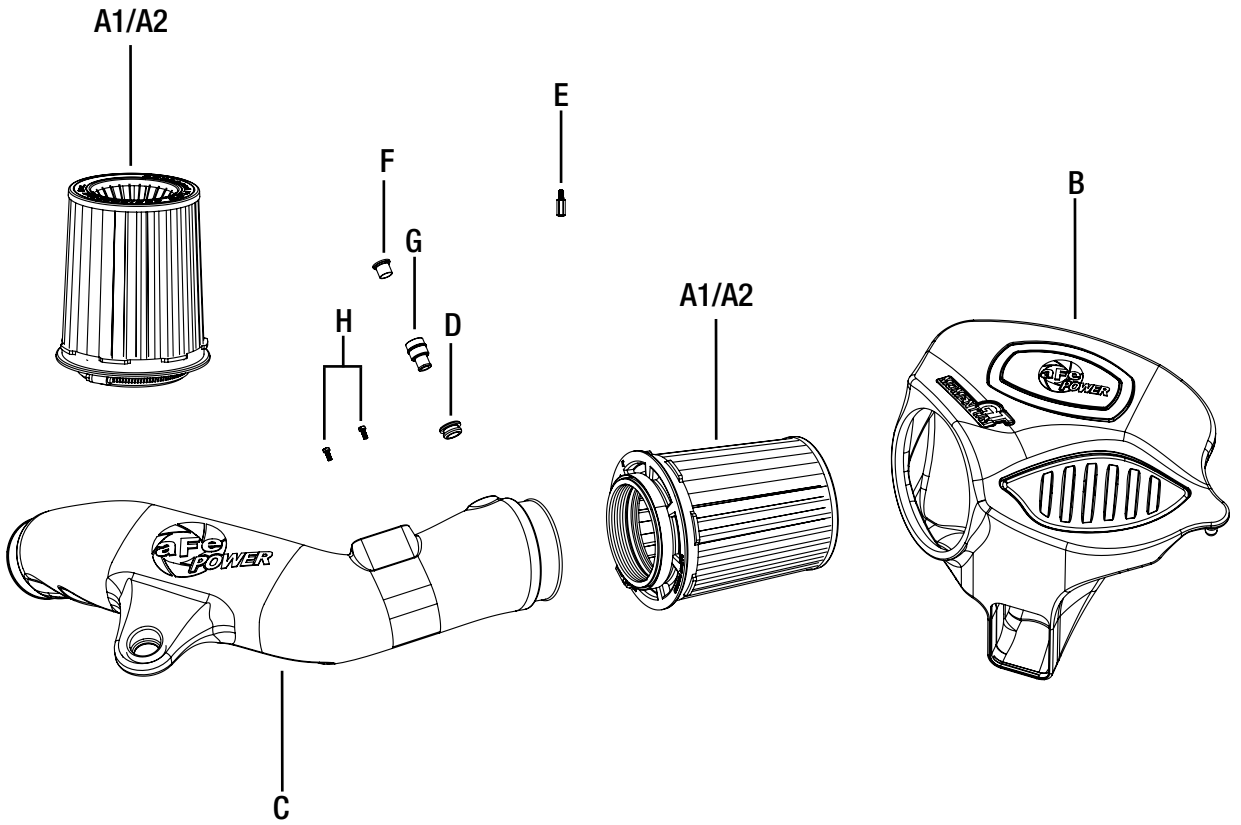



**Refer to Figure A for Step 1**

Step 1: If your vehicle is equipped with a brace, take it off by removing the four 13mm bolts.



Figure B

**Refer to Figure B for Steps 2-5**

Step 2: Disconnect the MAF sensor.

Step 3: Unplug the vacuum line (if your vehicle is equipped with one)

Step 4: Loosen the clamp on factory intake tube.

Step 5: Remove the factory intake system out of the vehicle by pulling it off the mounting grommets.

**Figure C****Refer to Figure C for Steps 6-8**

Step 6: Remove the MAF sensor off the factory intake tube using the furnished T20 torx and install onto aFe intake tube with the furnished screws.

Step 7: Remove OE grommet off intake tube and install on aFe intake tube.

Step 8: If your vehicle had a vacuum line connected to the factory intake tube, install the provided grommet and aluminum fitting into the hole of aFe intake tube. For vehicle not equipped with vacuum line, simply cap off the hole with grommet and plug provided.





Figure D

**Refer to Figure D for Step 9**

Step 9: Pick the dry or oiled filter and push it into the housing until it snaps into place.

**Figure E****Refer to Figure E for Steps 10-11**

Step 10: Install the aFe housing in the vehicle by pushing it into the factory grommets. Make sure housing line up to the factory air inlet duct.

Step 11: Slide the aFe intake tube into factory inlet tube and into aFe filter. Then push the grommet in the mounting location. Tighten all clamps.



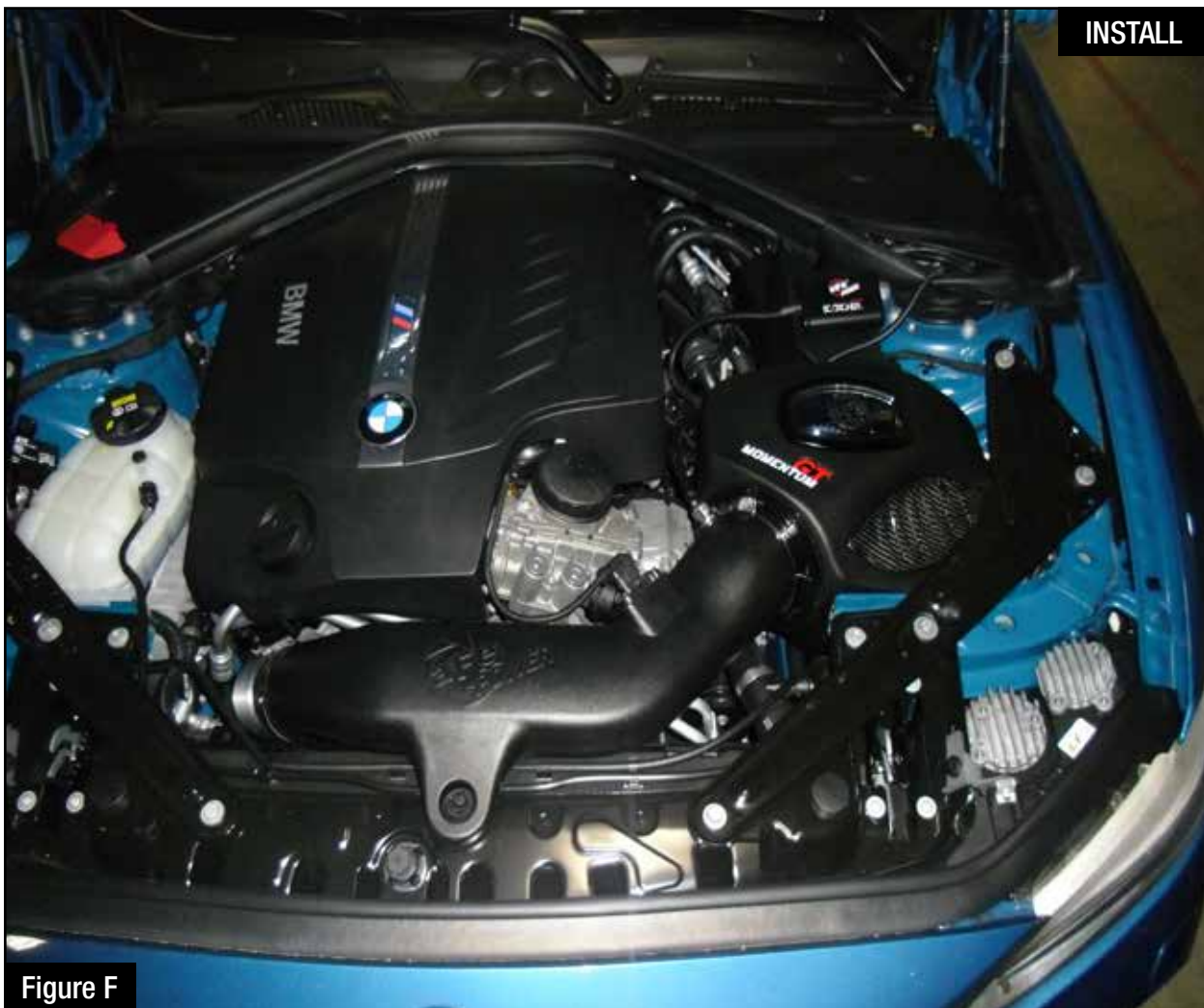

### **Refer to Figure F for Steps 12-15**

Step 12: Lift up the engine cover and re-route the MAF harness around the oil filter housing. Then re-connect it to the MAF sensor.

Step 13: Re-connect the vacuum line to aluminum fitting (automatic vehicle only)

Step 14: Re-install the factory brace with the four 13mm bolts.

Step 15: Verify all clamps are secure and re-check periodically. Your Installation is now complete.



Pro DRY S Air Filter



P/N: 21-91108

Pro 5R Air Filter



P/N: 24-91108

Pro DRY S Restore Kit



P/N: 90-59999

Blue Squeeze Restore Kit



P/N: 90-50501

Blue Aerosol Restore Kit



P/N: 90-50001

Twisted Steel Down-Pipe



P/N: 48-36316-HC (Street)  
48-36316-HN (Race)

Exhaust System



P/N: 49-36330-C (C/F Tips)  
49-36330-B (Blk Tips)  
49-36330-P (Pol Tips)

Axle-Back Exhaust System



P/N: 49-36333-C (C/F Tips)  
49-36333-B (Blk Tips)  
49-36333-P (Pol Tips)

Dynamic Air Scoop



P/N: 54-12208 (Black)  
54-12208-C (C/F)

Sprint Booster



P/N: 77-16301 (M/T)

Intercooler w/ Tube



P/N: 46-20272-B

Coilovers



P/N: 430-503001-N