

advanced FLOW engineering

Instruction Manual P/N: 51-76303 & 54-76303

Make: **BMW** Model: **528i/ix (F10)** Year: **2012-2016** Engine: **L4-2.0L (t) N20**



- Please read the entire instruction manual before proceeding.
- Ensure all components listed are present.
- If you are missing any of the components, call customer support.
- Ensure you have all necessary tools before proceeding.
- Do not attempt to work on your vehicle when the engine is hot.
- Disconnect the negative battery terminal before proceeding.
- Retain factory parts for future use.

Label	Qty.	Description	Part Number
A1	1	Pro DRY S Air Filter	21-91088 (Gray Media)
A2	1	Pro 5R Air Filter	24-91088 (Blue Media)
B	1	Clamp, 096 4-1/2"-6-1/2"	03-50003
C	1	Torx Bit: T20	03-50066
D	2	Screw, M4	03-50221
E	1	Plug, Urethane	05-01225
F	1	Tube, Rotomold	05-76303B1
G	1	Housing, Rotomold	05-76303B2

Installation will require the following tools:

6mm and 8mm nut driver, flat screwdriver, T30 Torx, 16mm socket, ratchet and extension.

Note: Legal in California for use on race vehicles only. The use of this device on vehicles used on public streets or highways is strictly prohibited in California and others states that have adopted California emission regulations.

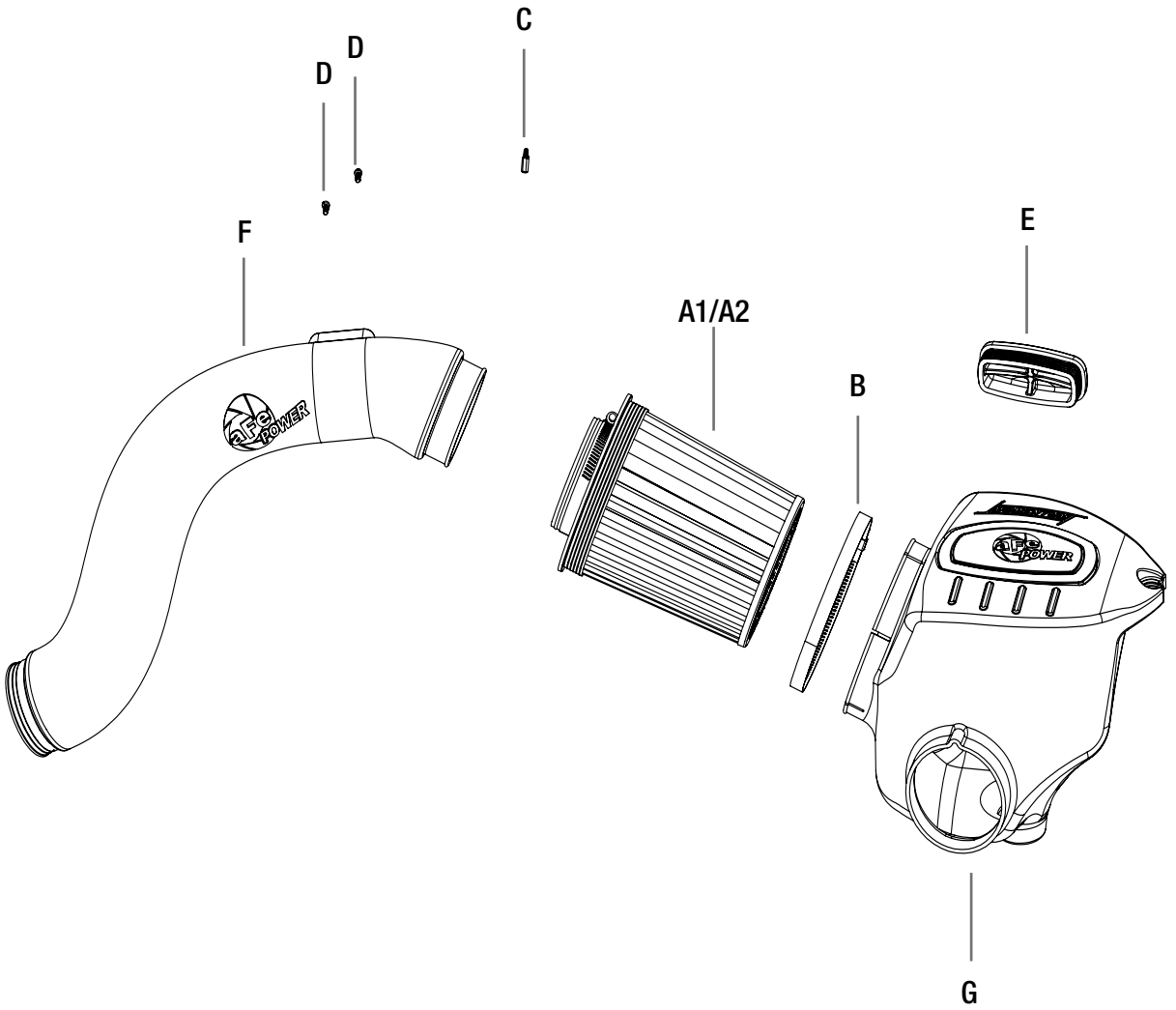

**Figure A****Refer to Figure A for steps 1-4**

Step 1: Disconnect the Mass Air Flow (MAF) sensor harness ①.

Step 2: Using the 16mm socket, remove the two bolts ② securing the re-enforcement bar. Then remove the bar out of the vehicle. It will be re-installed later.

Step 3: Remove the bolt ③ securing the air box using a T30 torx.

Step 4: Loosen the clamp ④ at the turbo inlet tube then pull the complete air box and tube out of the vehicle.

**Figure B****Refer to Figure B for steps 5-7**

Step 5: Transfer the grommet (5) from the factory air box to the aFe housing.

Step 6: Slide the aFe filter into the housing. Secure it using the furnished big clamp.

Step 7: If desired, install the furnished plug (6) onto the extra air inlet opening to close it off. This will protect the filter from the engine compartment air and will also make the intake quieter.



Figure C

Refer to Figure C for step 8

Step 8: Install the housing assembly into the vehicle. The housing will sit on the factory dome grommet and the air inlet duct will connect to the housing.

INSTALL



Figure D

Refer to Figure D for steps 9-10

Step 9: Remove the MAF sensor from the factory air box using the furnished T20 torx bit.

Step 10: Transfer it to the aFe tube and secure it using the furnished M4 Screws.



Figure E

Refer to Figure E for steps 11-12

Step 11: Install the tube into the vehicle by first sliding the tube into the turbo inlet pipe then the other end into the filter.

Step 12: Align the tube and tighten all clamps. Use the factory clamp at the turbo inlet and the furnished clamp at the filter.

**Figure F****Refer to Figure F for steps 13-16**

Step 13: Secure the aFe housing using the factory T30 torx bolt ⑦.

Step 14: Re-install the re-enforcement bar and tighten the bolts to factory specs

Step 15: Re-connect the MAF sensor harness.

Step 16: Verify all clamps are secure and re-check periodically.

Your installation is now complete.



Pro DRY S Air Filter



P/N: 21-91088

Pro 5R Air Filter



P/N: 24-91088

Pro DRY S Restore Kit



P/N: 90-59999

Sprint Booster



P/N: 77-16304

aFe Euro Plate



P/N: 40-10135

Module



P/N: 77-46303

Air Filter



P/N: 30-10227

aFe Power Hat



P/N: 40-10083

Warranty

General Terms:

- aFe warrants their products to be free from manufacturer's defects due to workmanship and material.
- This warranty applies only to the original purchaser of the product and is non-transferrable.
- Proof of purchase of the aFe product is required for all warranty claims.
- Warranty is valid provided aFe instructions for installation and/or cleaning were properly followed.
- Proper maintenance with regular inspections of product is required to insure warranty coverage.
- Damage due to improper installation, abuse, unauthorized repair or alteration is not warranted.
- Incidental or consequential damages or cost, including installation and removal of part, incurred due to failure of aFe product is not covered under this warranty.
- All warranty is limited to the repair and/or replacement of the aFe part. To request Return Goods Authorization ("RGA"). Upon receipt of the RGA, you must return the product to the address provided in the RGA, freight prepaid and accompanied with a dated proof of purchase and the RGA. Upon receipt of the defective product and upon verification of proof of purchase, aFe will either repair or replace the defective product within a reasonable time, not to exceed thirty days.

Product Category	P/N Prefix	Warranty duration
Direct OE Replacement Filters	10, 11, 30, 31, 71, 73	Life of the vehicle
Racing Filters	18	1 year
Universal	21, 24, 72	2 years
Air Intake Systems	50, 51, 54, 55, 75	2 years
Exhaust Systems	49	2 years
Intercoolers & Intercooler Tubes	46-2	2 years
Intake Manifolds	46-1	2 years
Differential Cover	46-7	Life of the vehicle
Exhaust Manifolds	46	2 years
Throttle Body Spacers	46-3	2 years
Fluid Filters	44	90 days
Pre-Filters	28	2 years
Heavy Duty OE Replacement	70	2 years
PowerSports OE Replacement	81, 87	2 years
PowerSports Intake Systems	85	2 years

No other warranty expressed or implied applies nor is any person or advanced FLOW engineering authorized to assume any other warranty. Some States do not allow the exclusion or limitation of incidental or consequential damages or do not allow limitations on how long an implied warranty lasts, so the above limitations or exclusions may not apply to you. This warranty gives you specific legal rights, and you may also have other rights which vary from State to State.

Buy quality performance air intake systems in our online store.