

advanced FLOW engineering

Instruction Manual P/N: 51-76108 / 54-76108

Make: **Nissan** Model: **Titan** Year: **2017-2019** Engine: **V8-5.6L**



- Please read the entire instruction manual before proceeding.
- Ensure all components listed are present.
- If you are missing any of the components, call customer support.
- Ensure you have all necessary tools before proceeding.
- Do not attempt to work on your vehicle when the engine is hot.
- Disconnect the negative battery terminal before proceeding.
- Retain factory parts for future use.

Label	Qty.	Description	Part Number
A1	1	Air Filter (Pro DRY S)	21-91124
A2	1	Air Filter (Pro 5R)	24-91124
B	1	Tube	05-76103B1
C	1	Housing	05-76108B2
D	2	Clamp, #064	03-50006
E	1	Coupling, Silicone Double Hump	05-01389
F	1	Hose, Adaptor CCV (Silicone)	05-01346
G	1	Plug, Urethane	05-01202

Tools needed: 8mm Nut driver, 10mm/12mm Nut Driver, 11mm Deep Socket, 1/4" Ratchet, Flathead Screw Driver, Phillips Screw Driver, Pliers.

Note: Legal in California for use on race vehicles only. The use of this device on vehicles used on public streets or highways is strictly prohibited in California and others states that have adopted California emission regulations.

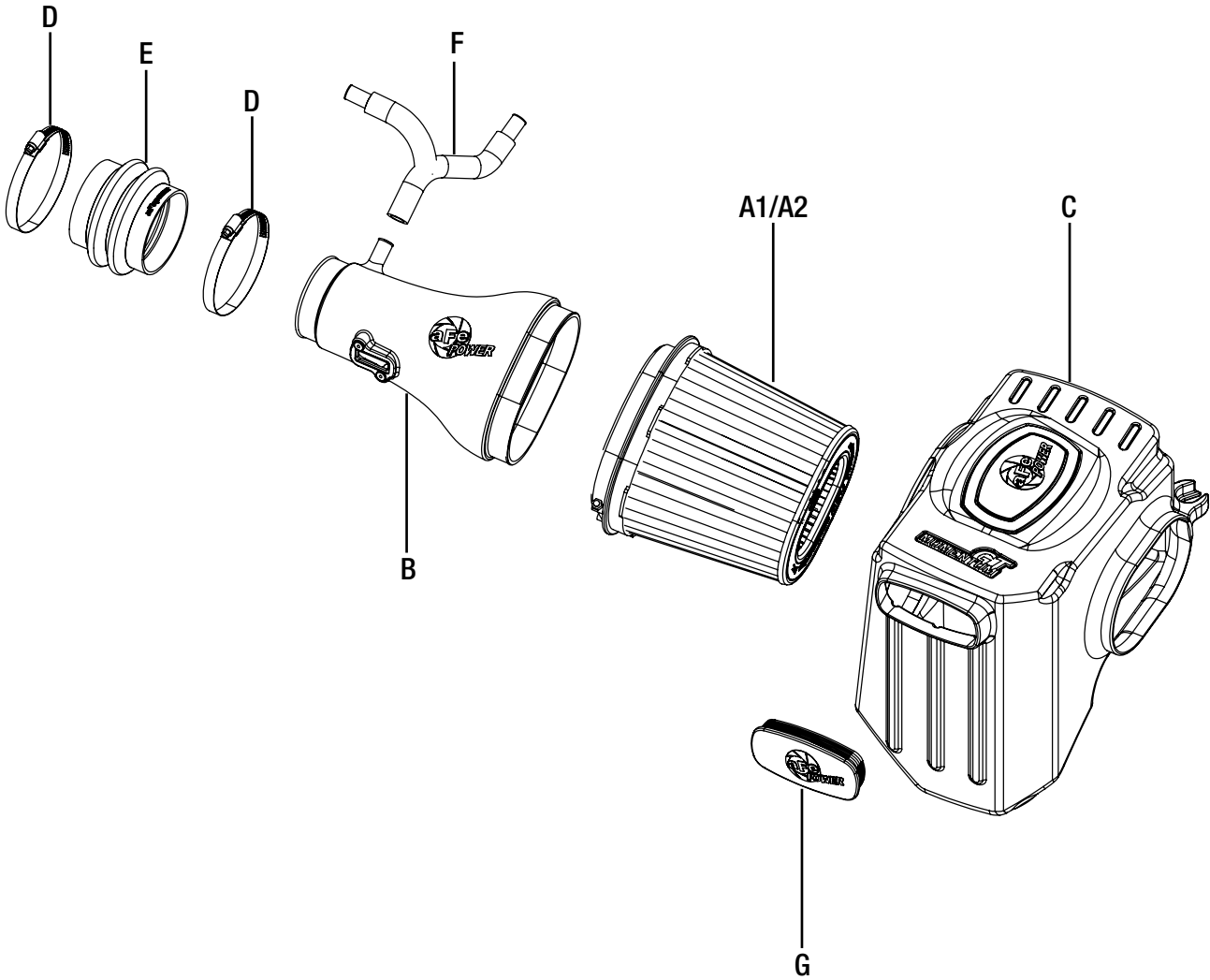



Figure A

Refer to Figure A for Step 1

Step 1: Remove the engine cover by lifting and pulling up and towards you.



Figure B

Refer to Figure B for Steps 2-6

Step 2: Using a 8mm nut driver, loosen the hose clamp ① at the throttle body.

Step 3: Using a 10mm nut driver, remove the OE bolt ② securing the OE housing in place.

Step 4: Unclip the Mass Air Flow (MAF) sensor ③ from the tube.

Step 5: Carefully detach all clips ④ securing the MAF sensor wiring harness to the OE housing.

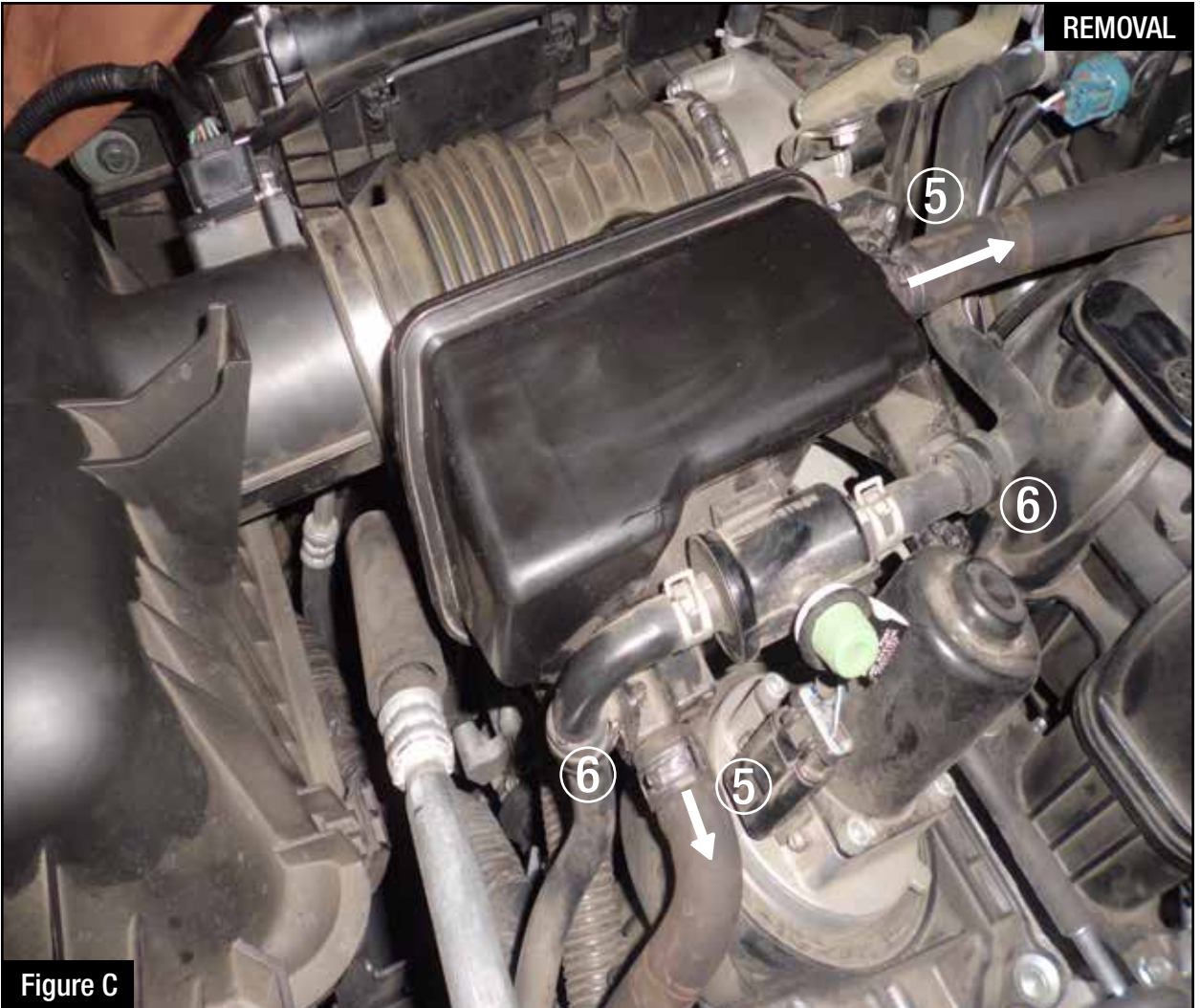
**Figure C****Refer to Figure C for Steps 6-9**

Step 6: Compress the metal spring clamps (5) on both crank case vent (CCV) hoses and slide down the hose.

Step 7: Disconnect both CCV hoses from the resonance chamber and position out of the way.

Step 8: Unclip and remove both plastic clips (6) connecting the rubber evap hose to the resonance chamber.

Step 9: Remove the entire OE intake assembly at this time.

**Figure D****Refer to Figure D for Steps 10-12**

Step 10: Remove the steel sleeves and rubber grommets (7) from the OE housing and transfer on the aFe housing as shown.

Step 11: Install the air filter into the housing (8).

Step 12: Install the aFe housing and air filter into the vehicle. Tighten the housing down with the OE screw removed in Step 3. (9)

Note: If you prefer to completely seal the airbox, use the provided plug to close the auxiliary air inlet.



Figure E

Refer to Figure E for Steps 13-14

Step 13: Using a phillips head screwdriver, remove both screws and MAF sensor. You will reuse both screws.

Step 14: Transfer the MAF sensor to the aFe tube ⑩ and secure using the two OE screws.



Figure F

Refer to Figure F for Steps 15-17

Step 15: Install the aFe tube into the vehicle. Insert into the air filter. Do not tighten clamp.

Step 16: Slip the supplied coupling and clamps onto the aFe tube and throttle body. ⑪

Step 17: Adjust the tube to fit comfortably and tighten all clamps.

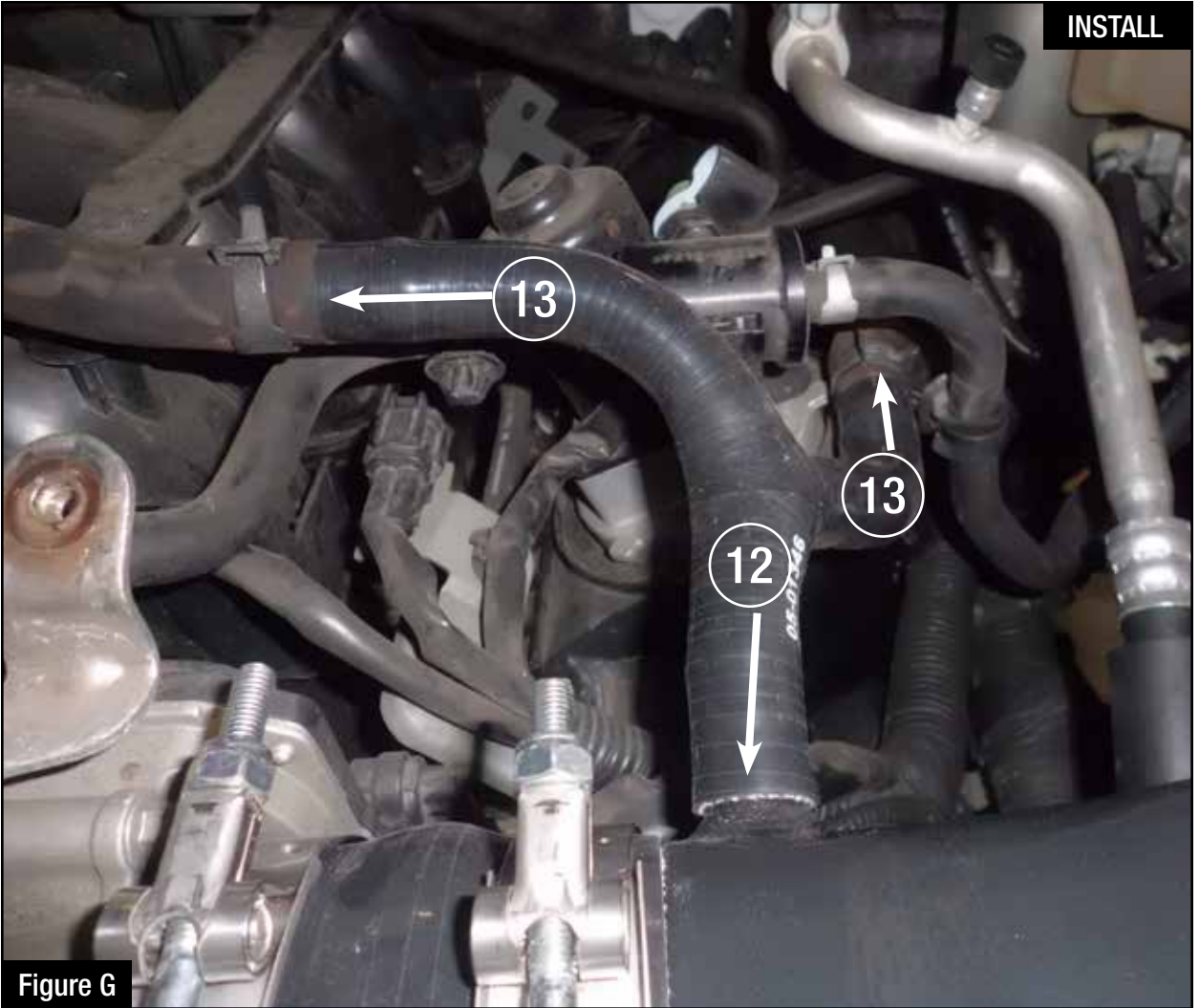
**Figure G****Refer to Figure G for Steps 18-19**

Step 18: Install the provided silicone hose: place the end with no metal fitting (12) over the nipple on the aFe tube.

Step 19: Install the remaining two ends of the adaptor with the stainless fittings into the OE CCV hoses (13) and reposition the spring clamps.



Figure H

Refer to Figure H for Steps 20-22

Step 20: Connect the MAF sensor (14).

Step 21: Make sure all clamps and connections are secured.

Step 22: Reinstall the engine cover at this time. Your installation is now complete. Thank you for choosing aFe POWER!

NOTE: Check all bolts, clamps and connectors after 200 miles.



Pro DRY S Air Filter



P/N: 21-91124

Pro 5R Air Filter



P/N: 24-91124

Pre-Filter



P/N: 28-10283

Dynamic Air Scoop



P/N: 54-76108-S

Pro DRY S Restore Kit



P/N: 90-59999

Blue Squeeze Restore Kit



P/N: 90-50501

Cat-Back Exhaust System



P/N: 49-46125-B (Blk. Tips)
49-46125-P (Pol. Tips)

Side-Exit Exhaust System



P/N: 49-46126-B (Blk. Tips)
49-46126-P (Pol. Tips)

Rear Differential Cover



P/N: 46-70362-WL (w/ Oil)

Oil Filter



P/N: 44-LF016