

MOMENTUM **HD**

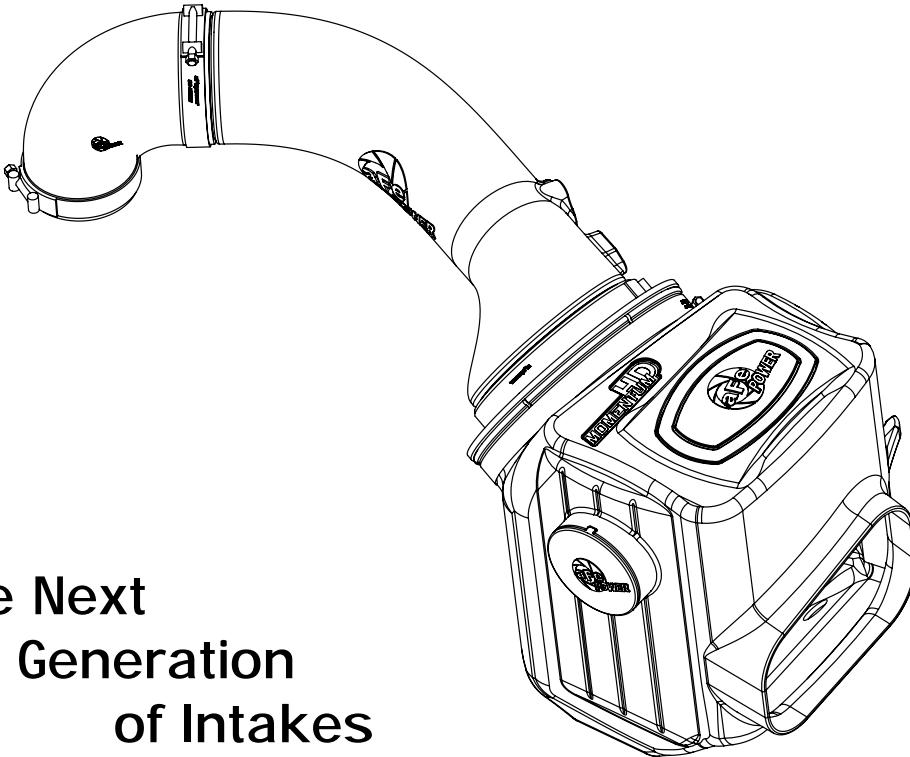

The Next
Generation
of Intakes

advanced FLOW engineering

Instruction Manual P/N: 50-76105 / 51-76105 Momentum Air Intake

Make: **Nissan**

Model: **Titan XD**

Year: **2016-2019**

Engine: **V8-5.0L (td) Cummins**



- Please read the entire instruction manual before proceeding.
- Ensure all components listed are present.
- If you are missing any of the components, call technical support.
- Ensure you have all necessary tools before proceeding.
- Do not attempt to work on your vehicle when the engine is hot.
- Disconnect both the negative battery terminal before proceeding.

Retain factory parts for future use.

Label	Qty.	Description	Part Number
A1	1	Pro 10R (Blue Media)	20-91059
A2	1	Pro DRY S (Gray Media)	21-91059
B	1	Tube	05-76105B1
C	1	Housing	05-76105B2
D	1	Plug, Urethane	05-01361
E	1	Coupling, Silicone Elbow	05-01402
F	1	Clamp, T-bolt (8-5/16"-8-5/8")	03-50267
G	1	Clamp, T-bolt (3-9/16"-3-7/8")	03-50498
H	1	Clamp, T-bolt (4-1/16"-4-3/8")	03-50262
I	3	Screw, Torx: M4 x .7 x 8mm	03-50490

Installation will require the following tools:

10mm, 7/16" nut driver or socket, T15 driver, pliers and wrench.

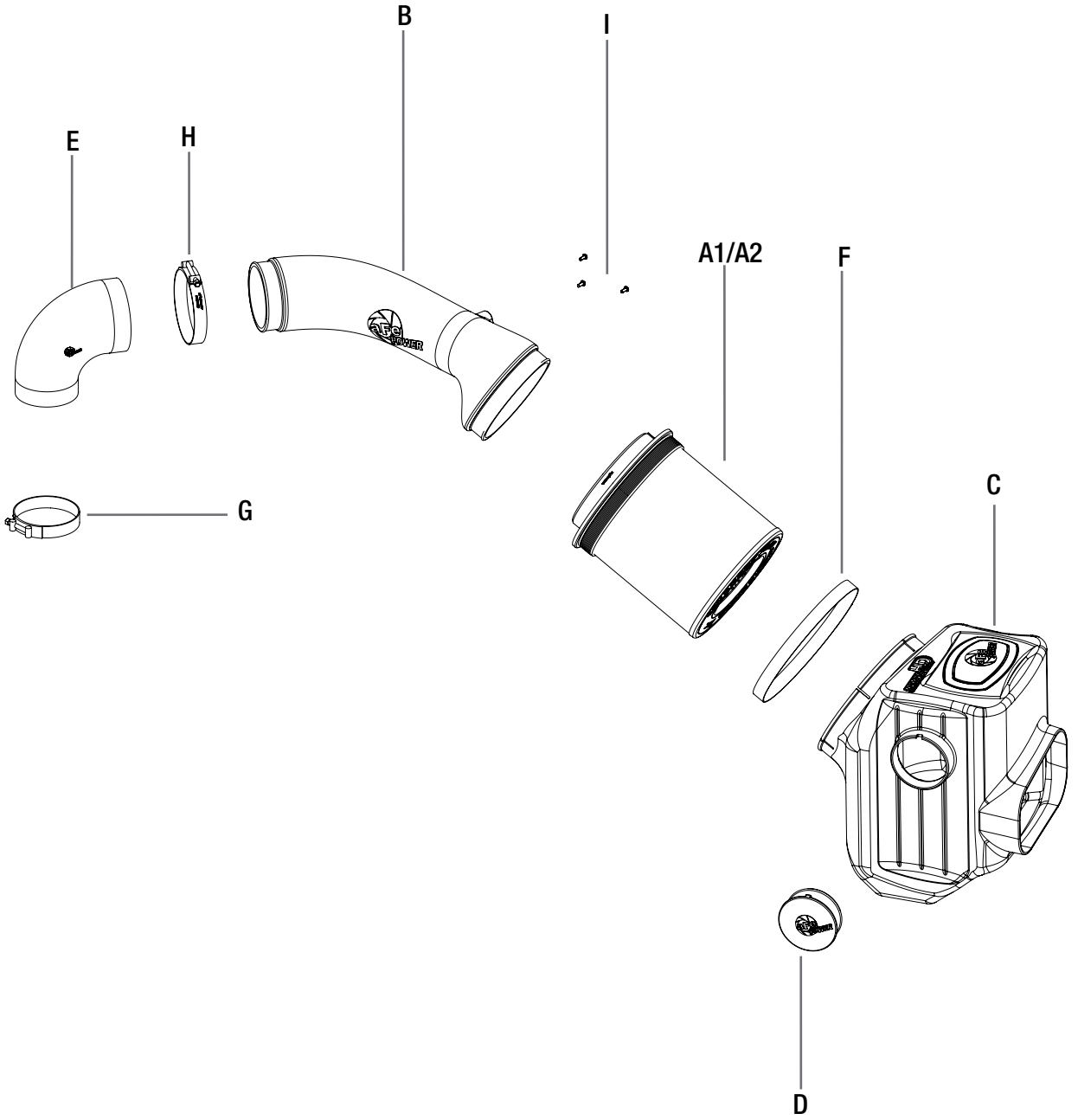

**Figure A****Refer to Figure A for Steps 1-4**

Step 1: Disconnect the Mass Air Flow (MAF) sensor and the temperature sensor harnesses.

Step 2: Loosen the clamp on the factory intake tube to the turbo inlet.

Step 3: Remove the two spring clip connecting the top to the bottom of the factory housing. Then pull the tube and top of the housing outside of the vehicle.

Step 4: Remove the flat panel air filter.



Figure B

Refer to Figure B for Steps 5-6

Step 5: Remove the 10mm bolt securing the bottom of the housing to the truck. The bolt is located on the firewall side. This bolt will be re-used.

Step 6: Pull the bottom of the factory housing out of the vehicle. Also remove the factory intake duct going into the side fender.



Refer to Figure C for Steps 7-8

Step 7: Transfer the 3 rubber isolation mounts from the bottom of the factory housing to the aFe housing.

Step 8: Install the big clamp on the aFe housing. Do not tighten yet.



Figure D

Refer to Figure D for Steps 9-10

Step 9: Install the aFe housing inside the vehicle. Firmly push the housing into the two bottom studs.

Note: It may help to use a small amount of lubricant in the inside of the rubber grommet.

Step 10: Secure the housing using the factory bolt removed at Step 5.



Figure E

Refer to Figure E for Step 11

Step 11: Insert the filter in the housing with the clamps installed. Do not tighten yet.

**Figure F****Refer to Figure F for Step 12**

Step 12: Transfer the MAF sensor and the temperature sensor from the factory housing to the aFe tube. Secure them using the furnished M4 screws.

**Figure G****Refer to Figure G for Steps 13-15**

- Step 13: Install the 90 degrees coupling onto the turbo inlet of the truck. Install the clamps but do not tighten yet.
- Step 14: Slide the aFe tube into the coupling then into the filter. Align the tube, coupling and filter then tighten all clamps.
- Step 15: Re-connect the MAF sensor and temperature harnesses.



Figure H

Refer to Figure H for Steps 16-18

Step 16: If you have purchased the aFe air scoop (P/N: 54-76105-S), install it referring to its install instruction sheet.

Step 17: If you don't have the air scoop, you have the option to close off the extra air inlet with the furnished plug or to keep it open.

- Without the plug installed, the aFe Power intake will capture the maximum air available. More airflow offers more power. Yet some of this air is picked up from inside the engine compartment and could be warmer air. Warmer air will affect the performance of the vehicle.
- The plug installed on the housing will block off any hot engine air entering the housing and make sure the coolest air available is directed into the engine. It will also reduce the noise of the intake.

Step 18: Verify all connection are secured. The installation is now completed.

NOTE: Place enclosed CARB EO sticker on or near the intake system on a smooth/clean surface.

EO identification label is required to pass the smog test inspection.



Pro DRY S Air Filter



P/N: 21-91059

Pro 10R Air Filter



P/N: 20-91059

Pro-GUARD 7 Air Filter



P/N: 72-91059

Pro DRY S Restore Kit



P/N: 90-59999

Blue Squeeze Restore Kit



P/N: 90-50501

Gold Squeeze Restore Kit



P/N: 90-50500

Pre-Filter



P/N: 28-10273

Dynamic Air Scoop



P/N: 54-76105-S

SCORCHER HD Module



P/N: 77-46101

DPF-Back Exhaust System



P/N: 49-46113-B (Blk Tip)
49-46113-P (Pol Tip)

Intercooler w/ Tubes



P/N: 46-20282-B

Rear Differential Cover



P/N: 46-70362-WL (w/ Oil)
46-70360 (RAW)

Check out the collection of performance air intake systems we offer.