

advanced FLOW engineering

Instruction Manual P/N: 51-76007 / 54-76007 / 75-76007

Make: **Toyota** Model: **Land Cruiser (LC200/J200)** Year: **2008-2011** Engine: **V6-4.0L**



- Please read the entire instruction manual before proceeding.
- Ensure all components listed are present.
- If you are missing any of the components, call technical support.
- Ensure you have all necessary tools before proceeding.
- Do not attempt to work on your vehicle when the engine is hot.
- Disconnect both the negative battery terminal before proceeding.

Retain factory parts for future use.

Label	Qty.	Description	Part Number
A1	1	Pro DRY S (Gray Media)	21-91092
A2	1	Pro 5R (Blue Media)	24-91092
A3	1	Pro-GUARD 7 (Gold Media)	72-91092
B	1	Tube	05-76007B1
C	1	Housing	05-76006B2
D	1	Plug, Urethane	05-01202
E	1	Coupling, Silicone Reducer	05-01400
F	1	Clamp, T-bolt (3-1/4" - 3-9/16")	03-50292
G	1	Seal Trim (26" inches)	05-00007
H	1	Clamp, T-bolt (3-1/16" - 3-3/8")	03-50320
I	2	Screw, Torx: M4	03-50491
J	1	Fitting, Nipple, Brs Hose	03-50191
K	1	Hose, Vacuum (20" inches)	05-00122

Installation will require the following tools:

10mm & 8mm nut drivers, pliers, T20 & T30 drivers, 10mm & 11mm deep socket & driver, flathead screwdriver, phillips screwdriver and 7/16" wrench.

Note: Not legal for use in California. The use of this device in any on-road or off-road vehicles registered with the California Dept of Motor Vehicles (DMV) is strictly prohibited.

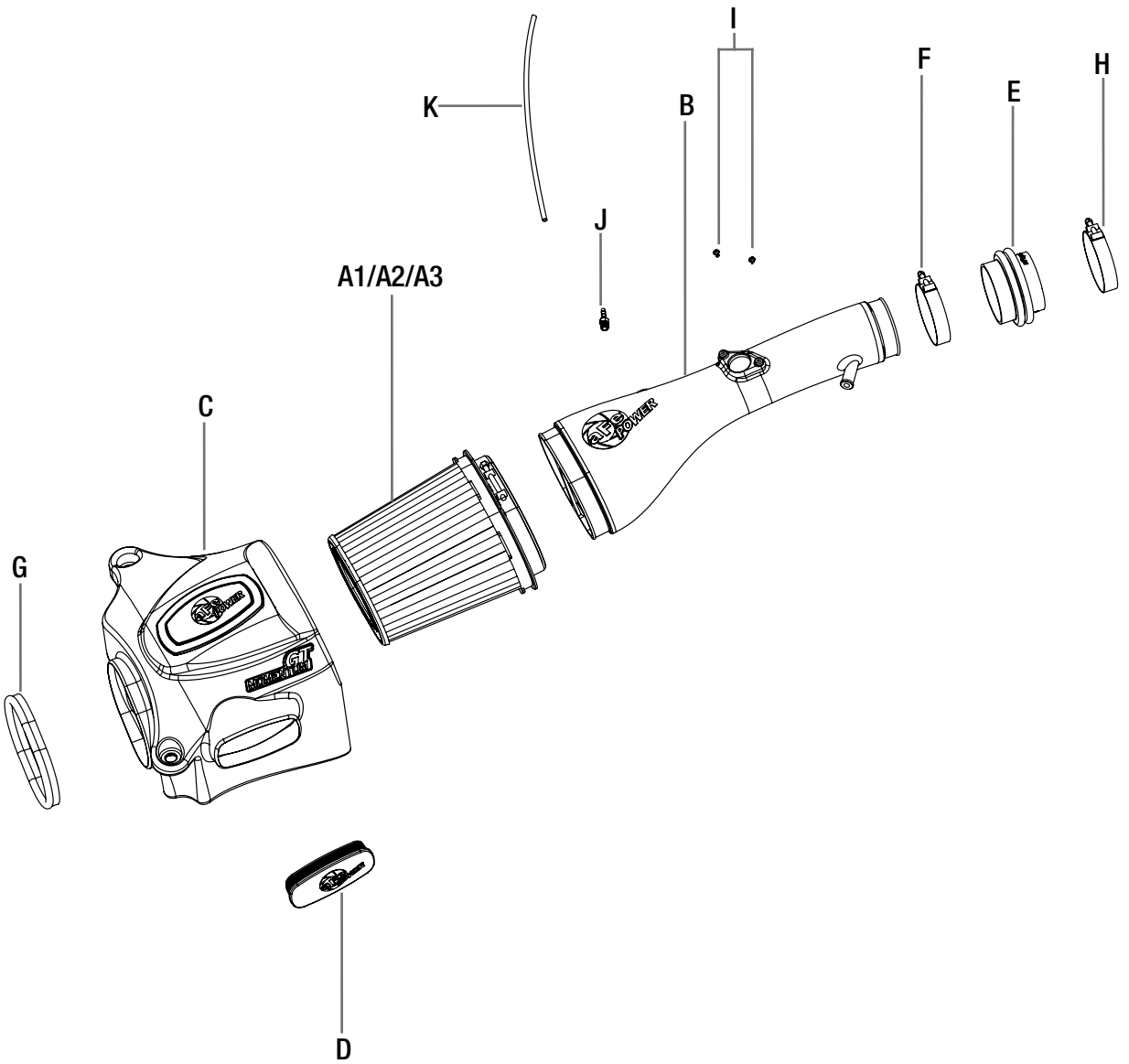

**Figure A****Refer to Figure A for Step 1**

Step 1: Remove the 2 nuts securing the engine cover. Then remove the engine cover. It won't be re-install with the aFe Power intake.



Refer to Figure B for Steps 2-3

Step 2: Remove the factory inlet tube, by untightening the clamps securing the tube.

Step 3: Remove the 3 screws securing the bracket holding the tube to the side fender, then remove the tube and bracket. Those screws and grommet will be re-used to install the aFe Power Housing.



Figure C

Refer to Figure C for Step 4

Step 4: Remove the screw holding the black sheet metal blocking the opening in the fender, then remove the duct to allow more air coming in.



Figure D

Refer to Figure D for Steps 5-8

Step 5: Disconnect the Mass Air Flow (MAF) Sensor harness and unclip it from the factory airbox.

Step 6: Disconnect the vacuum hose next to the throttle body on the factory airbox. The hose will be re-used with the factory intake.

Step 7: Disconnect the small hose connecting to the back for the factory airbox (by the firewall). This hose will be replaced by a longer hose furnished.

Step 8: Remove the two screws securing the factory airbox, untighten the clamp at the throttle body then pull the airbox assembly out of the vehicle.



Figure E

Refer to Figure E for Step 9

Step 9: Transfer the three grommet and screws from the factory air inlet duct bracket to the aFe Power housing. One goes on the inside of the housing.

INSTALL



Figure F

Refer to Figure F for Step 10

Step 10: Install the provided trim seal on the inlet of the aFe Power housing.



Figure G

Refer to Figure G for Step 11

Step 11: Install the aFePower housing in the vehicle. Secure it by tightening the three factory screws.



Figure H

Refer to Figure H for Step 12

Step 12: Slide the aFePower filter and clamp into the aFe housing and push it in until it locks into place. Do not tighten clamp at this time.

**Figure 1****Refer to Figure 1 for Steps 13-15**

Step 13: Transfer the MAF sensor from the factory airbox to the aFePower intake tube. Secure it using the provided small screws.

Step 14: Install the provided brass nipple fitting onto the NPT fitting on the tube. Firmly tighten it.

Step 15: Install the bigger round clamp on the small end of the tube. Do not tighten yet.



Figure J

Refer to Figure J for Step 16

Step 16: Install the coupling with clamp on the throttle body. This is a reducer coupling; the throttle body side is the smaller side. The clamps are also different size and the smaller one goes on the throttle body side. Do not tighten yet.

**Figure K****Refer to Figure K for Steps 17-21**

Step 16: Slide the aFePower intake tube into the filter then the other side into the coupling on the throttle body.

Step 17: Align the tube correctly and tighten all clamps.

Step 18: Reconnect the MAF sensor harness.

Step 19: Reconnect the big vacuum hoses to the aFe Power tube. Secure it using the factory clamp.

Step 20: Replace the small vacuum hose by the longer hose provided. Connect the brass fitting on the tube to the factory location on the engine.

**Figure L****Refer to Figure L for Step 22**

Step 22: The kit includes an optional plug to close off the front auxiliary air inlet. Install the plug if you wish to close off the front auxiliary air inlet and only capture cold air from the side fender.

- Without the plug installed, the aFe Power intake will capture the maximum air available. More airflow offers more power. Yet some of this air is picked up from inside the engine compartment and could be warmer air. Warmer air will affect the performance of the vehicle.
- The plug installed on the housing will block off any hot engine air entering the housing and make sure the coolest air available is directed into the engine. It will also reduce the noise of the intake.

**Figure M****Refer to Figure M for Steps 23-24**

- Step 23: If you purchased the optional aFe Power air scoop, install it following the install instruction.
- Step 24: Verify all connections are secured. The installation is now completed, enjoy your aFe Power air intake system.

NOTE: Check all bolts, clamps and connectors after 100-200 miles.



Pro DRY S Air Filter



P/N: 21-91092

Pro 10R Air Filter



P/N: 20-91092

Pro-GUARD 7 Air Filter



P/N: 72-91092

Pre-Filter



P/N: 28-10283

Pro DRY S Restore Kit



P/N: 90-59999

Blue Squeeze Restore Kit



P/N: 90-50501

Gold Squeeze Restore Kit



P/N: 90-50500

Dynamic Air Scoop



P/N: 54-76006-S