

advanced FLOW engineering

Instruction Manual P/N: 51-76003 and 54-76003

Make: **Toyota** Model: **Tundra** Year: **2007-2015** Engine: **V8-5.7L**



- Please read the entire instruction manual before proceeding.
- Ensure all components listed are present.
- If you are missing any of the components, call customer support.
- Ensure you have all necessary tools before proceeding.
- Do not attempt to work on your vehicle when the engine is hot.
- Disconnect the negative battery terminal before proceeding.

Retain factory parts for future use.

Label	Qty.	Description	Part Number
A1	1	Air Filter (Pro DRY S)	21-91072 (51-76003)
A2	1	Air Filter (Pro-5R)	24-91072 (54-76003)
B	1	Tube	05-76003B1
C	1	Housing	05-76003B2
D	2	Clamp, 56 (3-1/16"-4")	03-50009
E	1	Clamp, T-Bolt (8-5/16"-8-5/8") SS	03-50267
F	1	Coupling, Straight 3-1/2" ID x 2"L (BLK)	05-00307
G	2	Screw, Chs Hd M4 x .7x8	05-50034
H	1	Fitting, Hose 3/16" ID x 1/8 npt	03-50191
I	1	Hose, Fuel 1/2 ID Black @ 18"L	05-00027
J	1	Plug	05-01202

Tools needed: 8mm Nut driver, 10 mm Nut driver, Standard pliers or channel locks, Phillips head screwdriver, Flat head screw driver, 1/4" ratchet, 10mm socket.

Note: Legal in California for use on race vehicles only. The use of this device on vehicles used on public streets or highways is strictly prohibited in California and others states that have adopted California emission regulations.

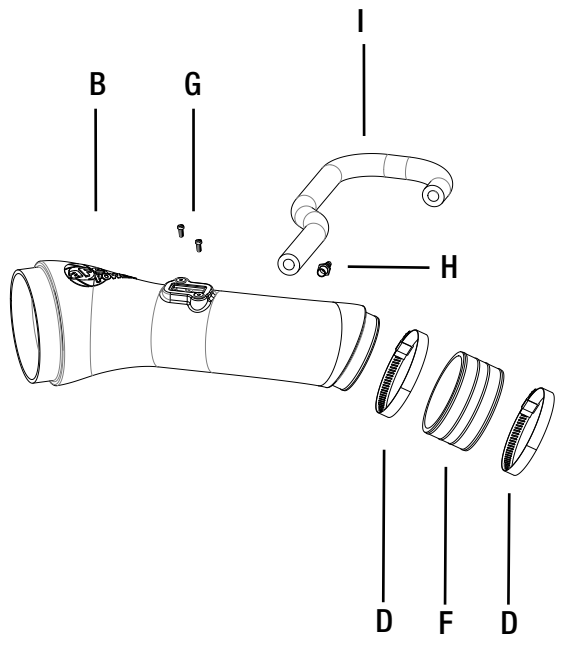
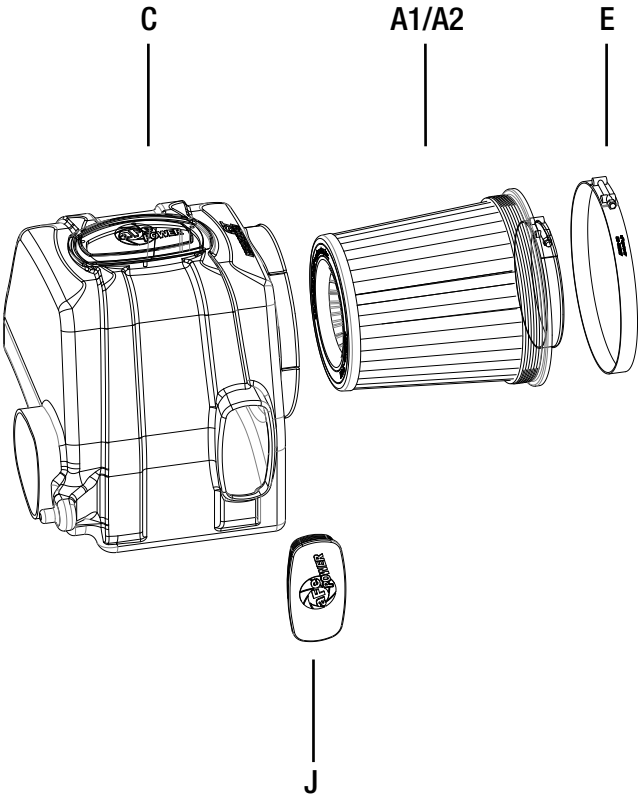



Figure A

Refer to Figure A for Step 1

Step 1: Remove engine cover by grasping sides and carefully lifting up.



Refer to Figure B for Step 2

Step 2: Unclip the wire harness tab from the factory airbox.

**Figure C****Refer to Figure C for Steps 3-8**

Step 3: Disconnect the mass air flow (MAF) sensor harness (1).

Step 4: Disconnect the vacuum line (smaller tube) from the intake factory tube (2).

Step 5: Remove the crank case vent (CCV) hose. *Optional: save the 2 factory spring clips for use later (3).

Step 6: With 10mm nut driver, loosen both bolts securing the housing to the fender well (4).

Step 7: With 10mm nut driver, loosen hose clamp on throttle body (5).

Step 8: Lift and remove factory intake system out of vehicle.

**Figure D****Refer to Figure D for Steps 9-10**

Step 9: Using a Phillips head screwdriver, remove the MAF sensor and transfer to the aFe intake tube.

Secure using the two provided flat head screws.

Step 10: Install brass hose fitting on aFe intake tube and tighten.



Figure E

Refer to Figure E for Step 11

Step 11: Remove and transfer the two rubber isolation mounts, and the large rubber grommet to aFe Momentum housing (6).



Figure F

Refer to Figure F for Step 12

Step 12: Before installing housing, insert the captive bolts into the rubber grommets from the inside as shown.



Figure G

Refer to Figure G for Steps 13-14

Step 13: Install aFe Momentum housing as shown. Tighten bolts on inside of housing using ¼” ratchet with 10mm socket. Do not over tighten.

Step 14: Install large t-bolt clamp as shown but do not tighten at this time.



Figure H

Refer to Figure H for Steps 15-17

Step 15: Install air filter into housing and tighten large t-bolt clamp (7).

Step 16: Slide smaller t-bolt clamp over filter flange as shown but do not tighten yet (8).

Step 17: Slide straight coupling over throttle body along with both band clamps as shown. Do not tighten band clamps yet (9).



Figure 1

Refer to Figure 1 for Step 18

Step 18: Insert aFe tube into Momentum filter as shown and rotate forward to line up with throttle body.

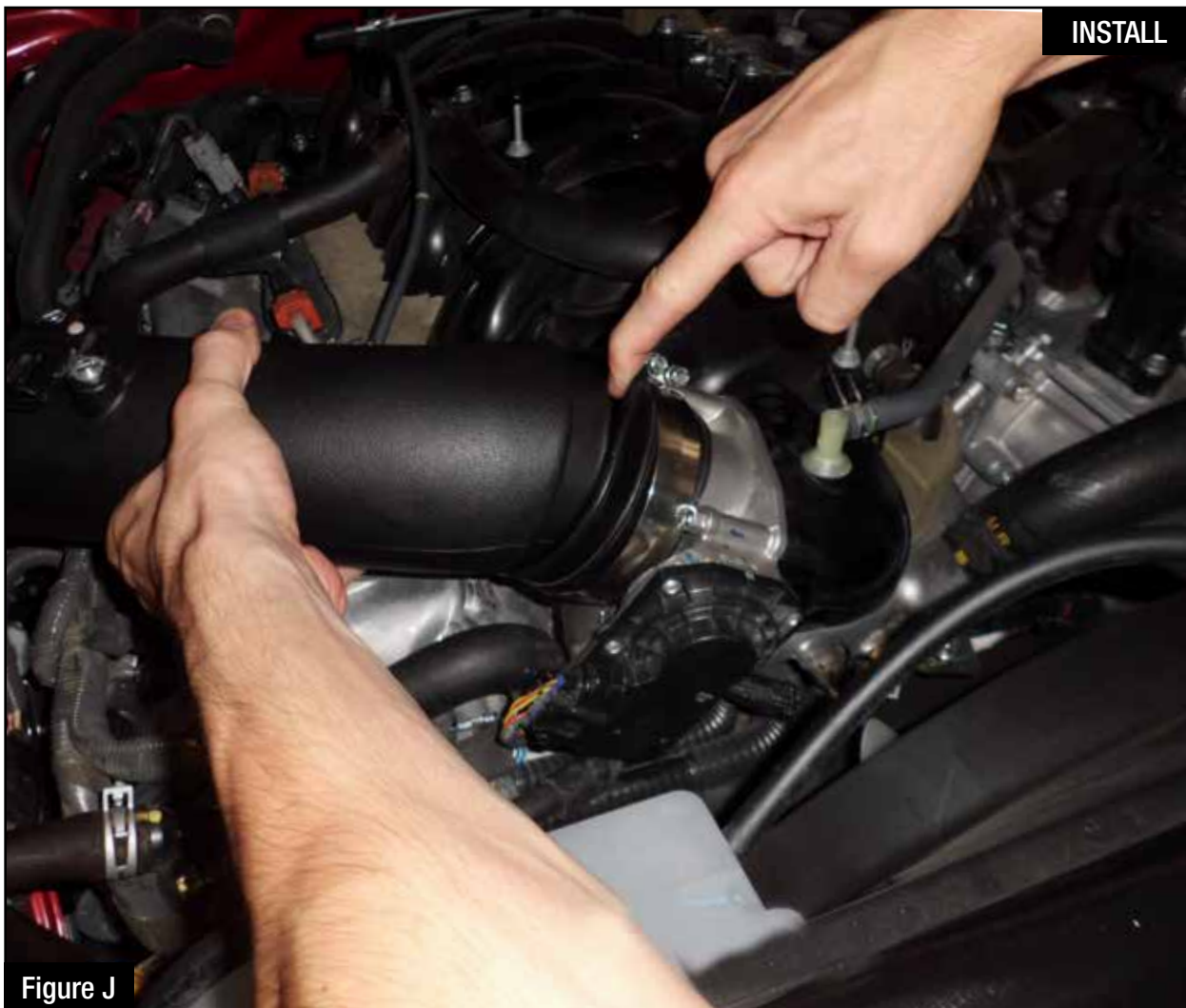

Figure J

Refer to Figure J for Steps 19-20

Step 19: With both band clamps loose, insert aFe tube into straight coupling as shown.

Step 20: Tighten both band clamps on throttle body and small t-bolt clamp on filter at this time.

**Figure K****Refer to Figure K for Steps 21-23**

Step 21: Slip metal hose clips over provided hose and install as shown (10).

Step 22: Reconnect vacuum line to brass fitting on the aFe tube (11).

Step 23: Reconnect MAF sensor as shown (12).



Figure L

Refer to Figure L for Steps 24-25

Step 24: Reinstall engine cover. Your installation is now complete!

Step 25: (Optional) install plug on side of housing.

*Verify all connections are secure 100-200 miles after installation



Pro DRY S Air Filter



P/N: 21-91072

Pro 5R Air Filter



P/N: 24-91072

Pro DRY S Restore Kit



P/N: 90-59999

Blue Squeeze Restore Kit



P/N: 90-50501

Blue Aerosol Restore Kit



P/N: 90-50001

aFe Cat-Back Exhaust



P/N: 49-46006-B

aFe Cat-Back Exhaust



P/N: 49-46008

aFe Cat-Back Exhaust



P/N: 49-46009-B

aFe Cat-Back Exhaust



P/N: 49-46014-B

aFe Throttle Body Spacer



P/N: 46-38005

aFe Power Hat



P/N: 40-10083

Warranty

General Terms:

- aFe warrants their products to be free from manufacturer's defects due to workmanship and material.
- This warranty applies only to the original purchaser of the product and is nontransferable.
- Proof of purchase of the aFe product is required for all warranty claims.
- Warranty is valid provided aFe instructions for installation and/or cleaning were properly followed.
- Proper maintenance with regular inspections of product is required to insure warranty coverage.
- Damage due to improper installation, abuse, unauthorized repair or alteration is not warranted.
- Incidental or consequential damages or cost, including installation and removal of part, incurred due to failure of aFe product is not covered under this warranty.
- All warranty is limited to the repair and/or replacement of the aFe part. To request Return Goods Authorization ("RGA"). Upon receipt of the RGA, you must return the product to the address provided in the RGA, freight prepaid and accompanied with a dated proof of purchase and the RGA. Upon receipt of the defective product and upon verification of proof of purchase, aFe will either repair or replace the defective product within a reasonable time, not to exceed thirty days.

Product Category	P/N Prefix	Warranty duration
Direct OE Replacement Filters	10, 11, 30, 31, 71, 73	Life of the vehicle
Racing Filters	18	1 year
Universal	21, 24, 72	2 years
Air Intake Systems	50, 51, 54, 55, 75	2 years
Exhaust Systems	49	2 years
Intercoolers & Intercooler Tubes	46-2	2 years
Intake Manifolds	46-1	2 years
Differential Cover	46-7	Life of the vehicle
Exhaust Manifolds	46	2 years
Throttle Body Spacers	46-3	2 years
Fluid Filters	44	90 days
Pre-Filters	28	2 years
Heavy Duty OE Replacement	70	2 years
PowerSports OE Replacement	81, 87	2 years
PowerSports Intake Systems	85	2 years

No other warranty expressed or implied applies nor is any person or advanced FLOW engineering authorized to assume any other warranty. Some States do not allow the exclusion or limitation of incidental or consequential damages or do not allow limitations on how long an implied warranty lasts, so the above limitations or exclusions may not apply to you. This warranty gives you specific legal rights, and you may also have other rights which vary from State to State.