

advanced FLOW engineering

Instruction Manual P/N: 51-74107 / 54-74107

Make: **Chevrolet / GMC** Model: **Colorado / Canyon** Year: **2015-2017** Engine: **I4-2.5L**



- Please read the entire instruction manual before proceeding.
- Ensure all components listed are present.
- If you are missing any of the components, call technical support.
- Ensure you have all necessary tools before proceeding.
- Do not attempt to work on your vehicle when the engine is hot.
- Disconnect both the negative battery terminal before proceeding.

Retain factory parts for future use.

Label	Qty.	Description	Part Number
A1	1	Pro 5R (Blue Media)	24-91092
A2	1	Pro DRY S (Grey Media)	21-91092
B	1	Tube	05-74107B1
C	1	Housing	05-74106B2
D	1	Plug, Urethane	05-01361
E	1	Seal Trim (7/16") (18 inches)	05-00072
F	2	Clamp, T-bolt (3-1/16" -3-3/8")	03-50320
G	1	Coupling, Silicone Elbow	05-01384
H	2	Screw, Torx: M4 x .7 x 8mm	03-50491
I	1	Fitting, Vent	05-01339

Installation will require the following tools:

10mm & 8mm nut drivers, pliers, T20 & T30 drivers, 11mm deep socket & driver, 20mm wrench or adjustable wrench.

Note: Not legal for use in California. The use of this device in any on-road or off-road vehicles registered with the California Dept of Motor Vehicles (DMV) is strictly prohibited.

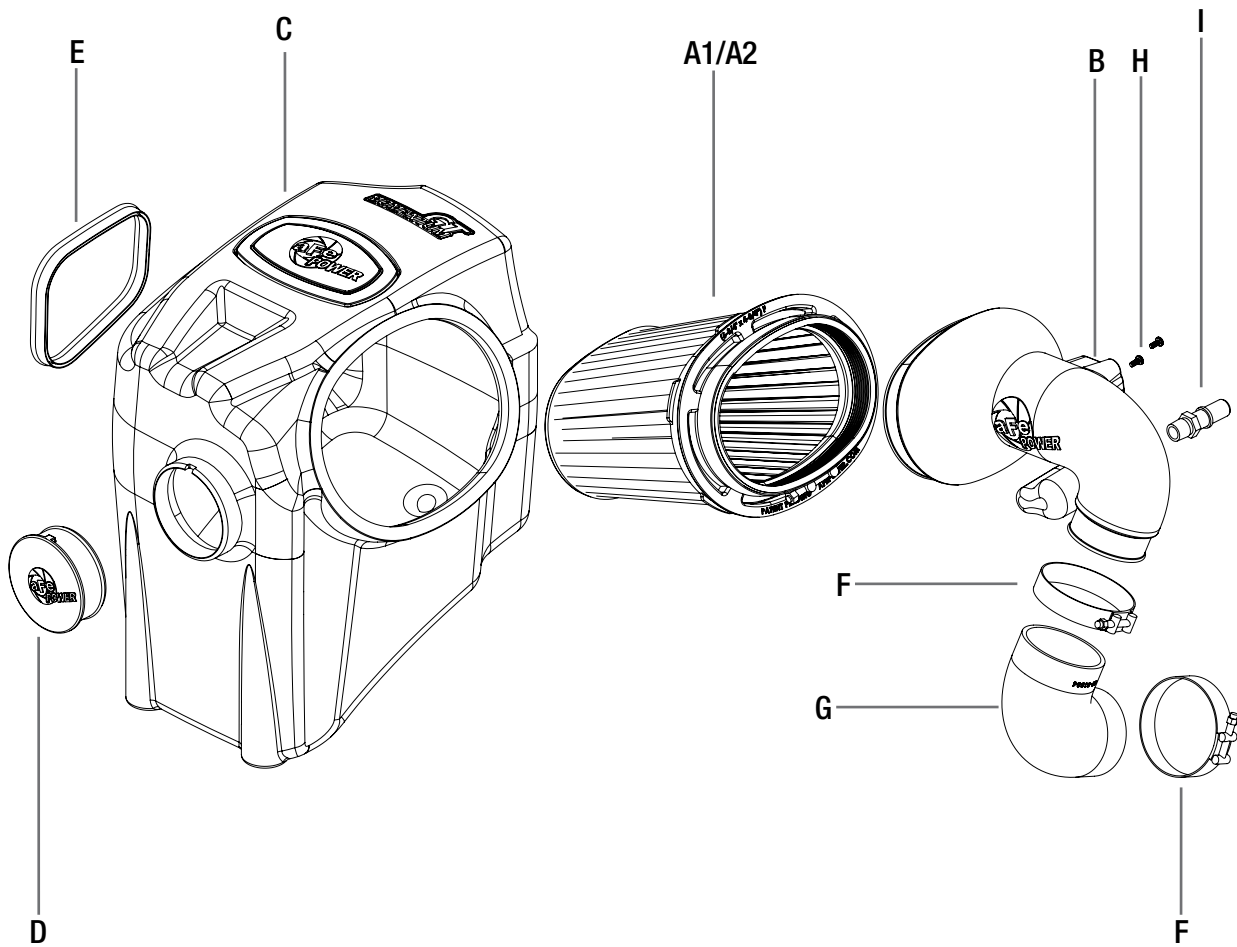



Refer to Figure A for Step 1

Step 1: Use an 8mm nut driver to loosen the stock clamps (1) at the throttle body and the air box. Disconnect the breather hose (2) from the intake tube. Use a T-30 driver to remove the screw (3) holding down the intake tube. Remove the intake tube.



Figure B

Refer to Figure B for Step 2

Step 2: Disconnect the mass air flow sensor (4). Disengage the wire loom clip (5) from the air box.

**Figure C****Refer to Figure C for Step 3**

Step 3: Use a 10mm nut driver to remove the two nuts ⑥ holding the air box and set aside. Remove the air box with the attached air inlet by pulling up to release air box from its mounting grommet.



Figure D

Refer to Figure D for Step 4

Step 4: Using a pair of pliers, rotate the coolant reservoir hose clamps so the ears point up.

**Figure E****Refer to Figure E for Steps 5-6**

Step 5: Using a Torx 20 driver, remove the mass air flow sensor (7) from the air box and install it on the aFe intake tube with the two supplied screws. Do not overtighten.

Step 6: Install the supplied aluminum vent fitting (8) into the aFe intake tube using a 20mm wrench or adjustable wrench.



Figure F

Refer to Figure F for Step 7

Step 7: Install the supplied trim seal on the opening of the aFe air box.

REMOVAL



Figure G

Refer to Figure G for Step 8

Step 8: Remove the two grommets with metal spacers from the lower half of the air box and install them onto the aFe air box.



Figure H

Refer to Figure H for Step 9

Step 9: Install the aFe air box into the vehicle by pushing down the air box pin into the rubber grommet and through the two front studs. Secure the air box with the two nuts removed in step 3 with a 10mm nut driver.



Figure 1

Refer to Figure 1 for Step 10

Step 10: Slide the aFe filter and clamp into the aFe housing and push it in until it locks into place. Do not tighten clamp at this time.



Figure J

Refer to Figure J for Step 11

Step 11: Place one of the supplied T-bolt clamp on the silicone elbow coupler and install them on the throttle body. Place the other supplied T-bolt clamp on the coupler. Do not tighten the clamps at this time.



Figure K

Refer to Figure K for Step 12

Step 12: Install the aFe intake tube into the vehicle. Slide into the coupler first. Then slide it into the filter. Align intake tube and coupler and tighten all clamps.



Figure L

Refer to Figure L for Step 13

Step 13: Re-connect the mass air flow sensor (9) and the breather hose (10) .

**Figure M****Refer to Figure M for Step 14**

Step 14: Use the provided plug (11) to close additional air inlet if you want to completely seal the air box. Best performance gain is obtained by having more flow (no plug). Check all the components are tight and secure. Your installation is now complete.

NOTE: Check all bolts, clamps, and connectors after 200 miles.



Pro DRY S Air Filter



P/N: 21-91092

Pro 5R Air Filter



P/N: 24-91092

Pro DRY S Restore Kit



P/N: 90-59999

Blue Squeeze Restore Kit



P/N: 90-50501

Pre-Filter



P/N: 28-10283

Throttle Body Spacer



P/N: 46-34014

Exhaust Cat-Back



P/N: 49-44058-B (w/ Blk Tip)
49-44058-P (w/ Pol Tip)

Side Exit Exhaust



P/N: 49-44061-B (w/ Blk Tip)
49-44061-P (w/ Pol Tip)

Rear Shocks



P/N: 502-0052-02

Front Coilovers



P/N: 501-5600-03

Warranty

General Terms:

- aFe warrants their products to be free from manufacturer's defects due to workmanship and material.
- This warranty applies only to the original purchaser of the product and is non-transferrable.
- Proof of purchase of the aFe product is required for all warranty claims.
- Warranty is valid provided aFe instructions for installation and/or cleaning were properly followed.
- Proper maintenance with regular inspections of product is required to insure warranty coverage.
- Damage due to improper installation, abuse, unauthorized repair or alteration is not warranted.
- Incidental or consequential damages or cost, including installation and removal of part, incurred due to failure of aFe product is not covered under this warranty.
- All warranty is limited to the repair and/or replacement of the aFe part. To request Return Goods Authorization ("RGA"). Upon receipt of the RGA, you must return the product to the address provided in the RGA, freight prepaid and accompanied with a dated proof of purchase and the RGA. Upon receipt of the defective product and upon verification of proof of purchase, aFe will either repair or replace the defective product within a reasonable time, not to exceed thirty days.

Product Category	P/N Prefix	Warranty duration
Direct OE Replacement Filters	10, 11, 30, 31, 71, 73	Life of the vehicle
Racing Filters	18	1 year
Universal	21, 24, 72	2 years
Air Intake Systems	50, 51, 54, 55, 75	2 years
Exhaust Systems	49	2 years
Intercoolers & Intercooler Tubes	46-2	2 years
Intake Manifolds	46-1	2 years
Differential Cover	46-7	Life of the vehicle
Exhaust Manifolds	46	2 years
Throttle Body Spacers	46-3	2 years
Fluid Filters	44	90 days
Pre-Filters	28	2 years
Heavy Duty OE Replacement	70	2 years
PowerSports OE Replacement	81, 87	2 years
PowerSports Intake Systems	85	2 years

No other warranty expressed or implied applies nor is any person or advanced FLOW engineering authorized to assume any other warranty. Some States do not allow the exclusion or limitation of incidental or consequential damages or do not allow limitations on how long an implied warranty lasts, so the above limitations or exclusions may not apply to you. This warranty gives you specific legal rights, and you may also have other rights which vary from State to State.