

HD
MOMENTUM™

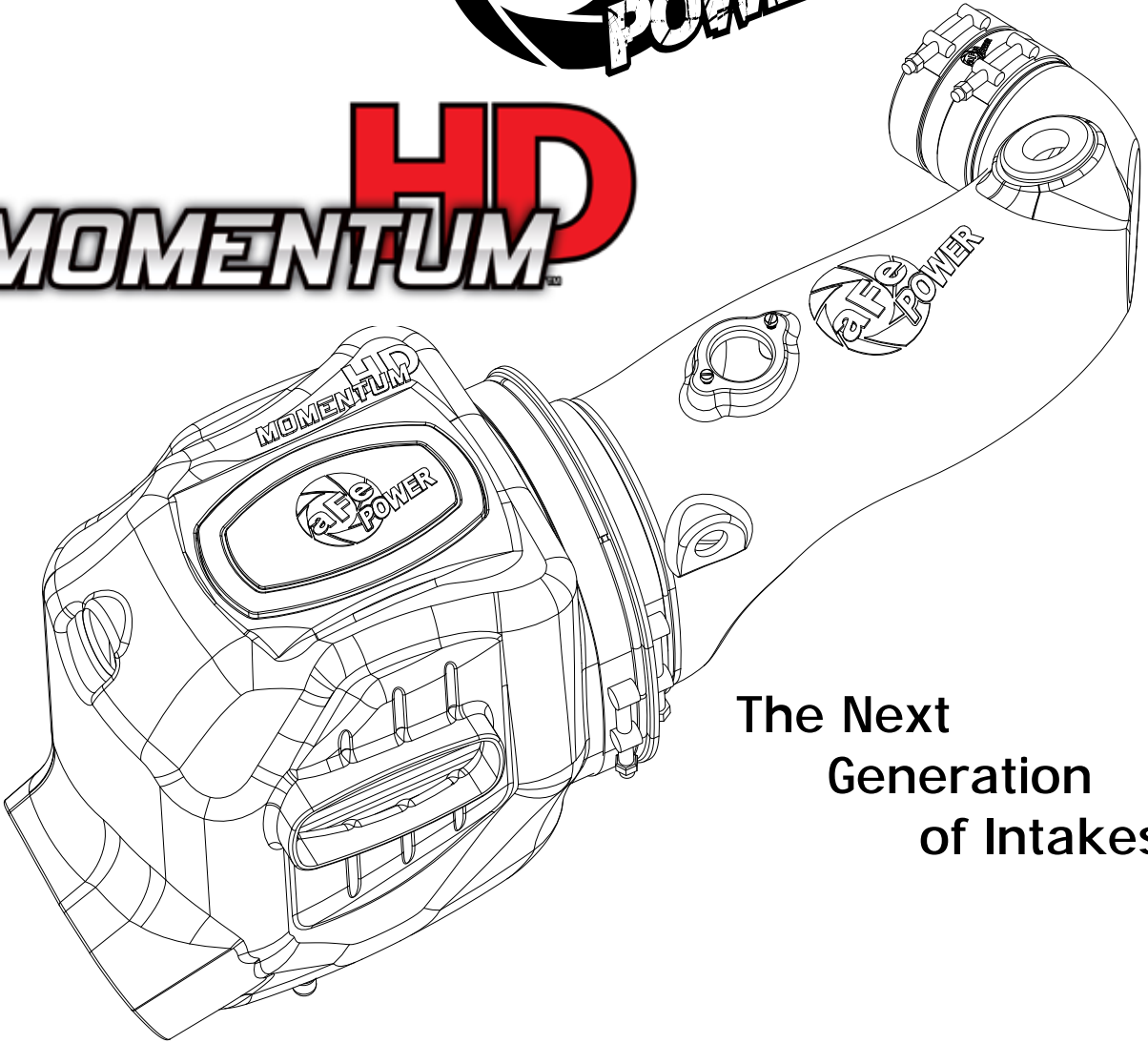

**The Next
Generation
of Intakes**

advanced FLOW engineering

Instruction Manual P/N: 51-73004/54-73004/75-73004

Make: **FORD** Model: **F-250/350/450/550** Year: **2008-2010** Engine: **V8-6.4L (td)**



- Please read the entire instruction manual before proceeding.
- Ensure all components listed are present.
- If you are missing any of the components, call technical support.
- Ensure you have all necessary tools before proceeding.
- Do not attempt to work on your vehicle when the engine is hot.
- Disconnect both the negative battery terminal before proceeding.
- Retain factory parts for future use.

Label	Qty.	Description	Part Number
A	1	Housing	05-73004B2-S
B	1	Plug, Urethane	05-01202
C	1	Clamp, T-bolt (8-5/16")	03-50267
D1	1	PRO 5R (Blue Media)	24-91061
D2	1	PRO DRY S (Grey Media)	21-91061
D3	1	PRO-GUARD 7 (Yellow Media)	72-91061
E	2	Screw, M4	03-50221
F	1	Tube	05-73004B1
G	1	Clamp, Mini	03-50023
H	1	Fitting, Elbow	03-50178
I	1	Grommet, Rubber	03-50139
J	2	Clamp, T-bolt (3")	03-50320
K	1	Coupling, Silicone Hump	05-01245
L	1	T20 Torx Bit	03-50066

Installation will require the following tools:

1/4" Nut Driver, 5/16" or 8mm Nut Driver, Wire Cutters, Flat Head Screw driver, 10mm and 7/16" Socket, Ratchet and Extension.

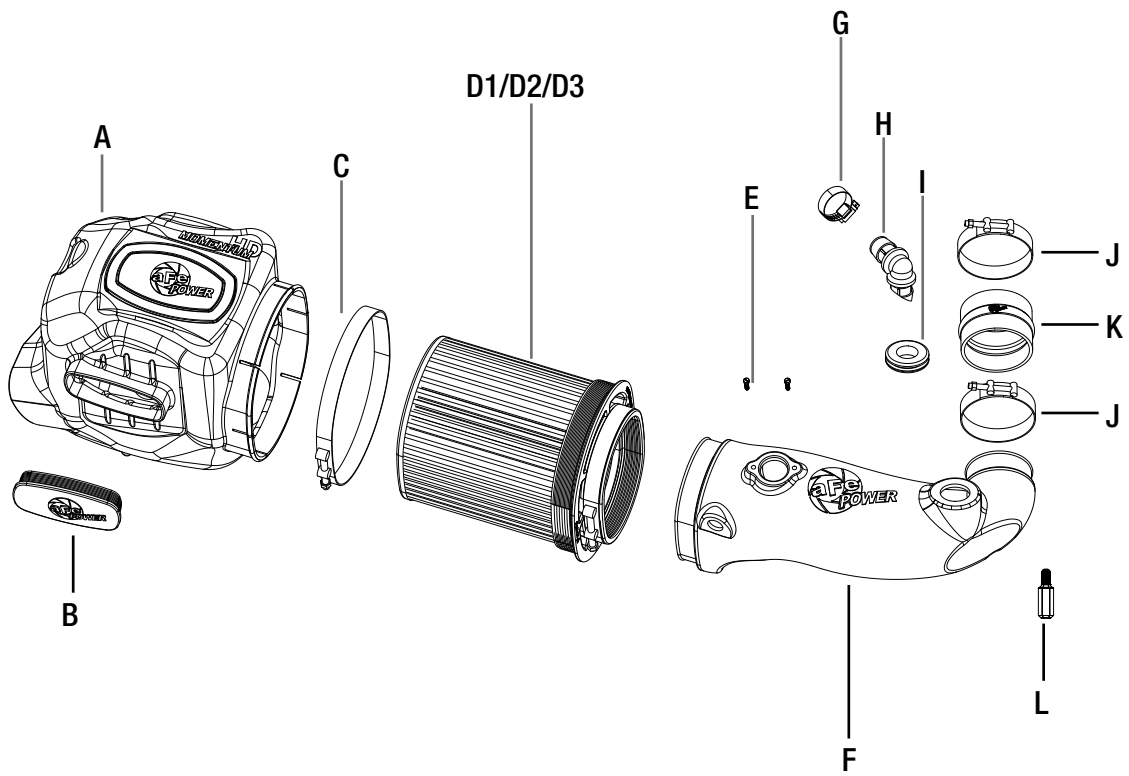



Refer to Figure A for steps 1-6

Step 1: Disconnect both batteries.

Step 2: Loosen the (2) Intake tube clamps using an 8mm nut driver.

Step 3: Disconnect the wire harness (1) from the Mass Air Flow (MAF) sensor.

Step 4: Disconnect the wire harness (2) from the filter minder.

Step 5: Remove the crank case breather hose clamp by prying it open with a screw driver or cutting it. Then pull the crank case breather hose from the intake tube.

Step 6: Remove the factory intake tube out of the vehicle. Take the auxiliary air line out of the factory air box. Remove the factory air box by pulling it firmly out of the factory grommets.



Figure B

Refer to Figure B for step 7

Step 7: Install the filter (D) in the Momentum HD housing (A) and install the large T-bolt clamp (C).
Install the medium T-bolt clamp (D) on the filter. Do not tighten yet.

IMPORTANT: Prior to installation of T-bolt clamp, we recommend that you form the T-bolt clamps by installing it in its intended position and tightening.

**Figure C****Refer to Figure C for steps 8-12**

Step 8: Remove the MAF sensor and filter minder with rubber grommet (Will be reused) from the factory air intake.

Step 9: Install the factory filter minder grommet and filter minder onto the Momentum HD intake tube.

Step 10: Install the MAF sensor into the Momentum HD intake tube using the provided screws (E).

Step 11: Install supplied rubber grommet (I) onto the intake tube (F) for the crank case breather.

Step 12: Install supplied coupling (K) to the intake tube. (Do not install the clamps at this time).



Figure D

Refer to Figure D for step 13

Step 13: Place the Momentum HD housing in the truck. DO NOT push it completely into its final location.

**Figure E****Refer to Figure E for steps 14-15**

Step 14: Connect the Momentum HD tube to the turbo. Leave the tube at a 45-degree angle.

Step 15: **PLEASE READ CAREFULLY:** Rotate the intake tube down into the filter and at the same time you will need to push the housing into the factory grommets. When secure in the grommets, the tube will fit into the filter. Install the auxiliary air line into the housing (4).



Refer to Figure F for steps 16-17

Step 16: Install the (2) supplied T-bolt clamps (J) over the coupling at the turbo, and tighten. Also tighten the T-bolt clamps on the filter and on the housing.

Step 17: Install the crank case breather hose into the rubber grommet on the Momentum HD intake tube. Early models (built before 5/6/2007) 90-degree fitting can be reused. For later model (built after 5/7/2007) production tubes, cut or pry the upper clamp off and use the provided plastic 90-degree fitting (H) & mini clamp supplied (G).



Refer to Figure G for steps 18-20

Step 18: Reconnect the harness to the MAF sensor and the Filter Minder.

Step 19: Check all components are tight and secured.

Step 20: Tighten all clamps and re-connect the batteries. Your installation is now complete.

Use the furnished plug (B) to close off the front auxiliary air inlet to completely seal the airbox.

NOTE: Retighten all connections after approximately 100-200 miles.

Place the included CARB EO sticker on or near the device on a smooth, clean surface. EO identification label is required to pass the Smog Check Inspection.



Air Filter



PRO 10R P/N: 20-91061
PRO DRY S P/N: 21-91061
PRO 5R P/N: 24-91061
PRO-GUARD 7 P/N: 72-91061

Pre-Filter



P/N: 28-10283

Blue Aerosol Restore Kit



P/N: 90-50001

Blue Squeeze Restore Kit



P/N: 90-50501

aFe Power Diesel T-Shirt



P/N: 40-30222 (L)
P/N: 40-30223 (XL)
P/N: 40-30224 (2XL)
P/N: 40-30225 (3XL)

aFe Power Hat



P/N: 40-10114 (S/M)
P/N: 40-10115 (L/XL)

aFe Power Ladies Hat



P/N: 40-10112

aFe Power Backpack



P/N: 40-33203

Warranty

General Terms:

- aFe warrants their products to be free from manufacturer's defects due to workmanship and material.
- This warranty applies only to the original purchaser of the product and is non-transferrable.
- Proof of purchase of the aFe product is required for all warranty claims.
- Warranty is valid provided aFe instructions for installation and/or cleaning were properly followed.
- Proper maintenance with regular inspections of product is required to insure warranty coverage.
- Damage due to improper installation, abuse, unauthorized repair or alteration is not warranted.
- Incidental or consequential damages or cost, including installation and removal of part, incurred due to failure of aFe product is not covered under this warranty.
- All warranty is limited to the repair and/or replacement of the aFe part. To request Return Goods Authorization ("RGA"). Upon receipt of the RGA, you must return the product to the address provided in the RGA, freight prepaid and accompanied with a dated proof of purchase and the RGA. Upon receipt of the defective product and upon verification of proof of purchase, aFe will either repair or replace the defective product within a reasonable time, not to exceed thirty days.

Product Category	P/N Prefix	Warranty duration
Direct OE Replacement Filters	10, 11, 30, 31, 71, 73	Life of the vehicle
Racing Filters	18	1 year
Universal	21, 24, 72	2 years
Air Intake Systems	50, 51, 54, 55, 75	2 years
Exhaust Systems	49	2 years
Intercoolers & Intercooler Tubes	46-2	2 years
Intake Manifolds	46-1	2 years
Differential Cover	46-7	Life of the vehicle
Exhaust Manifolds	46	2 years
Throttle Body Spacers	46-3	2 years
Fluid Filters	44	90 days
Pre-Filters	28	2 years
Heavy Duty OE Replacement	70	2 years
PowerSports OE Replacement	81, 87	2 years
PowerSports Intake Systems	85	2 years

No other warranty expressed or implied applies nor is any person or advanced FLOW engineering authorized to assume any other warranty. Some States do not allow the exclusion or limitation of incidental or consequential damages or do not allow limitations on how long an implied warranty lasts, so the above limitations or exclusions may not apply to you. This warranty gives you specific legal rights, and you may also have other rights which vary from State to State.

Feel the difference with aFe.

Buy quality performance air intake systems in our online store.