

**ST**  
**MOMENTUM**

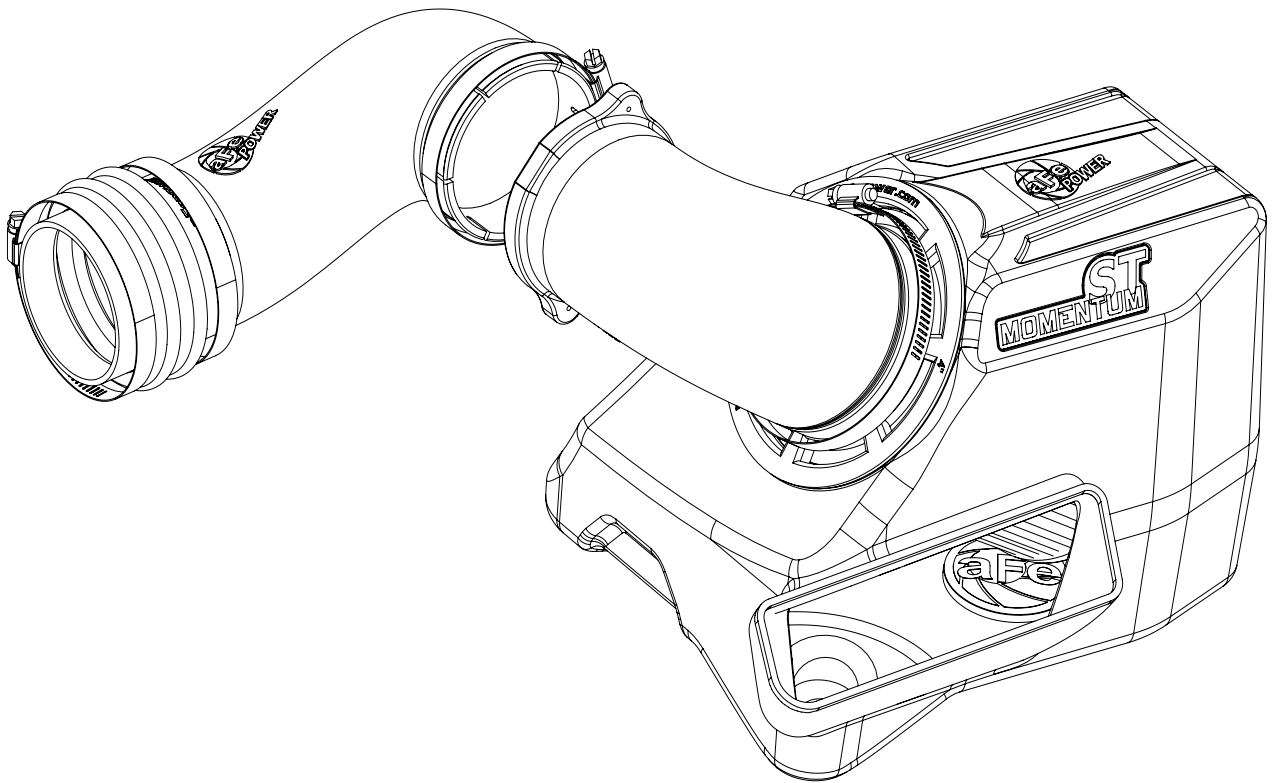

**advanced FLOW engineering** Momentum ST Air Intake

**Instruction Manual** P/N: 51-46405 / 54-46405

Make: **VW**

Model: **Atlas**

Year: **2018**

Engine: **V6-3.6L**

Note: **Includes 4Motion (AWD) models.**



- Please read the entire instruction manual before proceeding.
- Ensure all components listed are present.
- Ensure you have all necessary tools before proceeding.
- Do not attempt to work on your vehicle when the engine is hot.
- Disconnect the negative battery terminal before proceeding.
- Retain factory parts for future use.

Label	Qty.	Description	Part Number
A1	1	Air Filter (Pro DRY S)	21-91108
A2	1	Air Filter (Pro 5R)	24-91108
B	1	Tube #1 of 2	05-46405B1
C	1	Tube #2 of 2	05-46405B2
D	1	Housing	05-46405B3
E	1	Coupling, Silicone Bellow	05-01480
F	2	Clamp, #048	03-50007
G	1	Clamp, #056	03-50009
H	1	Plug, Airbox	05-01482

**Installation will require the following tools:**

7mm nut driver, 8mm nut driver and T25 torx driver.

Note: Legal in California for use on race vehicles only. The use of this device on vehicles used on public streets or highways is strictly prohibited in California and others states that have adopted California emission regulations.

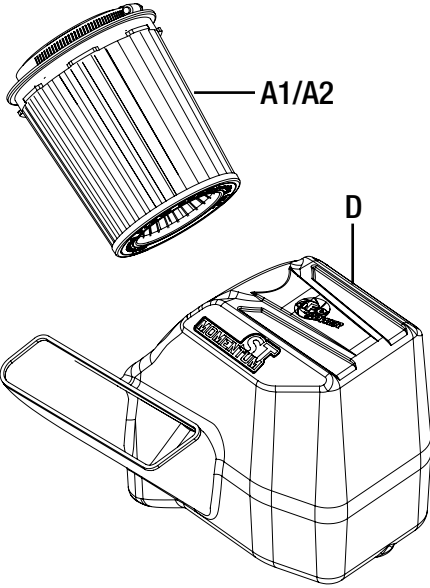
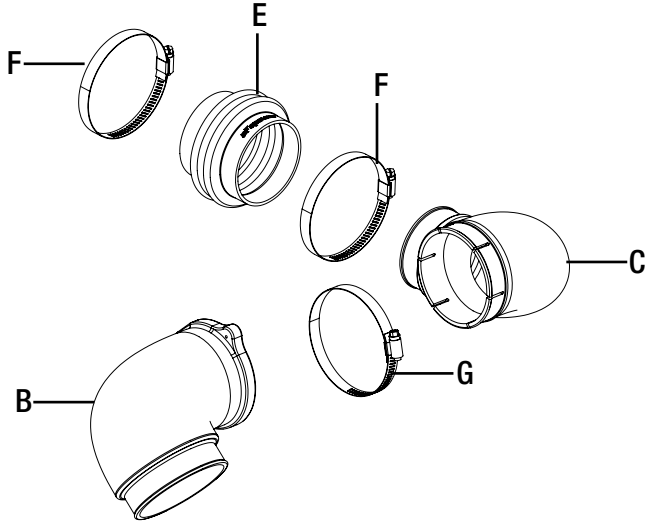



Figure A

**Refer to Figure A for Step 1.**

**IMPORTANT! During this process, leave the key outside of the vehicle.**

Step 1: Open the hood of the vehicle and let sit for 5 min to allow computer to fully shut down.



Figure B

**Refer to Figure B for Step 2.**

Step 2: Unplug the MAF connector (1) by pulling the back the tab of the connector. Now press down on the tab, and pull on the connector at the same time and the connector should come out.



**Refer to Figure C for Step 3.**

Step 3: Using a T25 torx driver, remove the two screws ② holding the stock scoop. Remove the scoop by pushing it back towards the engine then pulling up towards the hood.



Figure D

**Refer to Figure D for Steps 4.**

Step 4: Remove the rubber trim (3) on the stock airbox and transfer it over onto the scoop you removed in the previous step.

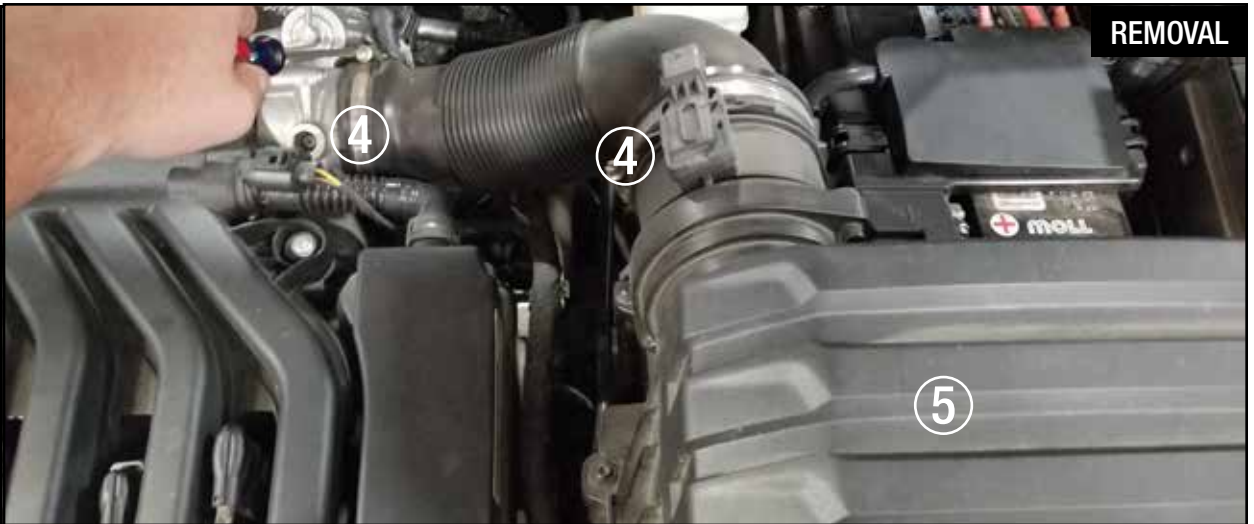

**Refer to Figure E for Steps 5-6**

Step 5: Loosen the clamps (4) on both ends of the stock intake tube with a 7mm nut driver. Remove the tube from the vehicle.

Step 6: Remove the stock airbox (5) from the vehicle by pulling up on the rear most mounting point and slowly freeing the other two mounting points.



**Figure F****Refer to Figure F for Step 7.**

Step 7: Remove the MAF cartridge (6) from the stock airbox by removing the two screws (7) with a T25 torx driver.



**Refer to Figure G for Step 8.**

Step 8: Slip the MAF cartridge (8) into the shorter aFe intake tube (9), align the sensor with the flat part of the flange and use the two screws you removed in the previous step to secure the cartridge to the tube.



Figure H

**Refer to Figure H for Step 9.**

Step 9: Transfer the three grommets (10) from the stock airbox over to the aFe POWER housing (11).



INSTALL



Figure I

**Refer to Figure I for Step 10.**

Step 10: Install the aFe POWER housing into the vehicle and install the filter (12) into the housing. Use the provided plug to close the additional air inlet if you want to completely seal the housing.

**NOTE: Best performance gain is obtained by having more air flow (No plug). However, having the plug installed will lower engine noise coming from the housing.**



Figure J

**Refer to Figure J for Step 11.**

Step 11: Install the stock scoop you removed earlier and use the original hardware to re-mount it to the vehicle.



Figure K

**Refer to Figure K for Steps 12-14.**

- Step 12: Slip the provided bellows coupling (13) and one #048 clamp (14) onto the throttle body and fully tighten the clamp with an 8mm nut driver.
- Step 13: Now install the longer aFe intake tube (15) into the other end of the bellows coupling (16) with the other #048 clamp (17). Tighten the clamp enough so the tube can rotate back and forth, but will NOT to pull out of the coupler.
- Step 14: Install the provided #056 (18) clamp onto the other end of the longer intake tube.



Figure L

**Refer to Figure L for Step 15.**

Step 15: Install the shorter aFe POWER intake tube (19) with the attached MAF cartridge into the filter (20). Now slip the other side of the MAF into the second half of the tube (21).



Figure M

**Refer to Figure M for Steps 16-18.**

Step 16: Position the longer intake tube (22) to where the cartridge sits flush against the lip of the tube and tighten the #056 clamp (23).

Step 17: Tighten all clamps down and ensure that the MAF cartridge (24) is secured.

Step 18: Reconnect the MAF sensor plug (25) and push the tab back in to lock the sensor.



INSTALL



Figure N

**Refer to Figure N for Step 19.**

Step 19: Once again, check that all clamps, connections and screws are tight. Your installation is now complete! Thank you for choosing aFe POWER!

**NOTE: Check all bolt, clamps, and connectors after 100-200 miles.**

Rely on premium performance air intake systems by aFe if you're looking for quality and efficiency.