

advanced FLOW engineering

Instruction Manual P/N: 51-12942-B / 54-12942-B

Make: **Ford** Model: **Super Duty F-250/F-350** Year: **2017-2018** Engine: **V8-6.2L**



- Please read the entire instruction manual before proceeding.
- Ensure all components listed are present.
- Ensure you have all necessary tools before proceeding.
- Do not attempt to work on your vehicle when the engine is hot.
- Disconnect the negative battery terminal before proceeding.
- Retain factory parts for future use.

Label	Qty.	Description	Part Number
A1	1	Pro DRY S Air Filter (Gray Media)	21-91065
A2	1	Pro 5R Air Filter (Blue Media)	24-91065
B	1	Tube	05-12942B1
C	1	Housing	05-12942B2
D	1	Coupling, Silicone Hump	05-01264
E	1	Vent Fitting, 5/8"	05-01354
F	2	Clamp, #052	03-50008
G	2	Hose, Fuel: 3/8" (9" inches)	05-00110
H	1	Seal, Trim: 7/16" (34.5" inches)	05-00072
I	1	Hose, Fuel: 5/8" (6" inches)	05-00069
J	3	Clamp, Mini #004	03-50097
K	2	Clamp, Mini #010	03-50078
L	1	Vent Fitting, 3/8"	05-60508

Installation will require the following tools:
1/4" & 8mm Nut Driver or socket and extension and pliers.

Note: Legal in California for use on race vehicles only. The use of this device on vehicles used on public streets or highways is strictly prohibited in California and others states that have adopted California emission regulations.

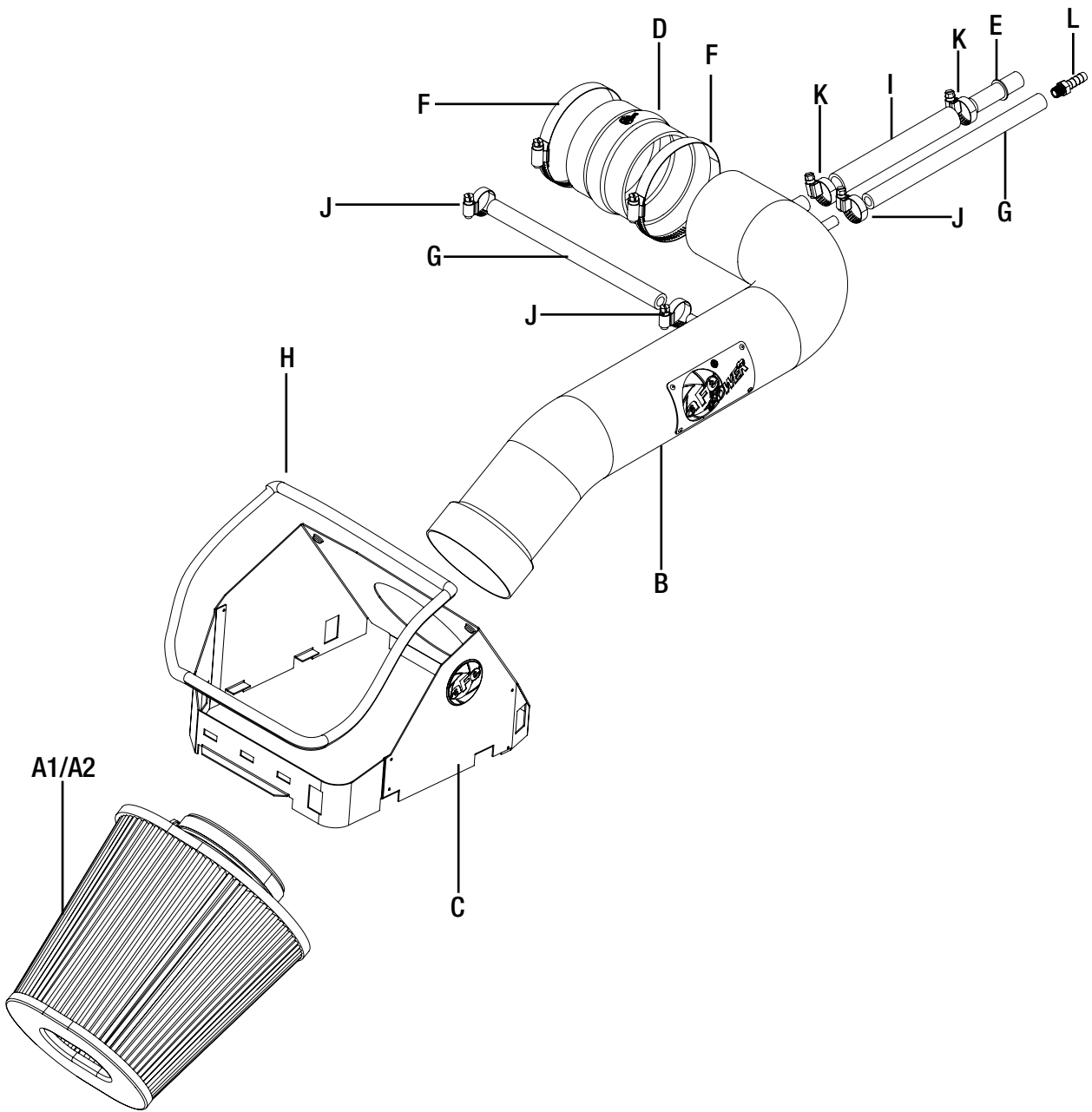

**Figure A****Refer to Figure A for Step 1**

Step 1: Remove the ④ latches securing the OE filter housing top, and loosen the two clamps on the OE tube.



Refer to Figure B for Step 2

Step 2: Disconnect the (3) vent hoses from the OE tube, making sure the passenger side hose is disconnected at the white plastic tee fitting.



Figure C

Refer to Figure C for Step 3

Step 3: Remove the OE tube, filter and top cover from the vehicle.

INSTALL



Figure D

Refer to Figure D for Step 4

Step 4: Install trim seal onto Magnum Force Stage 2 housing.



Figure E

Refer to Figure E for Step 5

Step 5: Install small vent tube adapter halfway into one of the supplied 3/8" vent hose.

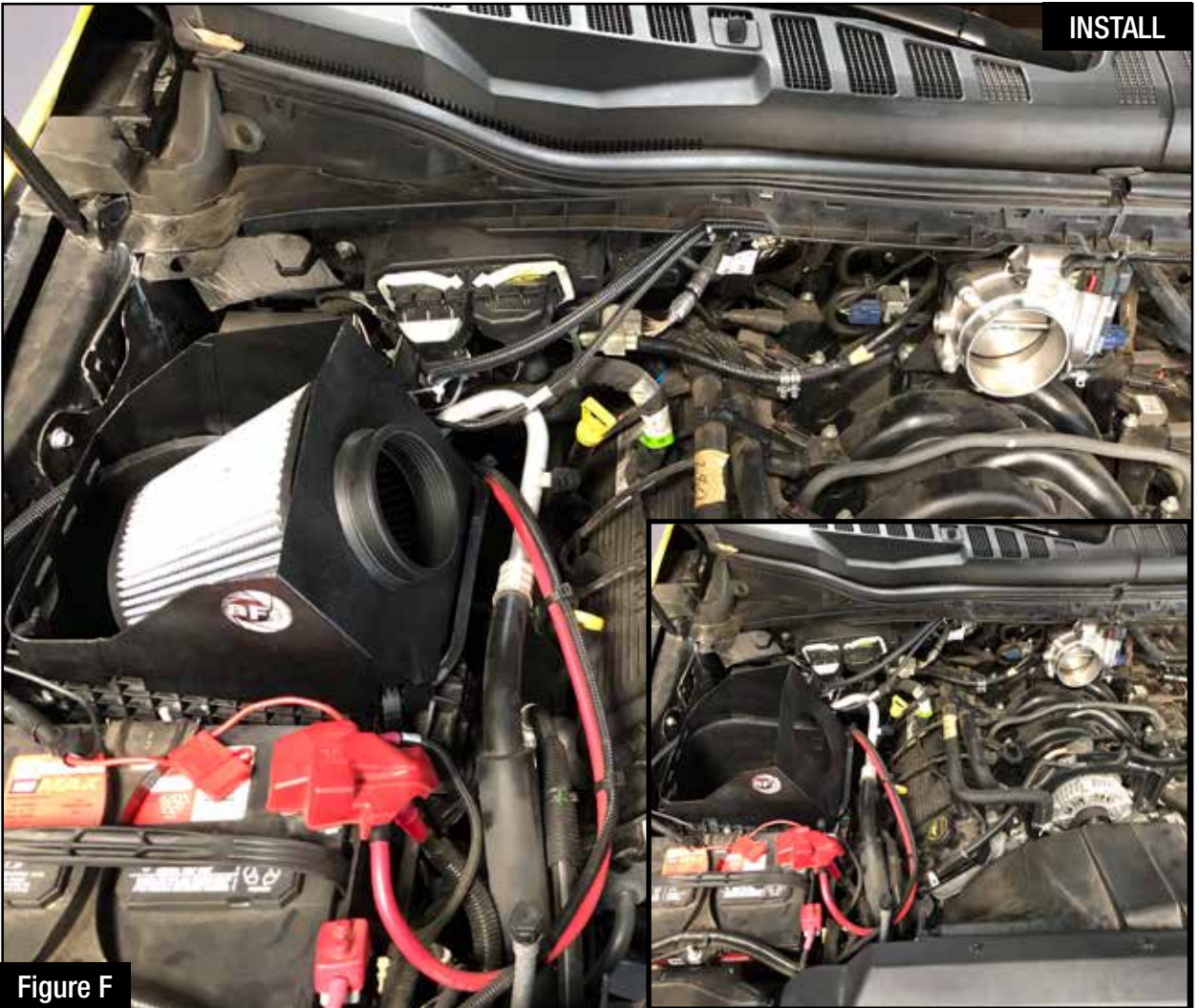

Figure F

Refer to Figure F for Steps 6-7

Step 6: Install the Magnum Force Stage 2 housing onto the OE air box by using the (4) factory latches.

Step 7: Install air filter from inside the housing and place hose clamp into the filter, but do NOT tighten.



Refer to Figure G for Step 8

Step 8: Install coupling and clamps onto the throttle body. Do not tighten clamps.



Figure H

Refer to Figure H for Step 9

Step 9: Install the 5/8" aluminum quick connect adapter into the OE quick connect vent hose.



INSTALL

Figure I

Refer to Figure I for Step 10

Step 10: Secure the 3/8" hose and plastic adapter to the driver's side 3/8" vent hose using the OE spring clamp.

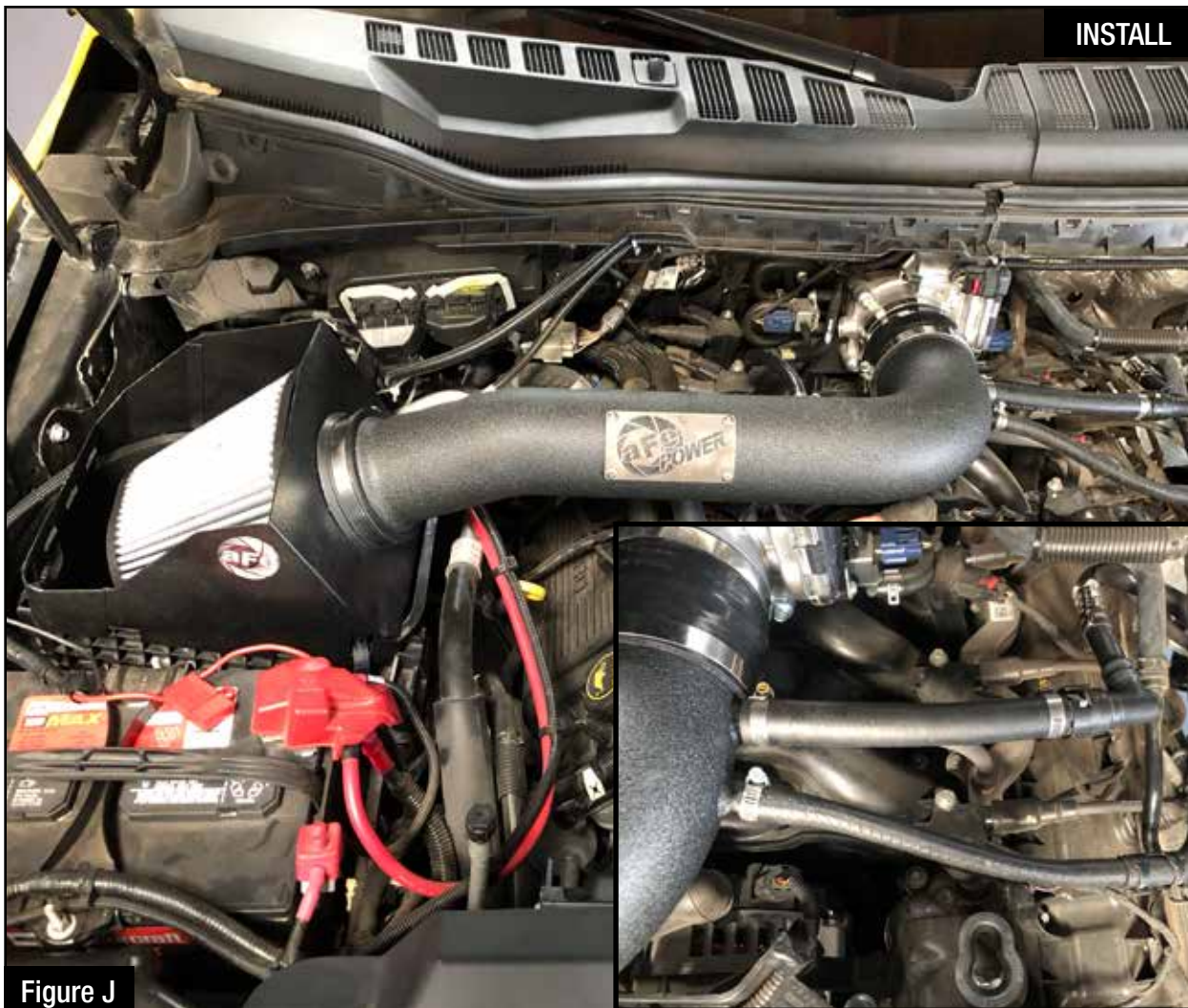

Figure J

Refer to Figure J for Steps 11-13

Step 11: Install Magnum Force Stage 2 tube by first sliding it into the filter and then the throttle body coupling and tighten clamps.

Step 12: Install the 5/8" hose onto the quick connect adapter and the intake tube fitting using the supplied hose clamps.

Step 13: Install drivers side 3/8" vent hose to intake tube fitting using supplied hose clamp.

INSTALL



Figure K

Refer to Figure K for Step 14

Step 14: Install the provided 3/8" hose onto the passenger side intake tube fitting and the white plastic tee fitting. Secure ends with the two provided mini clamps.

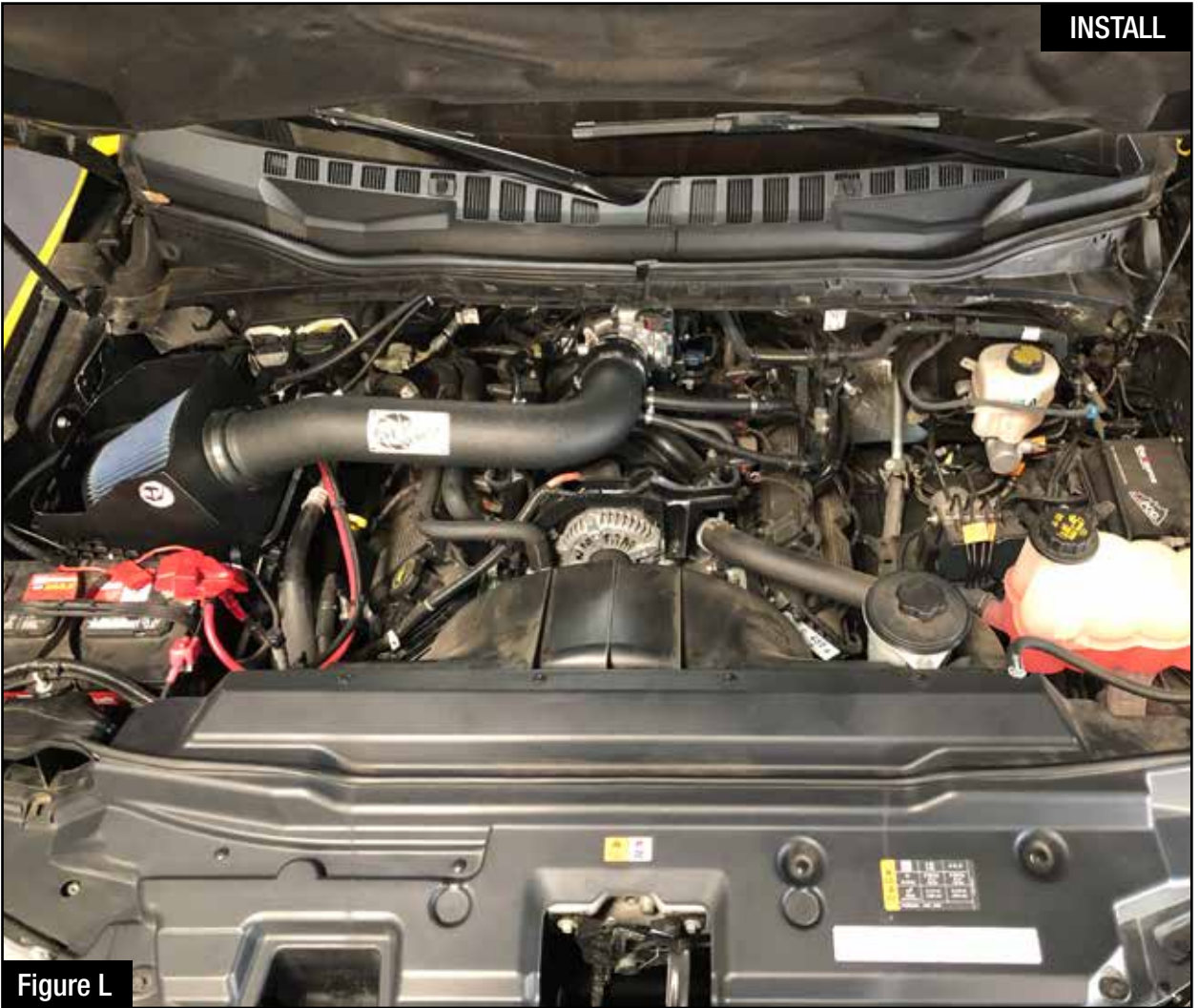

Figure L

Refer to Figure L for Step 15

Step 15: Check all connections are secure. Your installation is now complete.

NOTE: Check all bolts, clamps, and connectors after 100-200 miles.



Pro DRY S Air Filter



P/N: 21-91065

Pro 5R Air Filter



P/N: 24-91065

Pro DRY S Restore Kit



P/N: 90-59999

Blue Squeeze Restore Kit



P/N: 90-50501

Intake Cover



P/N: 54-12948-B

Sprint Booster V3.



P/N: 77-13001

Cat-Back Exhaust



P/N: 49-43086-B (Blk. Tip)
49-43086-P (Pol. Tip)

Transmission Pan



P/N: 46-70180 (RAW)
46-70182 (Blk./Mach)