

GT
MOMENTUM™

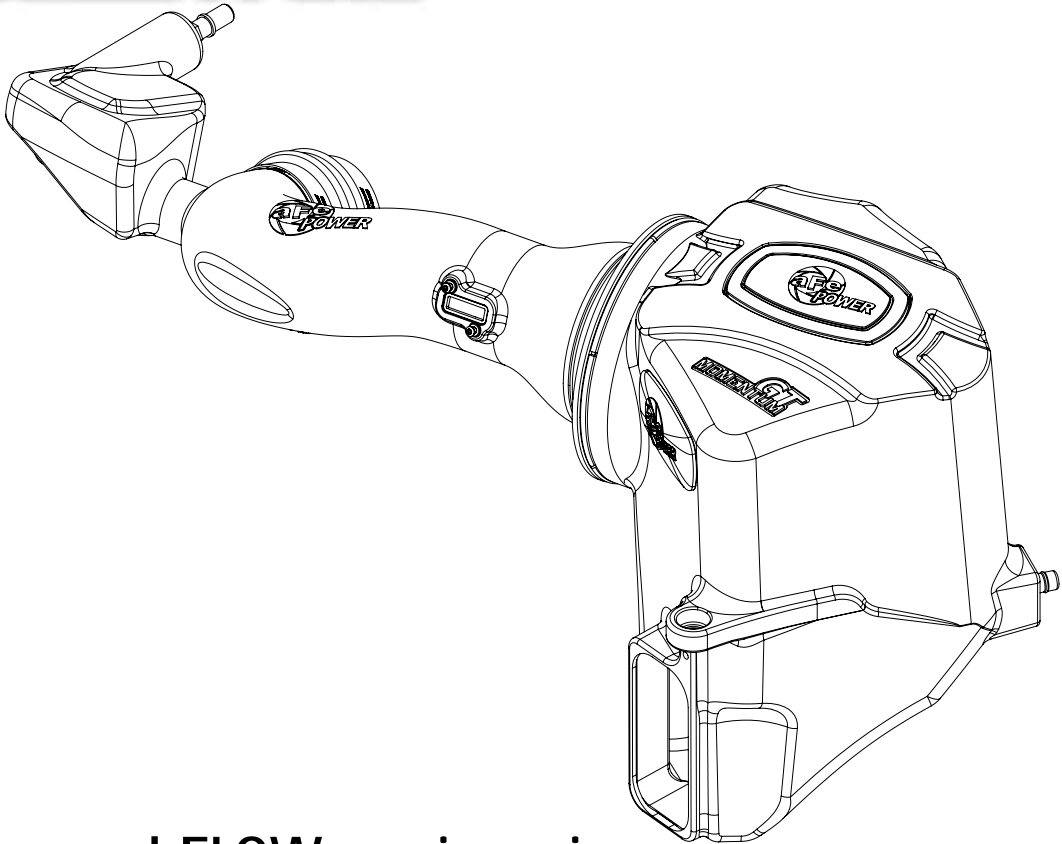

advanced FLOW engineering Momentum GT Cold Air Intake System

Instruction Manual P/N: 50-70044D / 50-70044R

Make: **Chevrolet** Model: **Silverado 1500**

Year: **2019**

Engine: **V6-4.3L/V8-5.3L/6.2L**

Make: **GMC** Model: **Sierra 1500**

Year: **2019**

Engine: **V6-4.3L/V8-5.3L/6.2L**



- Please read the entire instruction manual before proceeding.
- Ensure all components listed are present.
- If you are missing any of the components.
- Ensure you have all necessary tools before proceeding.
- Do not attempt to work on your vehicle when the engine is hot.

Retain factory parts for future use.

Label	Qty.	Description	Part Number
A1	1	Air Filter (Pro 5R)	24-91147
A2	1	Air Filter (Pro DRY S)	21-91147
B	1	Tube	05-5070044B1
C	1	Housing	05-5070044B2
D	1	Coupling, Silicone Bellow: 3-3/4"IDx3"L	05-01509
E	1	Coupling, Silicone Bellow: (3-1/2"x3-3/4")IDx3"L	05-01508
F	1	Coupling, Silicone Bellow: (3.75"x3")IDx4.75"L	05-01510
G	2	Clamp, T-bolt (3-13/16" - 4-1/8")	03-50265
H	1	Clamp, T-bolt (3-9/16" - 3-7/8")	03-50498
I	1	Clamp, T-bolt (3-1/16" - 3-3/8")	03-50320
J	2	Screw, Torx: M4	03-50491
K	1	Fitting, Vent Tube	05-01339
L	1	Clamp, T-bolt (8-5/16" - 8-5/8")	03-50267
M	1	Plug, Silicone	05-01429
N	2	Ties, Nylon Cable Push Mount	03-50492

Installation will require the following tools:

Panel clip remover, T-15 & T-20 Torx driver, 8mm nut driver, small flat-head screwdriver, 10mm & 11mm deep socket and driver, 20mm wrench or adjustable wrench.

Emissions Disclaimer: This product is not currently CARB exempt and is not available for purchase in California or for use on any vehicle registered with the California Department of Motor Vehicles.

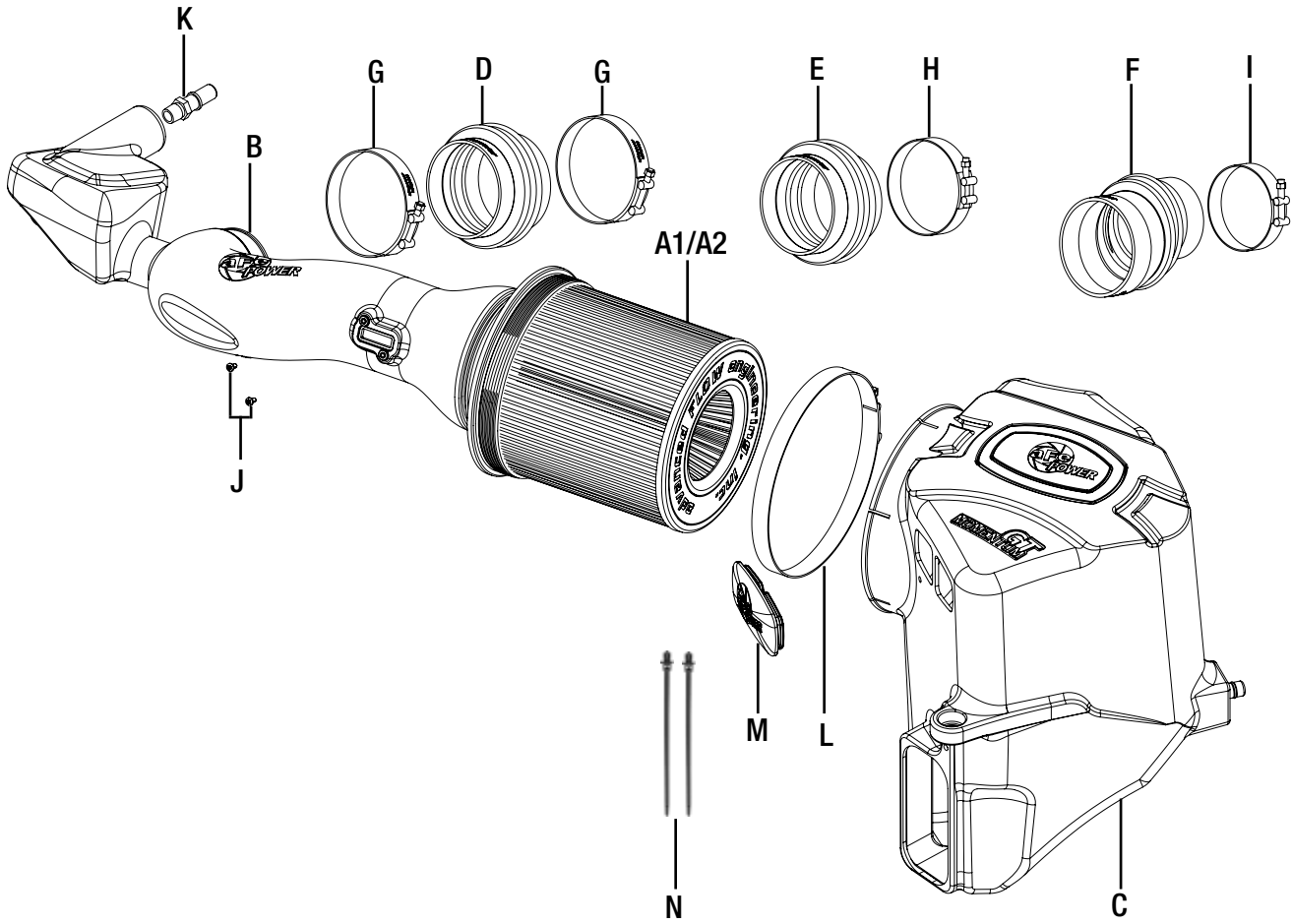

**Figure A****Refer to Figure A for Steps 1-3**

Step 1: Disconnect the MAF sensor ①.

Step 2: Disconnect the crankcase breather hose ② by pushing in the clip and pulling it out.

Step 3: Using an 8mm nut driver, loosen the hose clamps at the housing ③ and the throttle body ④.



Refer to Figure B for Step 5

Step 4: Remove the air cleaner outlet duct (5) by rotating it counterclockwise and snapping it out of the eyelet.

**Refer to Figure C for Step 5**

Step 5: Using a small flat-head screwdriver, release the locking tab at the wiring harness connector (6) and unsnap the two (x2) harness ties (7) then move the harness out of the way.



Refer to Figure D for Steps 6-7

Step 6: Using a T-15 Torx driver, remove the two screws (8) securing the hood latch and then slide it out to remove. Set the screws aside.

Step 7: Using a panel clip remover, remove all ten (x10) panel clips (9) holding the sight shield. Remove the shield and set it aside with the clips.



Refer to Figure E for Steps 8-10

Step 8: Using the clip remover, remove the clip (10) that's holding the air scoop and set aside.

Step 9: Pull the air scoop out of the way from the stock housing.

Step 10: Using a 10mm deep socket and driver, remove the nut (11) that secures the housing to the vehicle.



Figure F

Refer to Figure F for Step 11

Step 11: Remove the stock housing by pulling up out of the securing stud and towards the front of the vehicle, two pins with grommets will have to come out of the holding bracket and a clear path is needed so that the air scoop is not in the way of the housing. Then pull up on the housing to remove it from the vehicle.



Figure G

Refer to Figure G for Steps 12-13

Step 12: Remove the 2 grommets (12) from the stock housing pins and install them onto the aFe POWER housing.

Step 13: Remove the front metal insert and grommet (13) from the factory airbox and install them into the aFe POWER housing.



Figure H

Refer to Figure H for Steps 14-15

Step 14: Using a T-20 Torx driver, remove the MAF sensor (14) from the stock housing and install it on the aFe POWER intake tube using the supplied M4 screws.

Step 15: Using a 20mm wrench or adjustable wrench, install the supplied aluminum vent fitting (15) into the aFe POWER intake tube.

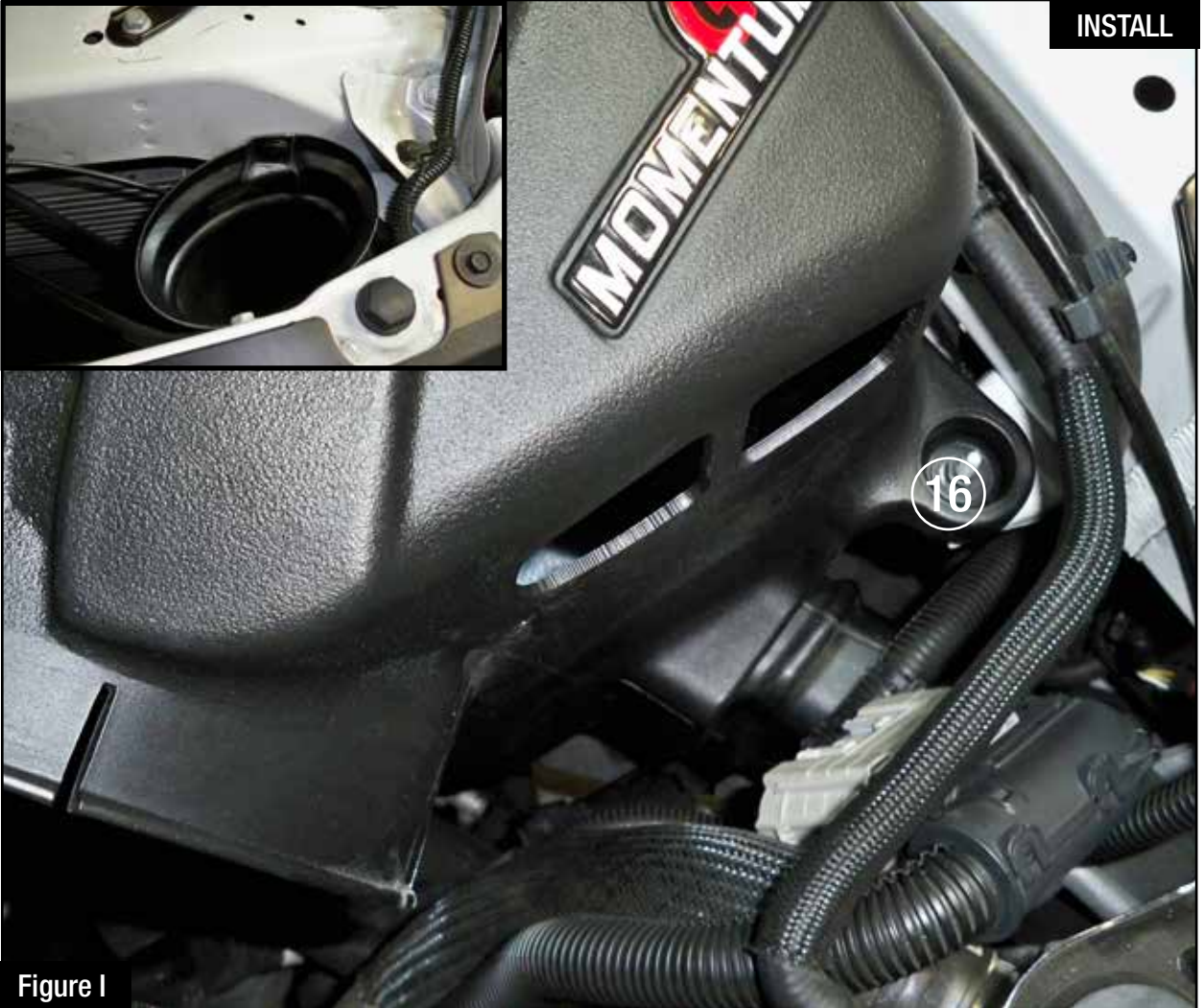

Figure I

Refer to Figure I for Steps 16-17

Step 16: Install the aFe POWER housing into the vehicle. Make sure the two (x2) pin grommets are secure inside the bracket and reinstall and tighten the nut ⑩ removed in Step 10.

Step 17: Slide the air scoop inside the front opening of the aFe POWER housing. Align the air scoop and reinstall the clip removed in Step 8.

INSTALL



Figure J

Refer to Figure J for Steps 18-19

Step 18: Install the sight shield with all ten (x10) clips removed in Step 7.

Step 19: Install the hood latch with the two (x2) screws removed in Step 6 and tighten them.

**Figure K****Refer to Figure K for Steps 20-22**

Step 20: Slide the large T-Bolt clamp (17) over the air filter opening on the housing.

Step 21: Slide the aFe POWER filter with clamp into the housing. Do not tighten the clamps.

Step 22: Use the provided plug (18) to close the additional air inlet if you want to completely seal the airbox. Best performance gain is obtained by having more air flow (no plug).



Figure L

Refer to Figure L for Step 23

Step 23: Depending on the engine, place the supplied corresponding aFe POWER coupling (19) and clamp (20) over the throttle body:

- V8-6.2L coupling 05-01509 & clamp TB412SS
- V8-5.3L coupling 05-01508 & clamp TB387SS
- V6-4.3L coupling 05-01510 & clamp TB337SS

**Figure M****Refer to Figure M for Steps 24-26**

Step 24: Place a TB412SS clamp (21) on the installed coupling.

Step 25: Install the aFe POWER intake tube into the vehicle. Slide the tube into the throttle body coupling first, then into the air filter.

Step 26: Align the tube and clamps correctly, then using a 11mm deep socket and driver tighten all the clamps.

**Figure N****Refer to Figure N for Steps 27-30**

Step 27: Reconnect the crankcase breather hose (22).

Step 28: Reconnect the MAF sensor (23).

Step 29: Use the supplied captive tie (24) to secure the wiring harness to the aFe POWER housing and snap the tie in the upper provided hole. Snap the factory tie on the harness into the hole by the air scoop.

Step 30: Check all the components are tight and secure. Your installation is now complete. Thank you for choosing aFe POWER!