

GT
MOMENTUM™

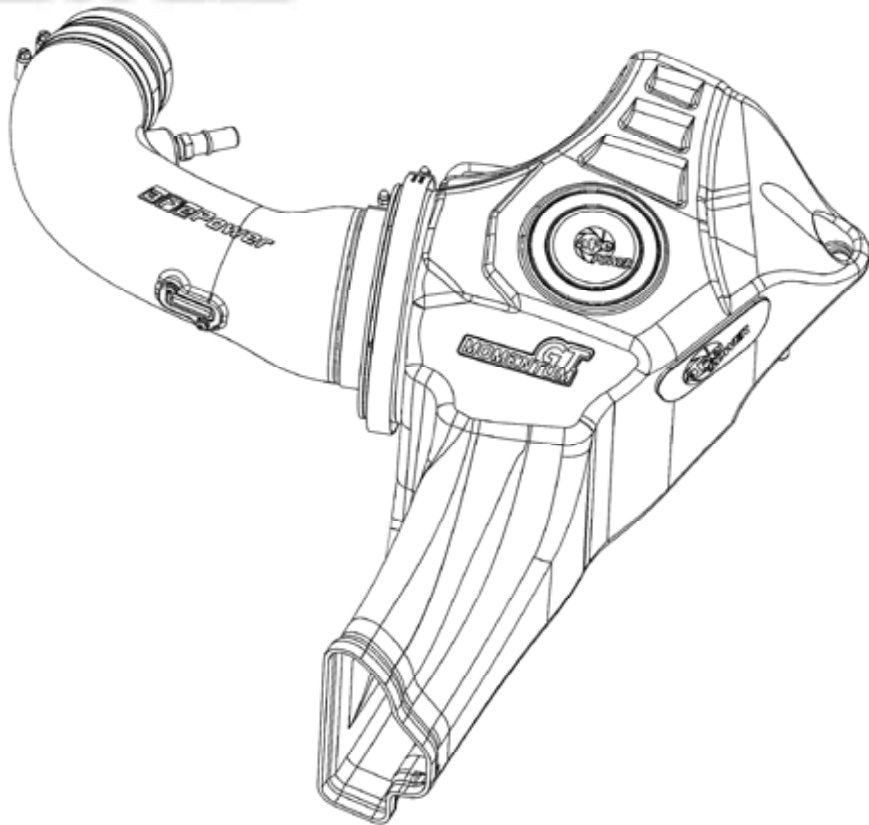

advanced FLOW engineering Momentum GT Cold Air Intake System

Instruction Manual P/N: 50-70033D / 50-70033R

Make: **Ford** Model: **Mustang GT** Year: **2018-2019** Engine: **V8-5.0L**



- Please read the entire instruction manual before proceeding.
- Ensure all components listed are present.
- If you are missing any of the components.
- Ensure you have all necessary tools before proceeding.
- Do not attempt to work on your vehicle when the engine is hot.



Retain factory parts for future use.

Label	Qty.	Description	Part Number
A1	1	Air Filter (Pro 5R)	24-91062
A2	1	Air Filter (Pro DRY S)	21-91062
B	1	Tube	05-5070033B1
C	1	Housing	05-5070033B2
D	1	Plug, Air Box	05-00937
E	1	Coupling, Silicone Reducer	05-01358
F	1	Clamp, #056	03-50009
G	1	Clamp, T-bolt (7.31" - 7.62")	03-50352
H	1	Fitting, Vent (Small)	05-01338
I	1	Fitting, Vent (Large)	05-01339
J	1	Cap, Vinyl	03-50623
K	2	Screw, Torx: M4	03-50490
L	1	Clamp, #060	03-50002

Installation will require the following tools:

8mm/7mm nut driver, 10mm/11MM deep socket & driver, pliers, T20 Torx bit, panel removal tool, flathead screw driver and adjustable wrench.

Note: Legal in California for use on race vehicles only. The use of this device on vehicles used on public streets or highways is strictly prohibited in California and others states that have adopted California emission regulations.

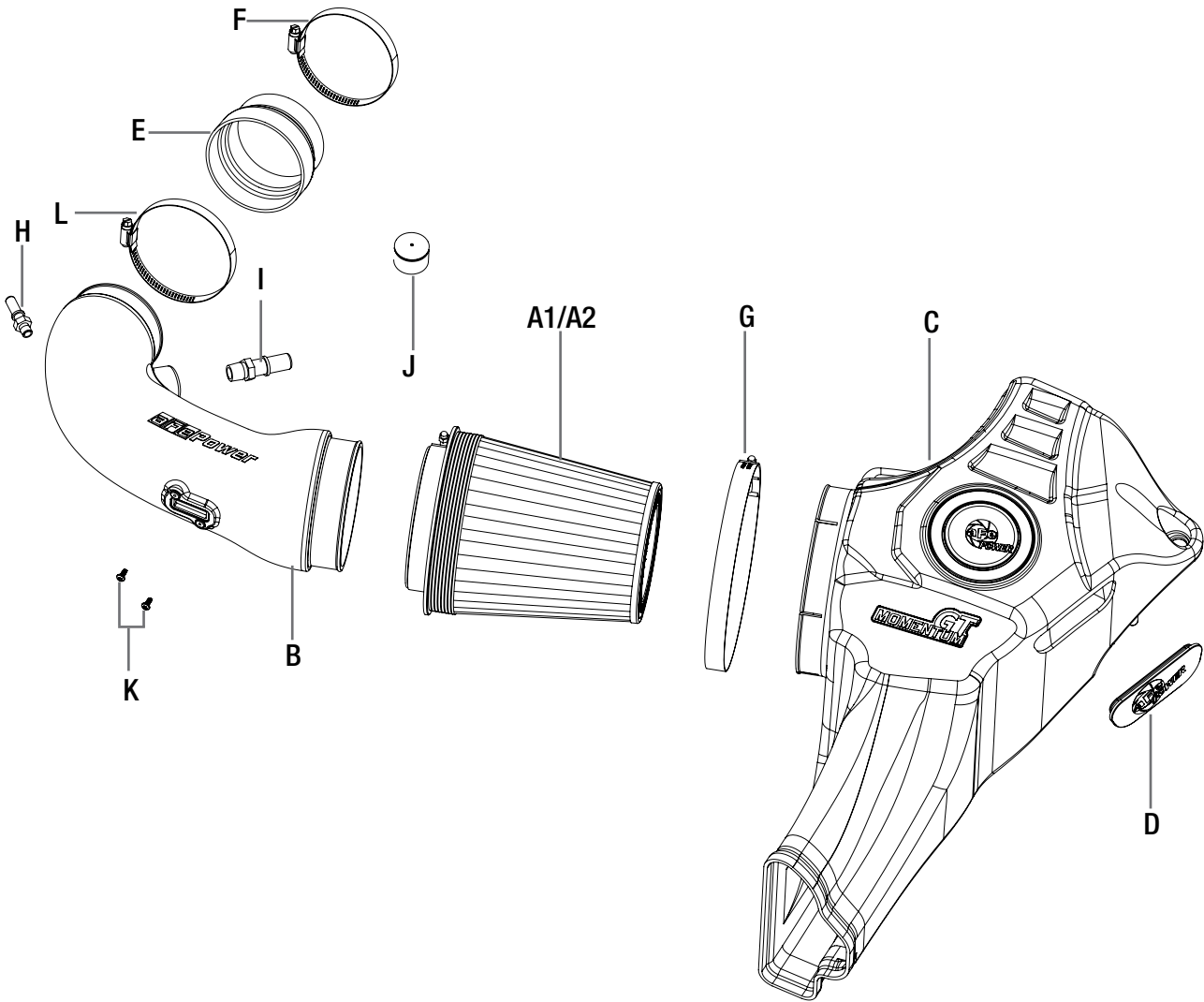



Figure A
Refer to Figure A for Steps 1-4

Step 1: Remove the engine cover by removing the bolt covers ① and removing the 10mm nuts.

Step 2: Loosen the two (2) clamps (7mm nut driver) on the intake tube. ②

Step 3: Disconnect the two (2) fittings on the intake tube. ③

Step 4: Slide the spring clamp ④ (pliers) up and disconnect the 1" rubber hose from the intake tube.

Note: Performance package models will require removal upper strut tower bar in order to remove engine cover.

**Figure B****Refer to Figure B for Steps 5-8**

Step 5: Remove the bolt (10mm socket) that is securing the housing to the fender. (5)

Step 6: Disconnect the Mass Air Flow (MAF) sensor (6) and unclip the rest of the wire harness from the side of the factory air box.

Step 7: Remove the sound chamber (7) from the air box by removing the metal clip (8) with a small flat head screwdriver. Then pull up on the small box.

Step 8: Slip the intake tube out off the throttle body and pull up on the back of the air box to remove the factory intake system.

**Figure C****Refer to Figure C for Steps 9-10**

Step 9: Relocate the terminal connector, located on the fender well, to the hole nearest the front of the vehicle as shown. ⑨

Step 10: Disconnect the push clips located further down on the wire harness. This will allow slack to reconnect the MAF sensor later. ⑩



Figure D

Refer to Figure D for Steps 11-13

Step 11: Pull out the metal sleeve and rubber grommet ①① from the factory air box.

Step 12: Remove the rubber guide bushing ①② from the factory air box.

Step 13: Transfer the grommet, sleeve, and guide bushing to the new aFe POWER housing.



Figure E

Refer to Figure E for Steps 14-15

Step 14: Remove the MAF sensor (13) from the factory air box using a T20 torx bit.

Step 15: Install the MAF sensor into the new aFe POWER intake tube using the new M4x10mm torx screws (14).



Figure F

Refer to Figure F for Step 16

Step 16: Pre-install the two aluminum fittings (15) with an adjustable wrench into their respective locations on the intake tube.

NOTE: The supplied two (2) aluminum fittings are NPT threads and will not bottom out in the tube. DO NOT OVER TIGHTEN!

**Figure G****Refer to Figure G for Steps 17-19**

Step 17: Install the aFe POWER housing (16) into the vehicle. Install the T-bolt clamp (17) along with the air filter (18). Do not tighten clamps at this time.

Step 18: Install the reducer coupler (19) and the smaller worm-gear clamp (20) onto the throttle body and tighten clamp.

Step 19: Use the factory bolt (10mm socket) to secure the new aFe POWER housing in place.

NOTE: Make sure the MAF sensor harness is pulled back out of the way before installing the housing.



Figure H

Refer to Figure H for Steps 20-22

Step 20: Place the large worm-gear clamp (21) on the other end of the silicone coupler, but do not tighten.

Step 21: Install the aFe POWER intake tube (22) into the vehicle by slipping into the air filter then by rotating it into the coupler.

Step 22: Re-connect the harness to the MAF sensor (23) and tighten all clamps.



Figure I

Refer to Figure I for Steps 23-25

Step 23: Connect all the fittings (24) back to the respective locations.

Step 24: Re-install the engine cover (25) with the two (x2) 10mm nuts removed from Step 1. Then snap covers into place.

Step 25: Block off the sound port (26) with the supplied cap.

INSTALL



Figure J

Refer to Figure J for Steps 26-27

Step 26: Ensure all clamps are tightened and fully secured.

Step 27: Your installation is now complete. Thank you for choosing aFe POWER!

NOTE: Check all bolts, clamps, and connectors after 100-200 miles.