

XP
MOMENTUM

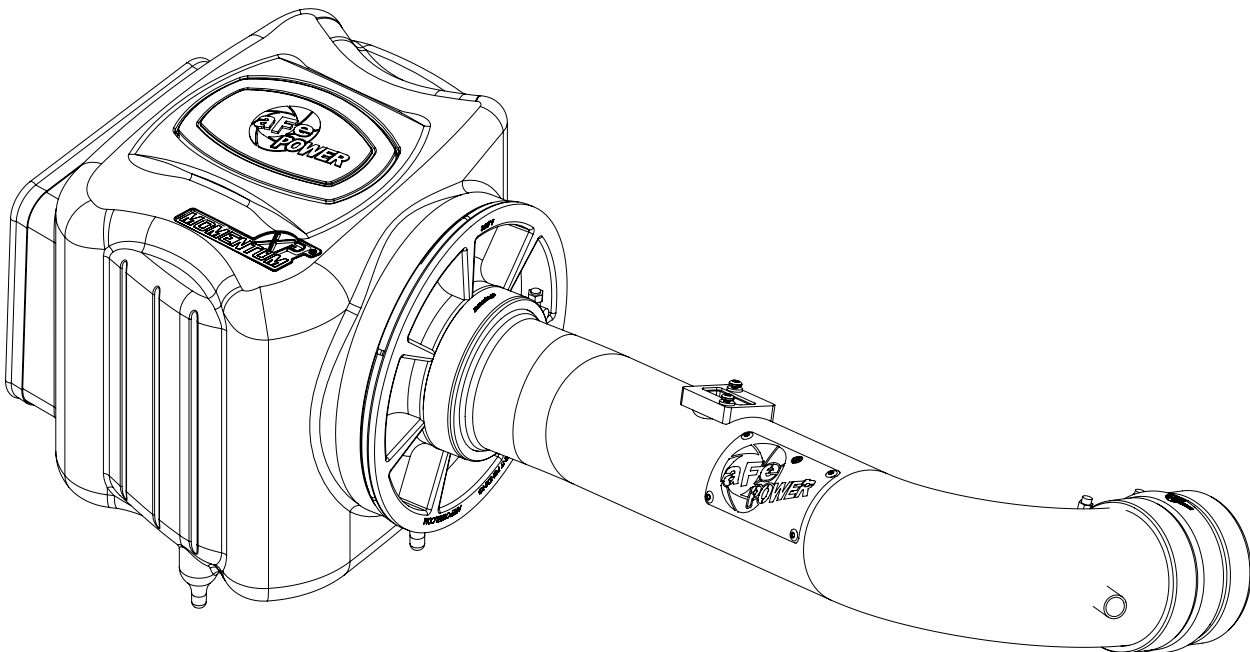

advanced FLOW engineering Momentum XP Air Intake

Instruction Manual P/N: 50-30028D / 50-30028R / 50-30028DH / 50-30028RH

Make: GM	Model: Silverado/Sierra	Year: 2014-2018	Engine: V8-5.3L / 6.2L
Make: GM	Model: Tahoe/Yukon	Year: 2015-2018	Engine: V8-5.3L / 6.2L
Make: GM	Model: Suburban/Yukon XL	Year: 2015-2018	Engine: V8-5.3L / 6.2L
Make: Cadillac	Model: Escalade/ESV	Year: 2015-2018	Engine: V8-6.2L

NOTE: Includes Denali models.



- Please read the entire instruction manual before proceeding.
- Ensure all components listed are present.
- Ensure you have all necessary tools before proceeding.
- Do not attempt to work on your vehicle when the engine is hot.
- Disconnect the negative battery terminal before proceeding.
- Retain factory parts for future use.

Label	Qty.	Description	Part Number
A1	1	Pro DRY S Air Filter	21-91079
A2	1	Pro 5R Air Filter	24-91079
B	1	Housing	05-5030028B2
C1	1	Tube (Black)	05-5030028B1
C2	1	Tube (Brushed)	05-5030028H1
D	1	Coupling, Silicone Hump	05-01264
E	2	Clamp, T-bolt (3-9/16" - 3-7/8")	03-50498
F	1	Clamp, T-bolt (8-5/16")	03-50267
G	1	Hose, Silicone Breather: 1/2"ID (13" in.)	05-01396
H	1	Hose, Silicone Breather: 1/2"ID (16" in.)	05-01396
I	1	Seal, Trim: 7/16" (28" in.)	05-00072
J	2	Screws, Torx: M4	03-50491
K	1	Plug	05-00937
L	1	Coupling, Silicone Reducer	05-01203
M	1	Clamp, T-bolt (3-13/16" - 4-1/8")	03-50265

Tools required for installation:

8mm nut driver, 11mm nut driver, T15 & T20 torx bit or driver and flat screw driver.

aFe are proud to offer a high quality product at the industries most competitive pricing!

Note: Legal in California for use on race vehicles only. The use of this device on vehicles used on public streets or highways is strictly prohibited in California and others states that have adopted California emission regulations.

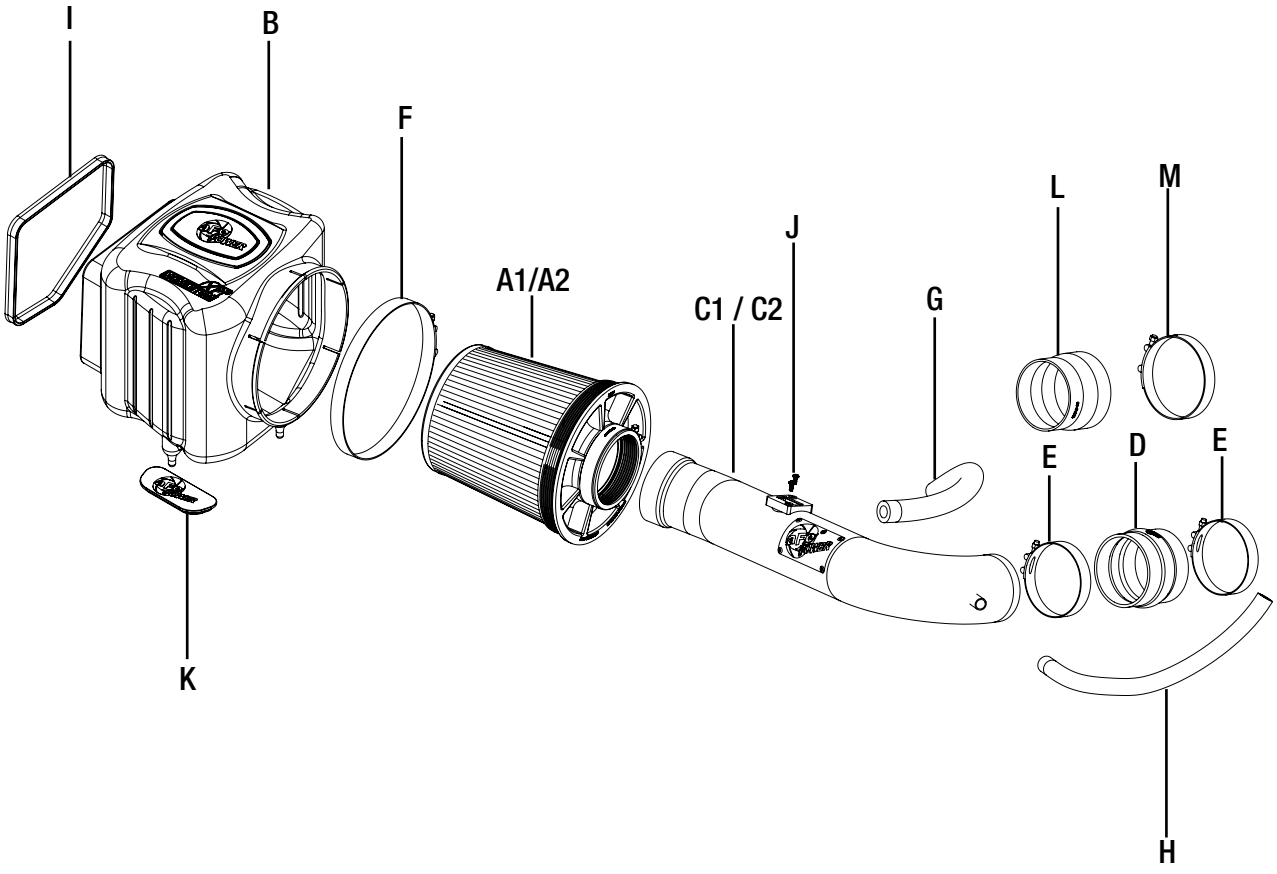

**Figure A****Refer to Figure A for Steps 1-3**

Step 1: Disconnect the MAF sensor plug ①.

Step 2: Using a 8mm nut driver, loosen the clamp at the airbox ②.

Step 3: Using a 8mm nut driver, loosen the clamp at the throttle body ③.

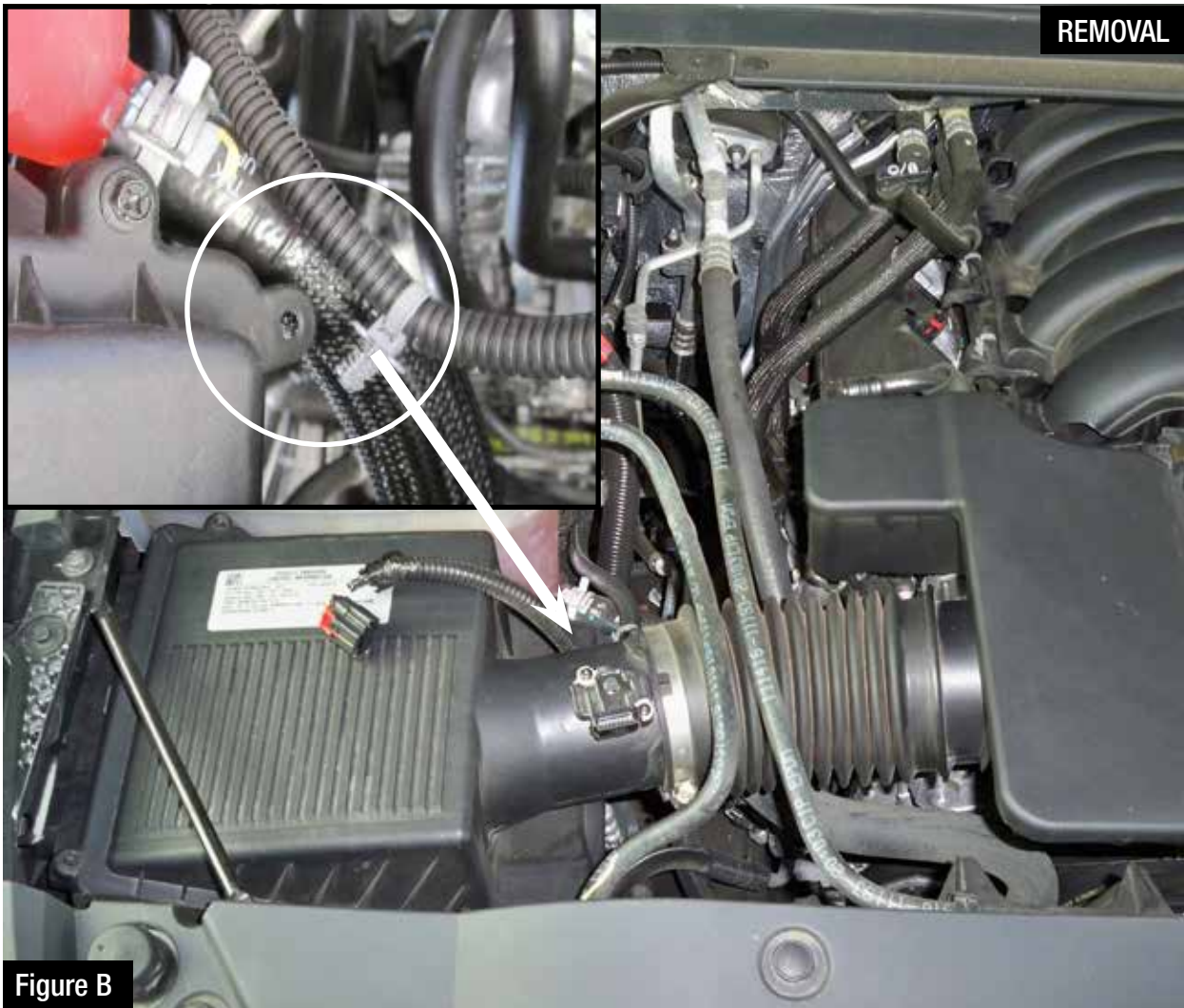

Figure B

Refer to Figure B for Step 4

Step 4: Disconnect the MAF sensor harness clip from the OE airbox.



Refer to Figure C for Steps 5-6

Step 5: Disconnect the OE crankcase breathers from the valve covers (as shown) on both sides of the engine.

Step 6: Carefully remove the entire intake tube plenum with the crankcase breather plugs attached.



Figure D

Refer to Figure D for Step 7

Step 7: Remove the factory airbox out of the vehicle (4).



Figure E

Refer to Figure E for Step 8

Step 8: Use the supplied plug (5) to close the auxiliary air inlet if you want to completely seal the airbox. Install the supplied large T-bolt clamp (6) on the aFe airbox. Slide the air filter with clamp into the aFe airbox. Do not tighten the clamps at this time.



Refer to Figure F for Steps 9-10

Step 9: Install the trim seal on the opening of the aFe airbox (7).

Step 10: Remove the retaining plug (8) from the bottom of the factory airbox and transfer it to the aFe airbox.



Figure G

Refer to Figure G for Step 11

Step 11: Install the aFe airbox assembly into the vehicle. Firmly push it into the factory mounting grommets.



Figure H

Refer to Figure H for Steps 12-13

Step 12: Remove the mass air flow sensor from the factory airbox using a T15 Torx.

Step 13: Using a T20 torx, install the mass air flow sensor into the aFe intake tube using the supplied M4 screws and factory seal.

**Figure I****Refer to Figure I for Steps 14-16**

- Step 14: For V8-5.3L, install the supplied hump coupling and the 2 smaller clamps on the throttle body.
For V8-6.2L, install the supplied reducer coupling and 1 small and 1 larger clamps on the throttle body. Do not tighten clamps at this time.
- Step 15: Install the intake tube (9) into the vehicle. Slide the tube into the filter, then into the coupling on the throttle body.
- Step 16: Align the tube correctly then tighten all clamps .

**Figure J****Refer to Figure J for Steps 17-19**

Step 17: Install the two supplied crankcase breather hoses (10) between the valve cover and the aFe tube on both passenger and driver side. (Make sure hoses are secure over the bead).

Step 18: Reconnect the mass air flow sensor harness (11).

Step 19: Make sure all clamps and connections are secured. Your installation is now complete!



Pro DRY S Air Filter



P/N: 21-91079

Pro 5R Air Filter



P/N: 24-91079

Pre-Filter



P/N: 28-10273

Pro DRY S Restore Kit



P/N: 90-59999

Blue Squeeze Restore Kit



P/N: 90-50501

Sprint Booster V3



P/N: 77-14003

SCORCHER PRO Tune



P/N: 77-34004

Twisted Steel Shorty Headers



P/N: 48-44003

Oil Filter



P/N: 44-LF025

Throttle Body Spacer



P/N: 46-34008 (For 5.3L)

Transmission Pan



P/N: 46-70242 (Black)
46-70240 (RAW)

Dual Exit Exhaust System



P/N: 49-44071-B (Blk. Tips)
49-44071-P (Pol. Tips)

Shop for other performance air intake systems on our website.