



FORD POWER STROKE

2003 - 2007 V8-6.0L (td)

P/N
49-43003
49-43004
49-43005
49-13003
49-13004
49-13005

DIESEL EXHAUST



Features:

- › High performance
- › 4" mandrel-bent
- › 409 SS or aluminized
- › Lowers EGT's
- › OE style clamps and hangers

Benefits:

- › + 29% flow increase
- › + 16 lbs x ft torque
- › + 5 H.P.





Installation Instructions for: FORD POWER STROKE 2003-2007 V8-6.0L (td)



49-43003 (409SS) Cat-Back

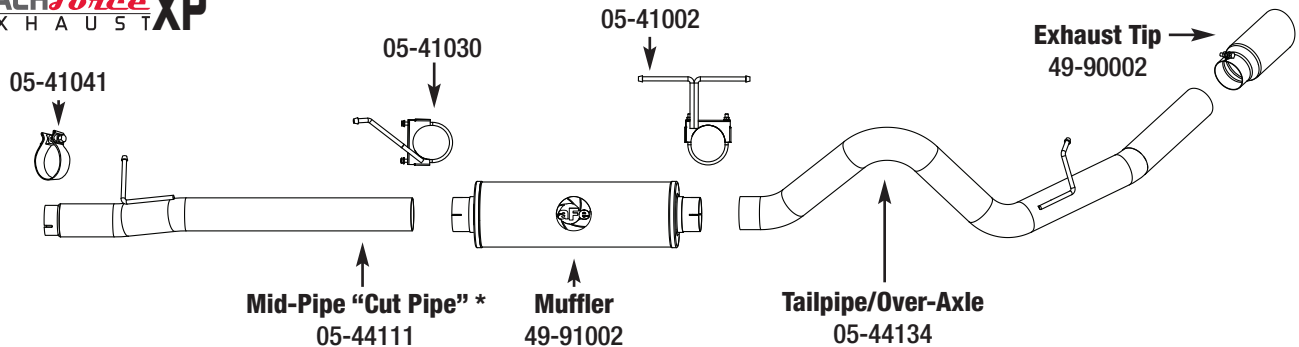

1: (Read Instructions prior to installation) Remove your stock exhaust up to the catalytic converter, from the rear of your truck working your way forward. Take caution not to damage the factory isolation mounts. *It is recommended to not fully tighten the clamps until the entire system has been installed.*

2: For faster installation spread the pieces of the exhaust along side of your vehicle according to the diagram shown.

3: Install the tailpipe/over-axle. Use the factory isolation mounts.

4: Now with the tailpipe/over-axle is in place fasten the muffler in position using the two clamps indicated.

5: Next install the mid-pipe, if you have a crew-cab long bed you will not need to cut this pipe. All other cabs this pipe will need to be cut to length.

6: Once you have fit the mid-pipe, the factory isolation mounts should be angled forward. Now make sure to tighten all clamps from front to rear. Install the exhaust tip and tighten. Your installation is now complete. It is recommended to re-tighten all parts after 50-100 miles.

LARGE BORE HD Exhaust

49-13003 (Aluminized) Cat-Back

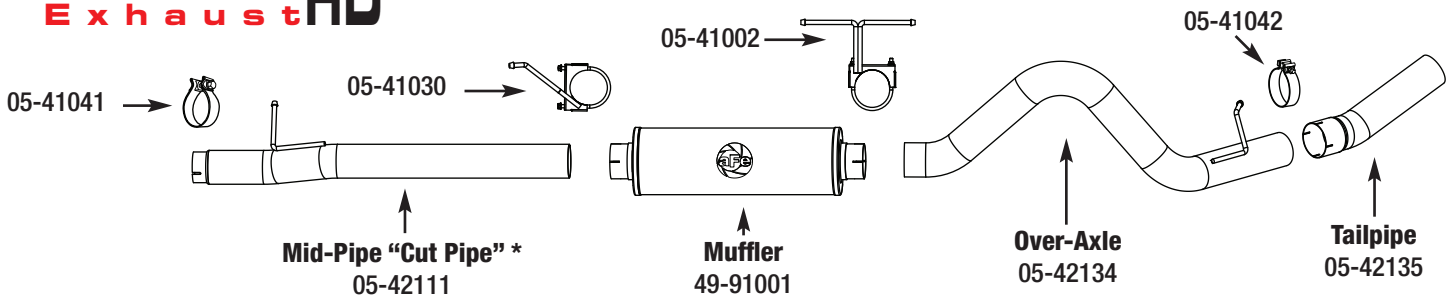

1 & 2: See above

3: Install the over-axle. Use the factory isolation mounts.

4 & 5: See above

6: Once you have fit the mid-pipe, the factory isolation mounts should be angled forward. Now make sure to tighten all clamps from front to rear. Install the tailpipe and tighten. Your installation is now complete. It is recommended to re-tighten all parts after 50-100 miles.

NOTE:

* Mid-Pipe Tube will not need cutting if being installed on: **Crew-Cab LB**
Other models: Cut tube to length.

Important: Cut tube at non-reduced muffler end.

• aFe recommends that the tailpipe be at least 1/2"-1" away from any body panels to avoid heat related body damage. **Tighten and secure.**

Caution: Allow time for your vehicle to cool down prior to installation. When working on or under your vehicle proceed with caution. Exhaust systems reach high temperatures and may cause serious burns. Wear protective safety equipment; eye goggles and gloves to ensure a safe installation. **aFe recommends professional installation on our products.**



Installation Instructions for: FORD POWER STROKE 2003-2007 V8-6.0L (td)

49-43005 (409SS) Turbo-Back

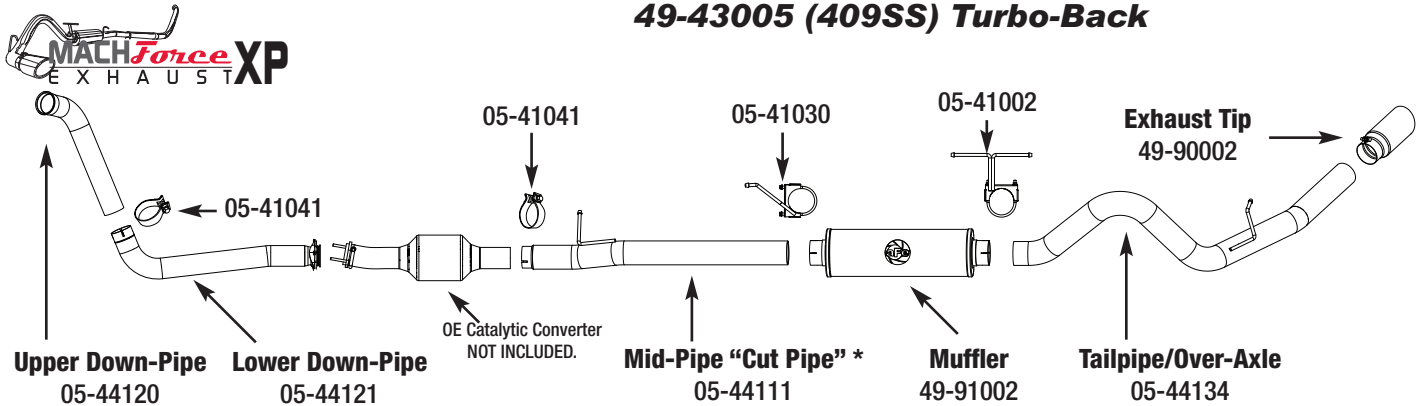

1: (Read Instructions prior to installation) Remove your stock exhaust from the rear of your truck working your way forward. Take caution not to damage the factory isolation mounts. If you want to remove the OE downpipe in one piece or without cutting, you must remove the transmission cross member and disconnect the dip-stick tube & sway bar end links. *It is recommended to not fully tighten the clamps until the entire system has been installed.*

2: For faster installation spread the pieces of the exhaust along side of your vehicle according to the diagram shown.

3: Install the upper downpipe first, then install the lower downpipe. Connect the lower downpipe to the OE catalytic converter. Fasten the clamp onto the slip joint.

4: Install the tailpipe/over-axle. Use the factory isolation mounts.

5: Now with the tailpipe/over-axle in place, fasten the muffler in position using the two clamps indicated.

6: Next install the mid-pipe. If you have a crew-cab long bed you will not need to cut this pipe. For all other cabs, this pipe will need to be cut to length.

7: Once you have fit the mid-pipe, the factory isolation mounts should be angled forward. Now make sure to tighten all clamps from front to rear. Install the exhaust tip and tighten. Your installation is now complete. *It is recommended to re-tighten all parts after 50-100 miles.*

LARGE BORE Exhaust HD

49-13005 (Aluminized) Turbo-Back

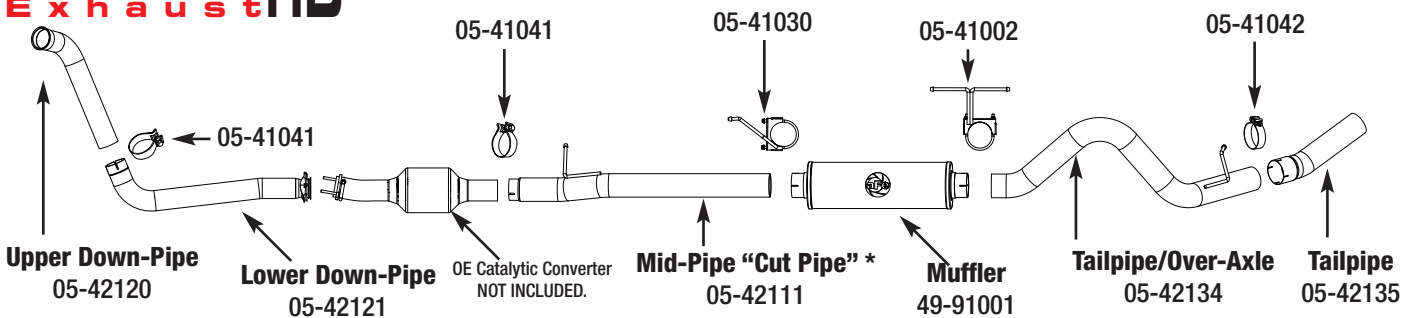

1, 2 & 3: See above

4: Install the over-axle. Use the factory isolation mounts.

5 & 6: See above

7: Once you have fit the mid-pipe, the factory isolation mounts should be angled forward. Now make sure to tighten all clamps from front to rear. Install the tailpipe and tighten. Your installation is now complete. *It is recommended to re-tighten all parts after 50-100 miles.*

NOTE:

* Mid-Pipe Tube will not need cutting if being installed on: **Crew-Cab LB**

Other models: Cut tube to length.

Important: Cut tube at non-reduced muffler end.

• aFe recommends that the tailpipe be at least **1/2"-1"** away from any body panels to avoid heat related body damage. **Tighten and secure.**

Caution: Allow time for your vehicle to cool down prior to installation. When working on or under your vehicle proceed with caution. Exhaust systems reach high temperatures and may cause serious burns. Wear protective safety equipment; eye goggles and gloves to ensure a safe installation. **aFe recommends professional installation on our products.**



Installation Instructions for: FORD POWER STROKE 2003-2007 V8-6.0L (td)

49-43004 (409SS) Turbo-Back Off-road

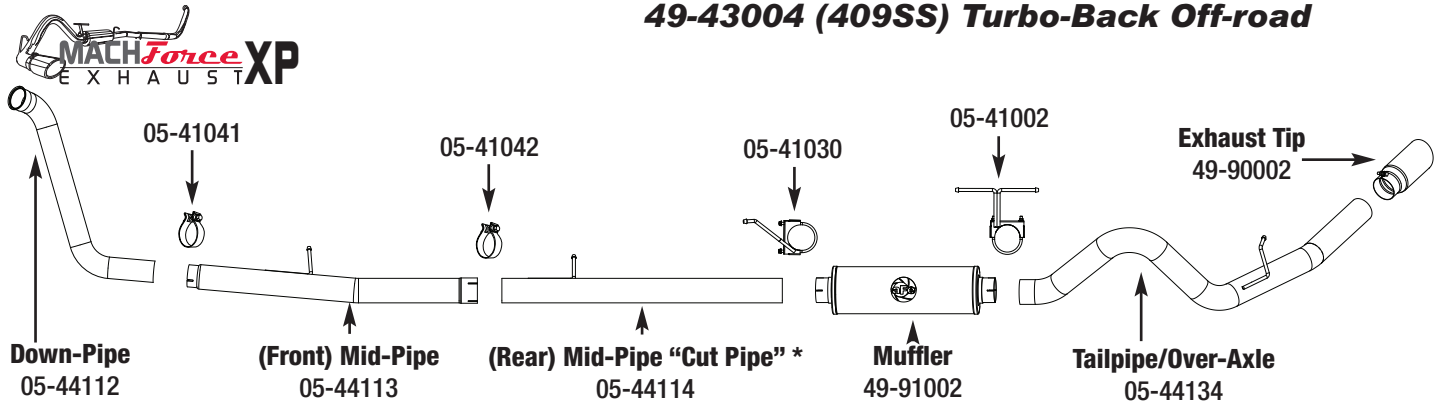

1: (Read Instructions prior to installation) Remove your stock exhaust from the rear of your truck working your way forward. Take caution not to damage the factory isolation mounts. If you want to remove the OE downpipe in one piece or without cutting, you must remove the transmission cross member and disconnect the dip-stick tube & sway bar end links. *It is recommended to not fully tighten the clamps until the entire system has been installed.*

2: For faster installation spread the pieces of the exhaust along side of your vehicle according to the diagram shown.

3: Install the down-pipe first, then install the front mid-pipe. Fasten the clamp onto the slip joint.

4: Install the tailpipe/over-axle. Use the factory isolation mounts.

5: Now with the tailpipe/over-axle in place, fasten the muffler in position using the two clamps indicated.

6: Next install the rear mid-pipe. If you have a crew-cab long bed you will not need to cut this pipe. For all other cabs, this pipe will need to be cut to length.

7: Once you have fit the rear mid-pipe, the rubber isolators should be angled forward. Now make sure to tighten all clamps from front to rear. Install the exhaust tip and tighten. Your installation is now complete. It is recommended to re-tighten all parts after 50-100 miles.

LARGE BORE HD Exhaust

49-13004 (Aluminized) Turbo-Back Off-road

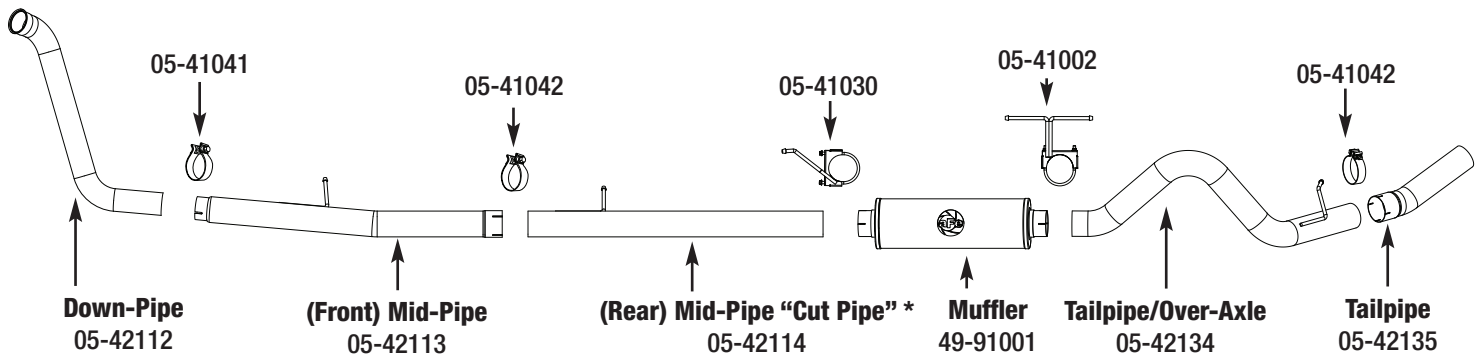

1, 2 & 3: See above

4: Install the over-axle. Use the factory isolation mounts when possible.

5 & 6: See above

7: Once you have fit the rear mid-pipe, the rubber isolators should be angled forward. Now make sure to tighten all clamps from front to rear. Install the tailpipe and tighten. Your installation is now complete. It is recommended to re-tighten all parts after 50-100 miles.

NOTE:

* (Rear) Mid-Pipe Tube will not need cutting if being installed on: **Crew-Cab LB**
Other models: Cut tube to length.

Important: Cut tube at end farthest from hanger.

• aFe recommends that the tailpipe be at least 1/2"-1" away from any body panels to avoid heat related body damage. **Tighten and secure.**

Caution: Allow time for your vehicle to cool down prior to installation. When working on or under your vehicle proceed with caution. Exhaust systems reach high temperatures and may cause serious burns. Wear protective safety equipment; eye goggles and gloves to ensure a safe installation. **aFe recommends professional installation on our products.**