

WMMTC

AFE CONTROL



Description: PFADT Series [Lowering Kit](#) Corvette (C6/C7) 05-16
Part Number: 410-401001-A

Tools Needed:

- 3/8" drive ratchet
- 3/8" extensions
- 3/8" drive torque wrench
- Sharpie marker
- 10mm deep socket
- 13mm socket
- 13mm deep socket
- 15mm socket
- 18mm deep socket
- 21mm deep socket
- lug nut socket (stock 19mm)
- 8 mm combination wrench
- 10mm combination wrench
- 13mm combination wrench
- 18mm combination wrench
- 21mm combination wrench
- M14 x 2.0 Tap
- 1/2" drive breaker bar
- 1/2" drive torque wrench
- floor jack
- jack stands

This procedure is best performed on a vehicle lift, however it is possible to install this lowering kit using a floor jack and jack stands.

Note: Your Corvette will require a full alignment after the installation of this lowering kit. **Any** ride height change on a Corvette will affect the alignment settings requiring a re-alignment.

Front

Position your Corvette on a level surface and make reference measurements of your ride height prior to starting installation. You can use either fender arches, or frame to ground – whichever is convenient. You will use these when fine tuning your ride height after installation.

Note the Measurements Here:

Before : LF _____ RF _____ LR _____ RR _____

After : LF _____ RF _____ LR _____ RR _____

Using proper jacking points, lift and support the front of the car on jack stands.

Remove both front wheels.

Disconnect the front Swaybar endlink from both control arms (18mm nut). Hold the Stud from turning with an 8mm box end wrench

Support the lower control arm with a jack during the removal of the lower shock bolts to prevent bolt damage.

Remove the bolts holding the lower front shock mounts to the control arms (13mm nuts)

Lower the jack releasing tension on the control arm. Repeat these steps on the other side of the vehicle.

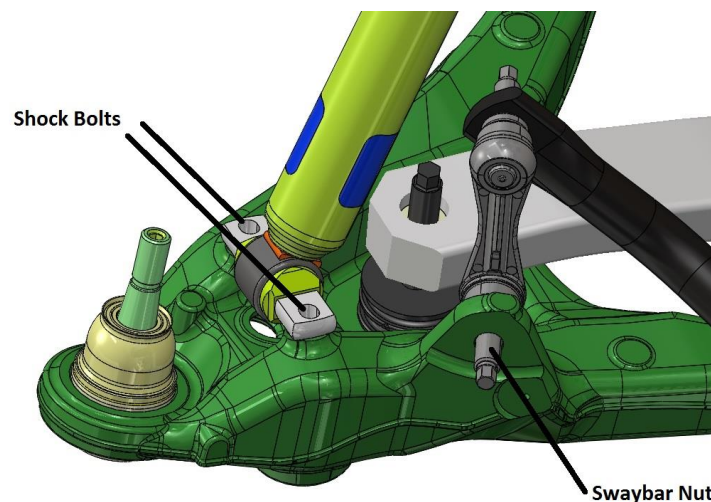

Using the Sharpie marker mark the rotation of each of the camber adjustment eccentrics that mount the lower control arms to the subframe. This will be used to get a baseline adjustment upon re-assembly.

Measure the height of the stock adjuster above the spring for use in setting a reference adjuster height for the new adjusters. See Diagram below.

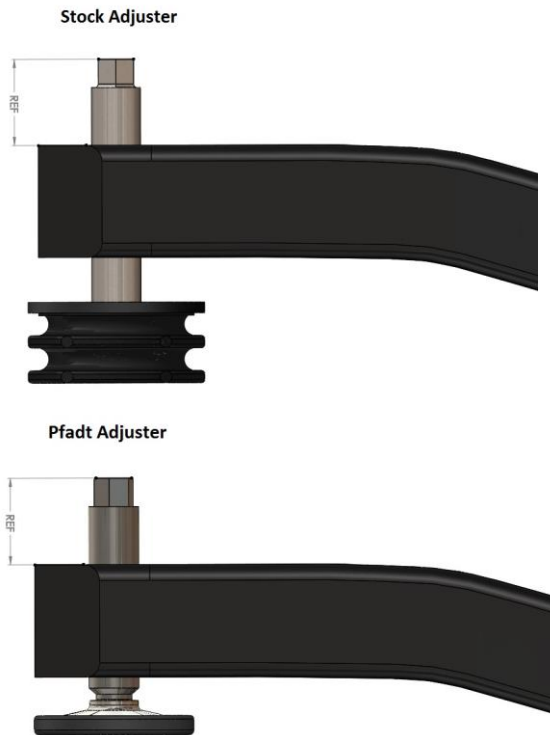

Loosen each of the lower control arm bolts enough to allow the eccentrics to slip out of their grooves. This allows the maximum movement of the lower control arm.

!! CAUTION: Keep fingers clear of pinch areas while compressing the spring !!

Using a jack, compress one side of the spring to create clearance between the adjuster foot and the lower control arm. You can jack the spring through the 'V' in the control arm. **Use caution to not nick or damage the fiberglass of the spring with the jack head.**

Thread the stock adjuster screw down through the spring until it will come out of the spring. This will be a tight fit, but the adjuster will come out.

Note: Internal spring threads contain a thread locking compound. It is recommended to chase the threads with an M14 x 2.0 tap. This will ease the installation of the adjuster assembly.

Install a new lowering bolt from bottom of spring – all 4 are identical. Thread the bolt to your measured reference height from the previous step.

Release tension on the spring and repeat install of bolt on the other side.

Install control arm eccentrics back into their proper slots in the subframe and orient them to the marks you made previously.

Jack up on the lower control arm and install the lower shock mount bolts and torque to 21 lb-ft. Repeat on the other side.

Torque lower control arm eccentric bolts to 100 lb-ft, being careful to maintain the alignment of your marks.

Re-install the Swaybar endlinks and torque the nuts to 30 lb-ft.

Re-install wheels and lower the car.

Rear

Using proper jacking points, lift and support the rear of the car on jack stands.

Remove both rear wheels.

Disconnect the rear Swaybar endlink (if equipped) from both lower control arms (18mm nut).

Hold the Stud from turning with an 8mm box end wrench

Support the lower control arm with a jack during the removal of the lower shock bolt to prevent damage.

Remove the bolt holding the lower shock mount to the control arms – **Note** the nut is attached to the shock bracket

Lower the jack releasing tension on the control arm. Repeat these steps on the other side of the vehicle.

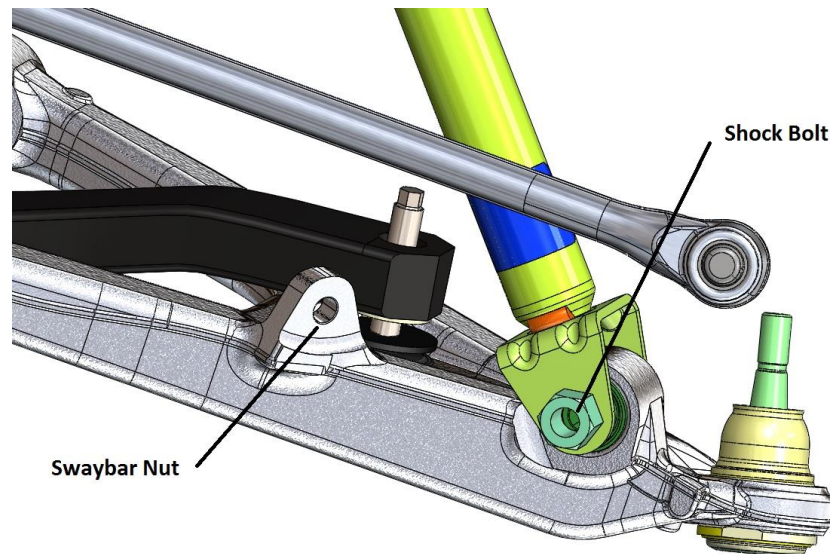

Using the Sharpie marker, mark the rotation of each of the camber adjustment eccentrics that mount the lower control arms to the subframe. These marks will be used to get a baseline adjustment upon re-assembly.

Measure the height of the stock adjuster above the spring for use in setting a reference adjuster height for the new adjusters. See Diagram in Front installation.

Loosen each of the lower control arm bolts enough to allow the eccentrics to slip out of their grooves. This allows the maximum movement of the lower control arm.

Using a jack, compress one side of the spring to create clearance between the adjuster foot and the lower control arm. You can jack the spring through the 'V' in the control arm. **Use caution to not nick or damage the fiberglass of the spring with the jack head.**

!! CAUTION: Keep fingers clear of pinch areas while compressing the spring !!

Thread the stock adjuster screw down through the spring until it will come out of the spring. This will be a tight fit, but the adjuster will come out.

Install new lowering bolt from bottom of spring. Thread the bolt to your measured reference height from the previous step. Refer to the diagram in the front bolt instructions.

Release tension on the spring and repeat install of bolt on the other side.

Install control arm eccentrics back into their proper slots in the subframe and orient them to the marks you made previously.

Jack up on the lower control arm and install the lower shock mount bolt and torque to 30 lb-ft. Repeat on the other side.

Torque lower control arm eccentric bolts to 100 lb-ft, being careful to maintain the alignment of your marks.

Re-install the Swaybar endlinks (if equipped) and torque the nuts to 30 lb-ft.

Re-install wheels and lower the car.

	Torque
Swaybar Endlink Nut	30 lb-ft
Front Lower Shock Mounting bolts/Nuts	21 lb-ft
Rear Lower Shock Mounting Bolt	30 lb-ft
Lower Control Arm Bolts	100 lb-ft

Ride Height/Alignment

Your Corvette will now require fine setting of the ride height. You will need to drive your car some miles to allow the new ride height to settle in before fine tuning and getting a final alignment.

Avoid any highway driving or high speeds while performing the settling of the car. It is recommended to drive the car at least 10 miles before setting/verifying ride height.

Compare your measurements – post test drive – to the ones from before the installation.

To raise the car, turn the adjuster screws clockwise (CW) with a 10mm wrench or socket. To lower the car turn the screws counterclockwise (CCW). It is recommended to lift the car prior to making height adjustments to reduce the load on the threads and make the adjusters turn easier.

Once the ride height is set to your satisfaction, take the vehicle to a qualified alignment shop for a proper 4 wheel alignment. There are stock alignment specifications available in the Owners Manual of your Corvette.

