

# INSTALLATION MANUAL

18119

## Level of Difficulty

Easy

Installation difficulty levels are based on time and effort involved and may vary depending on the installer level of expertise, condition of the vehicle and proper tools and equipment.

## Parts List

Qty	Description
2	Cross tubing
4	Bottom flange bracket
4	Locking bracket
4	Cover bracket
4	Cam lock handle, M10
4	Flat washer, M10
4	Button head cap screw, M12
4	Flat washer, M12
4	Lock washer, M12
4	3M tape strip, 60mm
4	3M tape strip, 70mm

## Tools Required

Allen wrench	--
--------------	----

## Torque Specifications

M12 bolt	40 ft-lbs.
Use above torque setting unless otherwise noted	

## Maintenance

Mild automotive detergent may be used to clean the product. Do not use dish detergent, abrasive cleaners, abrasive pads, wire brushes or other similar products that may damage the finish.

## Product Photo



## NOTICE

Before you begin installation, read all instructions thoroughly.

Proper tools will improve the quality of installation and reduce the time required.

Periodic inspection of your product should be performed to ensure all hardware and / or components remain secure.

When using the roof cargo gutter brackets do not exceed the max weight capacity of 150 lbs.

This includes the weight of the cargo plus the weight of all accessories used in carrying the cargo.

Do not exceed height of 18 inches from the top of the cross tubing.

For best and safe use of the CURT roof cargo brackets and accessories, the user must understand the precautions.

Do not over tighten the cam handle or it could cause cracking or breaking of the roof gutter (see page 3 for more details).

Make sure you understand and check local and state laws governing projection of objects beyond vehicle. Always be aware of the width and height of the cargo to ensure clearance in tunnels, bridges, branches and spaces that require clearance.

Never drive anywhere without fully securing the brackets and cargo.

Periodically check to make sure the brackets, basket and cargo are fully secured during travel.

Be sure with long cargo, such as kayaks or surfboards, that you have it fully secured on the front and rear bumper or tow hooks of the vehicle. Be sure to check vehicle manual for safe tie-down areas that will not cause damage.

Remove all roof cargo brackets, basket and all cargo before entering automated car washes.

For safest driving results be aware of posted speed limits, weather / road conditions and the load of the cargo.

Roof cargo brackets are not for off-road use, trailer use or towing of vehicles.

Roof cargo brackets are not recommended for carrying liquids or flammable materials.

Consult with your CURT dealer if you have any questions regarding the operations or limits of CURT products. Be sure to review and understand all warranties and instructions carefully.

Do not use roof cargo brackets for anything other than what they are designed for or exceed load capacity. Failure to do this will void all warranties of the product.

All warranty is void in the case of an accident or a collision.

To help prevent damage to the product or vehicle, refer to the specified torque specifications when securing hardware during the installation process.

### Step 1

Clean off the Jeep's hard top and place the cross tubing on the hard top.

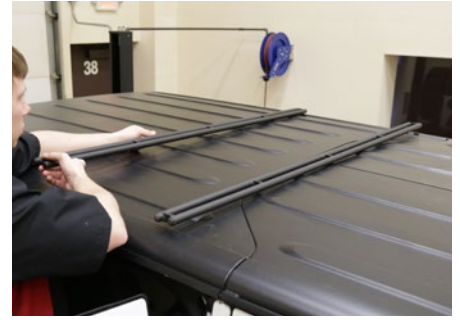

### Step 2

Locate one bottom flange bracket and one cover bracket. Slide the brackets together and apply one 60mm and one 70mm 3M tape strip. Attach to flanges.

**Note:** The brackets must be together before the tape is applied.

Using an M10 cam lock handle and an M10 flat washer, attach the bracket to the Jeep. Snug hardware, but do not fully tighten.

Repeat this process for the three remaining attachment points.

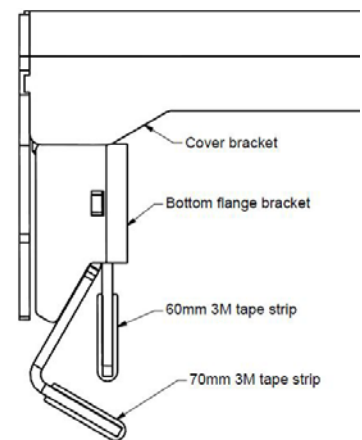

### Step 3

Once snug, align the cross tubing with the brackets and attach with an M12 button head cap screw, lock washer, flat washer and locking bracket.

Snug hardware, but do not fully tighten.

Repeat this process for the three remaining attachment points.



#### Step 4

After all brackets are snug, proceed to fully tighten with an M8 allen wrench.



#### Step 5

To install a cargo basket, follow the basket manufacturer's instructions.

Once complete, adjust the brackets if needed to make sure cross tubing aligns with the basket. Tighten down the brackets with the cam handle.

#### **WARNING**

Do not over tighten the cam handle or it could cause cracking or breaking of the roof gutter. Periodically check to make sure the brackets are fully secured.



#### Step 6

Congratulations on the installation of your new CURT roof cargo brackets.

With the roof cargo brackets installed, periodic inspections should be performed to ensure all mounting hardware remains tight.

To protect your investment, see the 'Notes and Maintenance' section on page one.

