



PART 80199

# Installation Instructions

Adjustable Electric Fan Thermostat with  
3/8-NPT Brass Probe

The AFCO Adjustable Fan Thermostat allows the user to custom-tailor the turn-on temperature. It is factory preset at 160°; the adjustment range is 150° to 240°.

**NOTE: Before starting installation, read the instructions completely and disconnect the battery.**

## Fan Control Module Installation

The fan control module must be mounted in a cool, dry location, away from hot components. The temperature probe wires are 18" long, but can be lengthened to allow mounting the control box further from the radiator. When lengthening the probe wires, use good quality connectors and wire.

1. Using the mounting feet on the fan control module as a guide, mark and drill two 5/32" holes.
2. Use the two #10 metal screws provided to mount the control module.

## Temperature Probe Installation

1. The temperature probe must be inserted into a 3/8" NPT port in the engine or radiator. Often the intake manifold or cylinder heads have an available port.
2. The probe wires can be lengthened if necessary.

**NOTE: Thread sealant must be used when installing the probe and on the adapter, if used.**

## Temperature Adjustment

1. Turn the temperature adjustment counter-clockwise to lower the fan turn-on temperature.
2. Turn the temperature adjustment clockwise to raise the fan turn-on temperature.
3. The adjustment range is 3/4 of a turn. Do not force past the stop. Ensure that the vehicle is up to operating temperature before adjusting.

## WIRING DIAGRAM

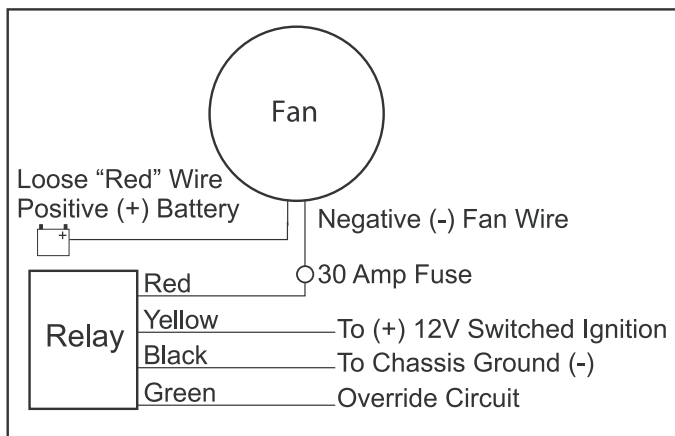

## Wiring

Before starting, disconnect the Negative (-) cable on the vehicles battery. Plug the wire harness into the Fan Control Module. Using the electrical connectors and wire ties provided, follow the instructions below. **See Wiring Diagram in left hand column.**

### Red (Loose wire): Positive (+) Battery to Positive (+) Fan Lead

Using the Yellow Ring Terminal provided, attach one end of the Red loose wire to the vehicle's Positive (+) terminal on the battery. Using the Blue Butt Connector provided, attach the other end of the loose Red wire to the Positive (+) lead on the electric fan.

### Red (Fused Harness wire): To Negative (-) Electric Fan Lead

Using the Blue Butt Connector provided, attach the Red wire to the Negative (-) lead on the electric fan. If you are running two small electric fans, the total continuous amperage cannot exceed 25 amps. The Red wire can be connected in parallel to both Negative (-) fan leads.

### Black Wire: Chassis Ground (-)

Using the Blue Ring Terminal provided, attach the black wire to a good chassis ground.

### Yellow Wire: Switched Ignition source

Using the Red Butt Connector provided, attach the yellow wire to a positive (+) switched ignition source.

**NOTE: If the yellow wire is connected to a constant power source (battery) the electric fan will run after the vehicle is shut off and could run down the battery.**

### Green Wire: Override Circuit (Optional)

The green wire is designed to work in two different configurations. When used, this will allow the fan(s) to be turned on regardless of the temperature of the thermostat as it simply overrides all other functions. If you choose to not use this option, cut any exposed copper and tape or shrink wrap the end of the wire.

1. A/C Override - Using the Blue Wire Tap provided, attach the green wire to the positive lead on the air conditioning compressor.
2. Manual Switch Override - Attach the Green Wire to the manual switch (not provided). For Manual Switch installation, always follow manufacturer's instructions.

## Bill of Materials

- 1 — Fan control module
- 1 — 30 Amp relay
- 1 — 25 Amp fuse
- 2 — #10 Phillips head screws
- 2 — 22 GA. red butt connector
- 1 — 14 GA. blue butt connector
- 1 — 14 GA. blue ring connector
- 1 — 22 GA. red ring connector
- 1 — 14 GA. blue splice connector