



AEROMOTIVE Part # 17140
INSTALLATION INSTRUCTIONS
Not For Street Use!

CAUTION:

Installation of this product requires detailed knowledge of automotive systems and repair procedures. We recommend that this installation be carried out by a qualified automotive technician.

Installation of this product requires handling of gasoline. Ensure you are working in a well ventilated area with an approved fire extinguisher nearby. Extinguish all open flames, prohibit smoking and eliminate all sources of ignition in the area of the vehicle before proceeding with the installation.

When installing this product, wear eye goggles and other safety apparel as needed to protect yourself from debris and sprayed gasoline.

WARNING!

The fuel system is under pressure. Do not open [the fuel system](#) until the pressure has been relieved. Refer to the appropriate vehicle service manual for the procedure and precautions for relieving the fuel system pressure.

Aeromotive system components are not legal for sale or use on emission controlled motor vehicles.

The enclosed Aeromotive fuel pump utilizes an o-ring sealed AN-10 style inlet and outlet ports; these ports are **NOT PIPE THREAD** and utilize **NO THREAD SEALANT**.

A high capacity 100 micron fuel filter must be installed between the fuel tank and pump inlet as well as a high capacity 10 micron fuel filter on the pump outlet. We recommend an Aeromotive P/N 12302 on the inlet side and an Aeromotive P/N 12301 on the outlet side. Call us for info.

To use this pump in your vehicle's fuel system, we strongly recommend the following:

Gravity feed the pump by mounting it lower than the fuel cell.

Utilize AN-10 size high pressure fuel lines, fittings and o-rings for all connections from the fuel cell to the engine.

Failure to follow the above recommendations may result in fuel leakage, bursting of the fuel lines, poor vehicle performance and/or decreased fuel pump life! Improper installation will void all warranties for this product!

Performance Specifications: Model 17140

Fuel Compatibility	Gasoline & Methyl Alcohol
Port Sizes	Inlet & Outlet AN-10

Pulley and Belt Information:

½" wide, 3/8" or "L" Pitch timing pulley and Belt
Pump speed must be ½ the engine speed.
Included Pump Pulley: 28-tooth
Recommended Crank Pulley: 14-tooth

Pump mounting:

Pump should be mounted as low as possible to ease priming.
Due to the large number of applications, no specific mounting instructions are provided.

The following steps are typical of most installations:

1. Once the engine has been allowed to cool, relieve the fuel system pressure and disconnect the negative battery cable.
2. Raise the vehicle and support it with jack stands.
3. Find a suitable place on the engine or chassis to mount the Aeromotive fuel pump. Make sure the location will accommodate the pump mounting bracket, will position the pump as low as possible, is clear of the exhaust, is clear of any moving suspension or drivetrain components and will keep the pump clear of track obstructions or debris.

Note: Be sure to route all fuel lines clear of any moving suspension or drivetrain components, and any exhaust components! Protect fuel lines from abrasion and track obstructions or debris.

4. Acquire a 14-tooth, 3/8" or "L" Pitch, 1/2" wide timing belt pulley for the crankshaft and a 1/2" wide timing belt of the desired length. See Table 1 for Typical Belt lengths.

Center Distance	# of Grooves	Belt length
5.37"	50	18.750"
5.94"	53	19.875"
6.51"	56	21.000"
7.26"	60	22.500"
7.64"	62	23.250"
8.02"	64	24.000"
8.40"	66	24.750"
8.77"	68	25.500"
9.15"	70	26.250"

Center Distance	# of Grooves	Belt length
9.53"	72	27.000"
9.90"	74	27.750"
10.28"	76	28.500"
11.03"	80	30.000"
11.41"	82	30.750"
11.78"	84	31.500"
12.16"	86	32.250"
12.53"	88	33.000"

This table assumes you have a 28 tooth pulley on the fuel pump and a 14 tooth pulley on the crank.

Table 1

5. Determine which direction the fuel pump shaft will rotate. The direction the shaft is rotated will determine which port is the inlet and which is the outlet. Using Figure 1a & 1b as a reference identify the fuel pump inlet and outlet ports. If the fuel pump shaft is rotated in a clockwise direction as viewed from the rear of the pump the inlet and outlet ports will be as shown in Figure 1a. If the fuel pump shaft is rotated in a counter-clockwise direction the inlet as shown in figure 1a now becomes the outlet and the outlet in figure 1a is now the inlet, this is shown in figure 1b.

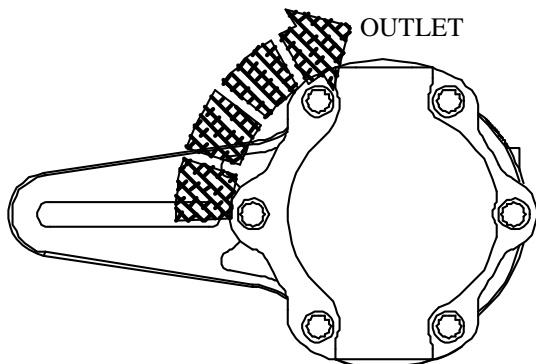

INLET

Figure 1a

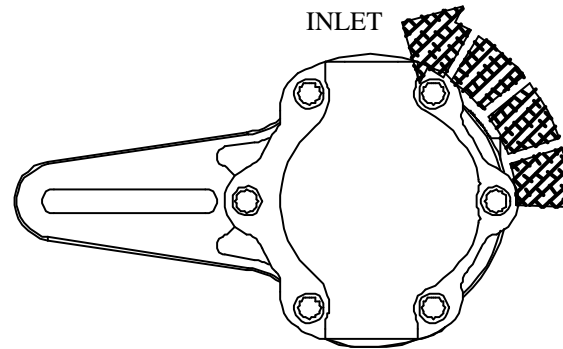

INLET

OUTLET

Figure 1b

6. Connect the fuel cell sump to the fuel filter inlet, we recommend using fuel filter Aeromotive p/n 12304 or 12302, utilizing a minimum of AN-10 steel braided fuel line. Next, connect the fuel filter outlet to the fuel pump inlet utilizing a minimum of AN-10 steel braided fuel line, refer to Figure 1 for determining the fuel pump inlet.
7. Connect the fuel pump outlet to the vehicle's fuel system. **Make sure you use high pressure (1000 psi minimum) fuel line for this connection!**

Note: Be sure to route all fuel lines clear of any moving suspension or drivetrain components, and any exhaust components! Protect fuel lines from abrasion and track obstructions or debris.

8. If you are using this fuel pump with an EFI style fuel system we recommend using Aeromotive p/n 13110 Fuel Pressure Regulator.
9. **Ensure that any spilled fuel and any fuel soaked shop towels are cleaned up and removed from the vicinity of the vehicle!**

CAUTION: While performing the following steps, if any fuel leaks are detected, immediately turn the ignition to OFF, remove any spilled fuel and repair the leak(s) before proceeding!

10. Turn the engine over **without starting the engine**, allow the pump to prime for several seconds and check the fuel pressure. If there is no pressure, wait one minute, then turn the engine over, recheck the pressure. Repeat this procedure until the gauge registers pressure or you detect a fuel leak.
11. Carefully lower the vehicle to the ground.
12. Test-drive the vehicle to insure proper operation and re-check the fuel system for leaks. **If any leaks are found, immediately discontinue use of the vehicle and repair the leak(s)!**