



## **AEROMOTIVE**

**Part # 14118**

**'97-'03 5.4L Ford F-150**

**'97-'02 5.4L Ford Expedition**

**'98-'03 5.4L Ford F-250 Super Duty**

### **INSTALLATION INSTRUCTIONS**

This product is not legal for sale or use on emission-controlled vehicles except when used as a direct replacement part matching OEM specification.

#### **WARNING!**



Always be aware of flammable situations. Drilling and grinding can be potential ignition sources. Extinguish all open flames, prohibit smoking and eliminate all sources of ignition in the area of the vehicle and workspace before proceeding with the installation. Ensure you are working in a well ventilated area with an approved fire extinguisher nearby.

#### **WARNING!**



etc.

Installation of this product requires modification to a fuel tank/ the fuel system, failure to satisfy all safety considerations will result in fire, explosion, injury and/or loss of life to yourself and/or others. All fuel system components **MUST** be located as far from heat sources as possible, like exhaust, engine block,

#### **WARNING!**



Mechanical and hydraulic lifting devices can tip over or lower accidentally due to incorrect maneuvering or technical errors. A falling object can cause injury and/or loss of life to yourself and/or others. When working under the vehicle, always use stands, and ensure that the ground or floor is stable and level. Never crawl under a vehicle which is only supported by a jack.

#### **WARNING!**



The fuel system is under pressure. Do not open the fuel system until the pressure has been relieved. Refer to the appropriate vehicle service manual for the procedure and precautions for relieving the fuel system pressure.

#### **CAUTION!**



When installing this product always wear safety glasses and other appropriate safety apparel. A drilling operation will cause flying metal chips. Flying metal chips can cause eye injury.

#### **CAUTION:**



Installation of this product requires detailed knowledge of automotive systems and repair procedures. We recommend that this installation be carried out by a qualified automotive technician. Careless installation of this product can result in damage to the product, injury or loss of life to yourself and/or others.

## Compatible Fuels:

Pump Gas  
Race Gas  
E85  
Alcohol/Ethanol

The enclosed Aeromotive fuel rails utilize o-ring sealed AN-08 style ports; these ports are **NOT PIPE THREAD** and utilize **NO THREAD SEALANT**. To use the enclosed fuel rails in your vehicle's fuel system you must install the necessary adapter fittings and o-rings, high pressure fuel lines and regulator to adapt your system to the configuration and ports of these fuel rails. Please call for a catalog of the complete line of quality Aeromotive products.

The enclosed Aeromotive fuel rails are intended to be installed on an unmodified OEM intake manifold of the identified application. Aeromotive cannot guarantee the proper fitment on aftermarket intake manifolds and the end user is responsible for verifying proper fitment and assumes all liability.

When installing o-rings it is important to place a small amount of light oil on both the o-ring and the mating surface to ease installation and prevent damaging the o-ring.

The following installation instructions are for a typical installation, for specific year and model installation instructions please refer to your vehicles service manual.

Aeromotive system components are not legal for sale or use on emission controlled motor vehicles.

### **Special tools needed:**

Fuel supply line quick disconnect tool  
Fuel return line quick disconnect tool

### **Supplies needed:**

Vehicle service manual  
Fuel injector replacement O-rings  
Light oil  
Solvent parts cleaner  
Clean shop towels

### **This kit contains the following parts:**

1ea p/n 14117 Ford 5.4L Fuel Rails	1ea AN-06 O-Ring
1ea p/n 13101 EFI Regulator	4ea AN-08 O-Ring
1ea p/n 15101 Bypass Adapter Fitting	2ea AN-10 O-Ring
1ea p/n 15102 Supply Adapter Tee Fitting	1ea p/n 15650 –6 Straight Hose End
4ea p/n 15607 AN-8/AN-8 Cutoff Tapered Flare Fitting	1ea p/n 15652 –6 90-Degree Hose End
2ea p/n 15610 AN-10/AN-8 Cutoff Tapered Flare Fitting	1ea p/n 15653 –8 Straight Hose End
1ea p/n 15606 AN-6/AN-6 Cutoff Tapered Flare Fitting	7ea p/n 15655 –8 90-Degree Hose End
	3ft –6 Stainless Steel Braided Fuel Line
	10ft –8 Stainless Steel Braided Fuel Line

### **The following steps are typical of most installations:**

1. Once the engine has been allowed to cool, disconnect the negative battery cable and relieve fuel system pressure, referring to the appropriate vehicle service manual for the procedure on doing so.
2. Remove the air intake ducting from the throttle body and position it out of the way.
3. Check for any dirt or debris around the fuel injectors. If any is evident, wash it off with some solvent parts cleaner or wipe it off with a clean shop towel.
4. Disconnect the electrical connector at each injector, making note of the location of each.

5. Disconnect both the supply and return fuel lines from the OEM fuel rails. These lines are attached by a special quick disconnect fitting which requires a special tool for removal. Place clean shop towels around the open fuel lines to catch any gasoline that may drip out and to prevent any dirt from entering the fuel lines.

**Failure to satisfy all safety considerations will result in fire, explosion, injury and/or loss of life to yourself and/or others.**

6. Label and disconnect any electrical wiring, vacuum lines and throttle body components that will interfere with the fuel rail removal and installation.
7. Remove the 4 mounting bolts that attach the fuel rail to the intake manifold.
8. Place clean shop towels around the injectors to catch any gasoline that may be spilled during their removal. Remove the injectors from the manifold by gently pulling upward on the fuel rail / injector assembly. Keep all injectors connected to the fuel rails. If an injector does pull out of the fuel rail, it may spill a large amount of gasoline.

**Failure to satisfy all safety considerations will result in fire, explosion, injury and/or loss of life to yourself and/or others.**

9. Carefully remove the fuel injectors from the OEM fuel rail.
10. Remove the old o-rings from the fuel injectors, inspect the injectors for any dirt or debris and clean if needed. It is suggested that the old o-rings be replaced, contact your local parts store or dealer to purchase the correct replacement o-rings.
11. Carefully install the new injector o-rings on the injectors.

**When installing o-rings it is important to place a small amount of light oil on both the o-ring and the mating surface to ease installation and prevent damaging the o-ring.**

12. Place a thin coat of light oil in the fuel rail injector bores and in the lower intake manifold injector bores to help prevent cutting the o-rings during installation.
13. Carefully place the fuel injectors in the fuel rails (depending on vehicle, placing the injectors in the intake first might ease installation). Position the electrical connector on each fuel injector to the opposite side of the fuel rail as the mounting bracket.
14. Install the driver side fuel rail, being careful not to cut any of the o-rings during installation. The driver side fuel rail will have a wider bracket spacing than the passenger side.
15. Install the passenger side fuel rail, being careful not to cut any of the o-rings during installation.
16. Find suitable place in the vehicle's engine compartment to mount the Aeromotive regulator, typically on the driver side wiring harness cover. This is located above the driver side fuel rail. Using the supplied mounting bracket as a template, mark the bracket mounting holes and drill to accept a #10 screw.
17. With the bracket attached to the regulator, mount the bracket and regulator to the vehicle using two #10 screws, nuts and lock washers.
18. Install one AN-10 o-ring on the port (cut-off) side of each of the two of the P/N 15608 ORB-10/AN-8 port fittings and one o-ring on the port (cut-off) side of P/N 15606 ORB-06/AN-06 union fitting.
19. Thread the port (o-ring) side of the P/N 15608 port fitting into each of the two AN-10 ports on the regulator. Also thread the port (o-ring) side of the P/N 15606 fitting into the bottom of the regulator.

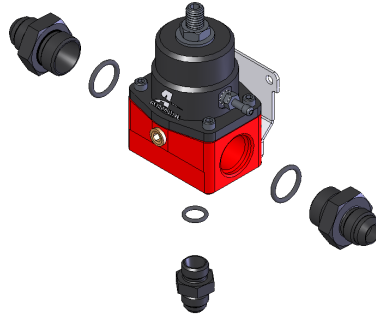

20. Install one AN-08 o-ring on the port (cut-off) side of each of the four P/N 15607 ORB-08/AN-08 port fittings.

21. Thread the o-ring side of each P/N 15607 fitting into the front and back ports of each fuel rail.

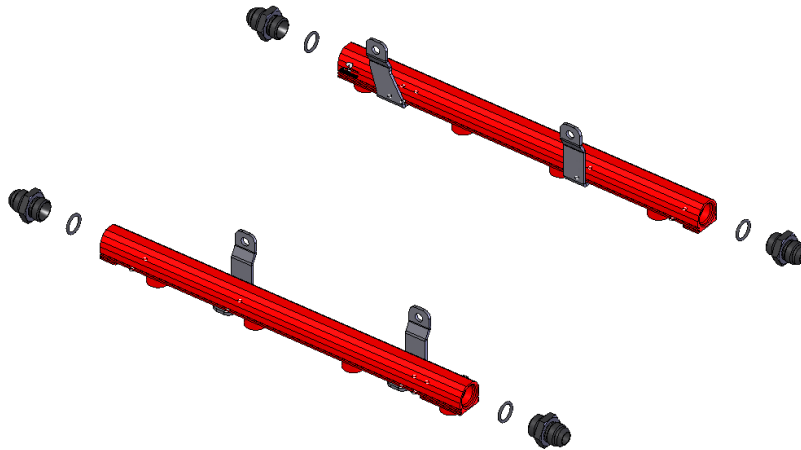

22. Inspect the o-rings on the OEM quick disconnect fitting for both supply and return line and replace if necessary. Coat o-rings and the adapter fitting with a light oil and install the P/N 15101 AN-06 / Ford quick disconnect adapter fitting on the OEM return (bypass) fuel line.

**Please note if installing a high performance fuel pump, (Similar to Aeromotive P/N 11101) the OEM return line will be too restrictive to handle the volume of fuel that these pumps are capable of pumping. To prevent losing lower pressure adjustability of your regulator it will be necessary to replace the OEM return line with a 3/8" ID (AN-06) return line in these cases.**

23. This kit contains one AN-06 straight hose end which will connect to the 15101 return line adapter fitting, and one AN-06 90 degree hose end to connect to the AN-06 port fitting on the bottom of the fuel pressure regulator. With these fittings in place, measure the length of fuel line needed. See section titled Hose and Fitting Assembly for fuel line assembly instructions. Once the hose and hose-ends are assembled, **ensure there is no debris in the hose** and install it.

24. A typical application looks similar to the picture shown below.

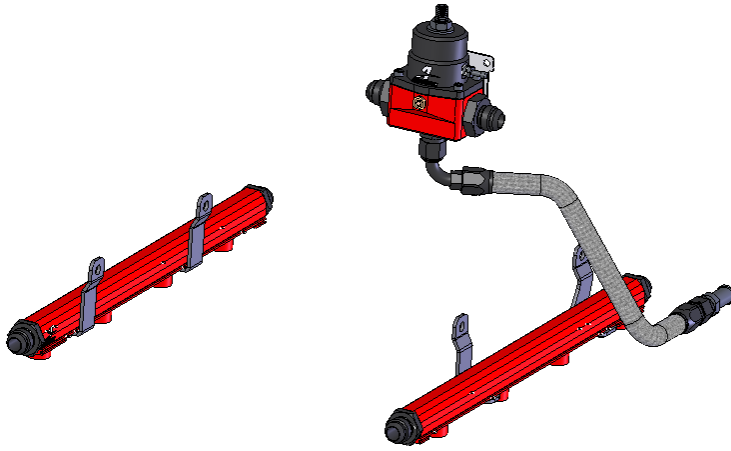

25. Connect one AN-08 90-degree hose end to each of the two P/N 15610 port fittings in the fuel pressure regulator. Connect one AN-08 90-degree hose end to each of the P/N 15607 port fittings in the fuel rails. Plan a route for each of the two lines between the fuel pressure regulator and the fuel rails, measure the two lengths of fuel line needed. See section titled Hose and Fitting Assembly for fuel line assembly instructions. Once the hoses are assembled, **ensure there is no debris in the hose** and install them.

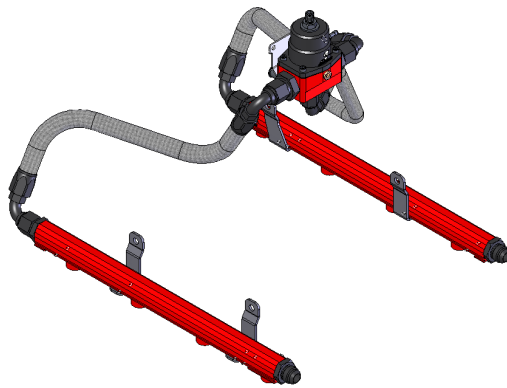

26. Inspect the OEM fuel supply line o-rings and replace if necessary. Place a light coat of oil on the fuel supply line o-rings and the supply line adapter fitting to ease installation. Connect the P/N 15102 OEM Spring Lock to AN-08 tee adapter fitting onto the OEM fuel supply line.
27. Using the remaining AN-08 hose ends as a guide (see diagram below), measure the required fuel line lengths needed and make up the last two required AN-08 fuel supply lines (See section titled Hose and Fitting Assembly). A typical configuration is pictured below.

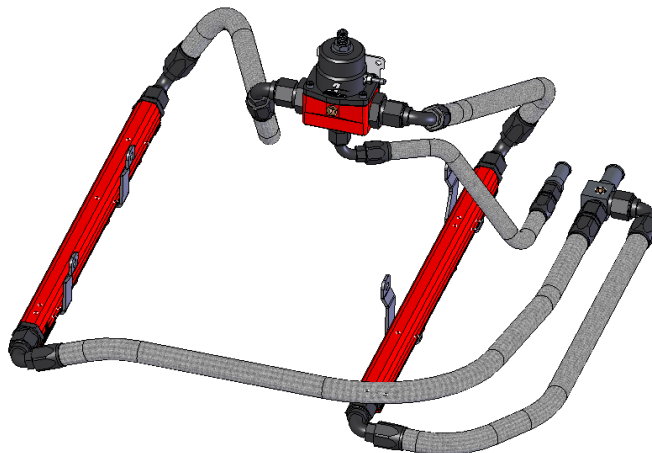

28. Reassemble the vehicle using the reverse of the foregoing removal procedure.

29. Remove the 1/8 NPT pipe plug from either the fuel pressure regulator or fuel supply adapter tee fitting and attach a suitable fuel pressure gauge.

**Ensure that any spilled gasoline and any gasoline soaked shop towels are cleaned up and removed from the vicinity of the vehicle!**

33. Reconnect the battery and turn the ignition to the ON position **WITHOUT** starting the car. After several seconds, check the fuel pressure. If there is no fuel pressure, turn the ignition key to the OFF position, wait one minute, return the ignition to the ON position, and recheck the fuel pressure. Repeat this ignition OFF and ON procedure until the fuel pressure gauge registers fuel pressure.

**With the fuel pressure gauge registering fuel system pressure, check for fuel leaks from and around the Aeromotive regulator, fuel rails, all fuel lines and connections! If any fuel leaks are found, turn the ignition key to the OFF position, remove any spilled fuel and repair the leak before proceeding!**

34. Once the fuel pressure gauge registers fuel system pressure and there are no fuel leaks, start the engine and adjust the regulator to the desired fuel pressure. Turning the adjustment screw clockwise will increase fuel pressure. OEM regulators are typically set at approximately 43 psi, without the vacuum line attached. The fuel pressure adjustment range for this regulator is 35-75 psi and we recommend setting the static pressure (no vacuum) at 40 psi.

**Due to the confined nature of modern OEM vehicles Aeromotive realizes that the fuel pressure regulator may be inconvenient to adjust in some applications. We feel that this small inconvenience is worth it in providing you with an optimal fuel system.**

35. Once the desired fuel pressure is achieved, tighten the regulator adjustment jam nut and attach the vacuum line.

36. Turn off the engine and allow it to cool. If you do not want to keep the fuel pressure gauge on the vehicle, relieve the fuel system pressure as instructed in the appropriate vehicle service manual. Remove the fuel pressure gauge and reinstall the 1/8 NPT pipe plug, using thread sealant.

**37. Test drive the car to insure proper operation and re-check the fuel system for leaks. If any leaks are found, immediately shutoff the engine and repair the leak(s)!**