



# *Adjustable Fuel Pressure Regulator*

Installation Instructions for:

Part Numbers

25-300

25-301

25-303

25-304

U.S. Patent # 6,298,828



**WARNING:**

Due to the fact that this installation deals with your fuel system this installation is not for the mechanically challenged! If you are not mechanically inclined or do not understand the procedure please do not attempt the installation. Refer the installation to a reputable mechanic.

This part is legal in California for racing vehicles ONLY and should NEVER be used on public highways.

**Congratulations!** You have just purchased the finest adjustable fuel pressure regulator for your car at any price!

**AEM billet aluminum adjustable pressure regulator.**

The AEM adjustable regulator bolts directly to the stock Honda or the AEM high volume fuel rail. It is CNC machined from 6061 T-6 aluminum. The fuel outlet port is tapped to 9/16-18 threads, which allows the use of several different hoses ranging from the stock Honda fuel return hose to -8 AN hose. The vacuum reference is 1:1 ratio so for every pound of boost on a turbocharged or supercharged application yields a 1-pound rise in fuel pressure. The range of adjustability is from 20 PSI to the maximum the fuel pump can deliver.

A unique feature of the AEM adjustable pressure regulator is that the discharge port in the regulator is changeable. This allows the user to tailor the regulator return volume to match their fuel pump. A common problem that occurs when using a fixed orifice in a “universal” regulator is that the fuel pressure cannot be effectively controlled when the fuel pump volume is significantly higher than stock. In the case of too small of a discharge orifice, there is a large pressure spike associated with rapid deceleration because the orifice cannot flow enough fuel when the diaphragm is fully deflected to the open position. This causes a momentary rich condition, which may lead to a rough idle quality until the pressure stabilizes. Conversely if the discharge orifice is too large the adjustment is difficult because the response of the fuel flow out of the orifice is too rapid which makes the adjustment screw too sensitive. The AEM regulator is packaged with three orifice sizes, .100”, .150” and .200”. They are easily changed by removing the diaphragm, unscrewing the orifice, and replacing it with the desired size orifice. The size range provided with the kit is enough to cover any pump from a stock Honda pump to the largest after-market pump available. The replaceable orifices are color coded for easy identification.

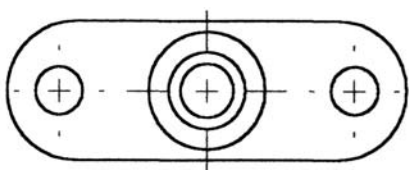

Inline  
Base

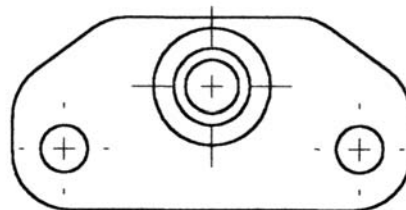

Offset  
Base

**Note:** Honda uses two styles of fuel pressure regulator bases. Before proceeding with your installation please compare the fuel pressure regulator on your vehicle and your new AEM adjustable fuel pressure regulator with the above diagrams.

**Bill of Materials for 25-300:**

2	2-609	-6 to 7mm Barb Fuel Return Fitting
1	2-611	Vacuum Fitting
1	2-612	Spring Cap
1	2-698	.250ORIFICE,BALLPRESSREG
1	2-697	.175ORIFICE,BALLPRESSREG
1	2-696	.1OrificeBALLPRESSREG
1	2-8000	Fuel Pressure Regulator Top
1	2-8100	Fuel Pressure Regulator Bottom (Inline)
1	1-3007	Crush Washer
1	1-3010	O-Ring
6	1-2023	Socket Bolt, SS 8-32 x 5/16"
1	1-2021	Socket Screw, SS 10-32 x 1"
1	1-2022	Nut, Jam SS 10-32
1	2-301	Diaphragm
1	1-122	Spring
2	1-2045	Socket Bolt, SS M6 x1 x 12mm
2	1-3016	Washer, SS M6

**Bill of Materials for 25-301:**

1	2-609	-6 to 7mm Barb Fuel Return Fitting
1	2-611	Vacuum Fitting
1	2-612	Spring Cap
1	2-613	0.20" Orifice
1	2-614	0.15" Orifice
1	2-615	0.10" Orifice
1	2-8000	Fuel Pressure Regulator Top
1	2-8101	Fuel Pressure Regulator Bottom (Offset)
1	1-3007	Crush Washer
1	1-3010	O-Ring
6	1-2023	Socket Bolt, SS 8-32 x 5/16"
1	1-2021	Socket Screw, SS 10-32 x 1"
1	1-2022	Nut, Jam SS 10-32
1	2-300	Diaphragm
1	1-122	Spring
2	1-2045	Socket Bolt, SS M6 x1 x 12mm
2	1-3016	Washer, SS M6

**Bill of Materials for 25-303:**

1	2-610	-6 to 7mm Nipple
1	2-635	-6 Banjo Bolt
1	2-611	Vacuum Fitting
1	2-612	Spring Cap
1	2-698	.250 Orifice
1	2-697	.175 Orifice
1	2-696	.1 Orifice
1	2-8000	Fuel Pressure Regulator Top
1	2-8100	Fuel Pressure Regulator Bottom (Inline)
2	1-3007	Crush Washer
1	1-3010	O-Ring
6	1-2023	Socket Bolt, SS 8-32 x 5/16"
1	1-2021	Socket Screw, SS 10-32 x 1"
1	1-2022	Nut, Jam SS 10-32
1	2-300	Diaphragm
1	1-122	Spring
2	1-2045	Socket Bolt, SS M6 x1 x 12mm
2	1-3016	Washer, SS M6

**Bill of Materials for 25-304:**

1	2-610	-6 to 7mm Nipple
1	2-635	-6 Banjo Bolt
1	2-611	Vacuum Fitting
1	2-612	Spring Cap
1	2-613	0.20" Orifice
1	2-614	0.15" Orifice
1	2-615	0.10" Orifice

1	2-8000	Fuel Pressure Regulator Top
1	2-8101	Fuel Pressure Regulator Bottom (Offset)
2	1-3007	Crush Washer
1	1-3010	O-Ring
6	1-2023	Socket Bolt, SS 8-32 x 5/16"
1	1-2021	Socket Screw, SS 10-32 x 1"
1	1-2022	Nut, Jam SS 10-32
1	2-300	Diaphragm
1	1-122	Spring
2	1-2045	Socket Bolt, SS M6 x1 x 12mm
2	1-3016	Washer, SS M6

Read and understand these instructions **BEFORE** attempting to install this product

## **WARNING!!!**

- **Do not smoke while working on the fuel system.**
- **Keep open flames or sparks away from your work area.**
- **Be sure to relieve fuel pressure while engine is off.**

**Note:** 1990-1993 Honda Accord and 1992-2000 Honda Prelude require the use of the *AEM Hi-Flow Fuel Rail* P/N 25-104. The AEM Adjustable Fuel Pressure Regulator can **NOT** be used with the stock fuel rail on these applications.

**Note:** Refer to attached table of applications to determine the correct *AEM Adjustable Fuel Pressure Regulator Kit* that is required for your year/model vehicle.

### **1) Getting started**

- a) Make sure vehicle is parked on a level surface.
- b) Set parking brake.
- c) **Disconnect the negative cable from the negative battery terminal.**
- d) If engine has run within the past two hours let it cool down.
- e) Clean the area on the fuel rail adjacent to the regulator.

**Note:** It is recommended to replace the washer between the service bolt and the special banjo bolt whenever the service bolt is loosened. (where equipped)

### **2) Relieving fuel pressure**

- a) Remove the fuel fill cap.
- b) **On models equipped with a 6mm service bolt. (Illustrated below) If your vehicle is not equipped with a 6mm service bolt, proceed to step c.**
  - i) Use a box end wrench on the 6mm service bolt on top of the fuel filter, while holding the special banjo bolt with another wrench.
  - ii) Place a rag or shop towel over the 6mm service bolt.
  - iii) Slowly loosen the 6mm service bolt one complete turn.
  - iv) Leave service bolt loose until all pressure has been relieved.
  - v) Tighten service bolt to 10 lbf-ft.

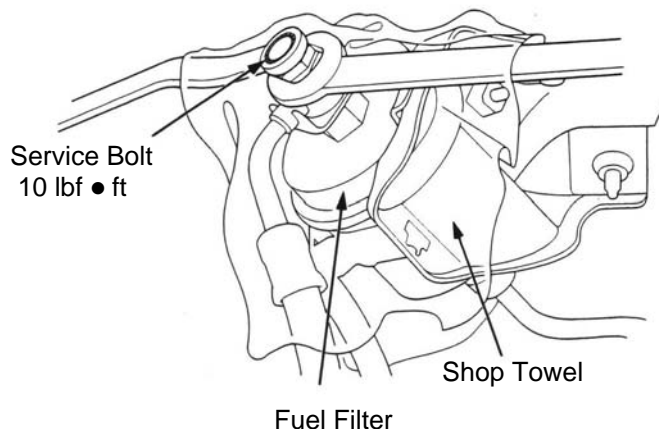

- c) **On models not equipped with a 6mm service bolt.**
  - i) Use a box end wrench on the 12mm banjo bolt on top of the fuel filter.
  - ii) Place a rag or shop towel over the 12mm banjo bolt.
  - iii) Slowly loosen the 12mm banjo bolt one complete turn or until all pressure has been relieved.
  - iv) Torque the 12 mm banjo bolt to 25 lbf-ft.

### 3) Stock fuel pressure regulator removal

- a) Place a rag or shop towel under the fuel pressure regulator return line.
- b) Disconnect the fuel return line at the bottom of the stock fuel pressure regulator.
- c) Disconnect the vacuum hose from the stock fuel pressure regulator.
- d) Place a rag or shop towel over the fuel pressure regulator.
  - i) Remove the two 6mm retaining bolts.
  - ii) Remove the fuel pressure regulator from the vehicle.

### 4) Installation of the AEM adjustable fuel pressure regulator

**Note: The AEM fuel pressure regulator has the .100" orifice installed in the regulator and is set to 40psi. All adjustments of the pressure regulator will be explained in a later portion of the instructions.**

#### WARNING!!!

The AEM adjustable fuel pressure regulator has been set to 40psi using a typical Honda fuel pump and a perfect running fuel system. Due to the differences on vehicle fuel pressure on different applications it is highly recommended that you adjust the fuel pressure on your vehicle. Refer to the last page of the instructions for the factory recommended fuel pressures.

- a) Remove and discard the two fuel pressure regulator caps used in packing.
  - i) Note: One cap is in the fuel inlet and one cap is on the fuel return.
- b) Install the fuel pressure regulator onto the fuel rail using the two allen bolts and washers supplied in the kit.

**Make sure that the o-ring is replaced and properly installed between the regulator and the fuel rail.**

  - i) Note: When installing the two allen head bolts a 5mm allen key should be used.
  - ii) Torque to 9 **lbf-ft**.
- c) Connect the vacuum hose to the top of the fuel pressure regulator. **On some vehicles incorporating a strut tower brace, it may be required to rotate the pressure regulator top to clear vacuum fitting.**
- d) Install the fuel return line fitting.
  - i) Use one crush washer when using the inline return fitting. Tighten to 20 **lbf-ft**. (Kits 25-300 & 25-301)
  - ii) Use two crush washers (one on each side of the fitting) when using the banjo angle return fitting. Tighten to 20 **lbf-ft**. (Kits 25-303 & 25-304)
    - (1) When using a kit with an angle return fitting, rotate the return nipple to match the fuel return line placement before tightening.
- e) Make sure that the rubber fuel return line is free flowing back to the fuel return hard line.
  - (1) Note: Ensure that there are no bends or kinks in the line that can restrict the fuel flow.
- f) Install any remaining components that were removed during disassembly.

### 5) Finishing touches

- a) Connect the negative battery terminal.
- b) Turn the ignition switch to the on position for approximately two seconds. **Do not operate the starter.** Then turn the ignition switch to the off position.
- c) Repeat this procedure three times, and then check all components that were removed during installation for any signs of fuel leakage.
- d) If there are signs of leakage you **MUST** correct the leak before proceeding.
- e) If there are no signs of leakage, then start engine and again check for leaks. If there is any sign of leaking you **MUST** repair the leak before driving the vehicle.
- f) **Note: To check the fuel pressure, start the engine. Measure the fuel pressure with the engine idling and vacuum hose of the fuel pressure regulator disconnected from the fuel pressure regulator and pinched. Set the AEM adjustable fuel pressure regulator to recommended settings on the last page of the instructions.**

### 6) Pressure and orifice adjustments

**Note: The AEM adjustable fuel pressure regulator can be fine tuned for your application. These adjustments will be covered in this section. A fuel pressure gauge needs to be used for precise tuning.**

- a) When fuel pressure adjustments are to be made, loosen the jam nut on the top of the AEM fuel pressure regulator and either tighten or loosen the set screw.
  - i) When loosening the jam nut a 3/8" wrench should be used.
  - ii) When tightening or loosening the set screw a 3/32" allen key should be used.
    - (1) To increase fuel pressure turn the set screw in a clockwise rotation.
    - (2) To decrease fuel pressure turn the set screw in a counter-clockwise rotation.

- b) When orifice changes are to be made, remove the fuel pressure regulator using the steps in section 4 in reverse order. When this is completed, remove the six bolts from the top of the fuel pressure regulator and use a 3/8" socket to remove the orifice in the regulator and replace with a different size orifice.
- i) When removing the six bolts from the top of the fuel pressure regulator a 9/64" allen key should be used.
    - (1) Torque to 24 **lbf-in**.
    - (2) There is a constant pressure applied to the diaphragm by the spring inside the fuel regulator make sure parts do not get lost upon removal of these bolts.
  - ii) When ever the regulator is disassembled check the diaphragm for any wear and tear, which may cause a fuel pressure problem.
    - (1) If the diaphragm is damaged contact AEM to purchase a replacement diaphragm.
  - iii) When removing the orifice a 3/8" socket should to be used.
    - (1) Note: **Be careful not to scratch or damage the surface of the orifice in any way, as it is a precision ground surface for the diaphragm to seal on.**
    - (2) Torque to 10 **lbf-ft**.
    - (3) There are three different size orifices supplied in the AEM fuel pressure regulator kit, which are indicated by three different colors. Black = .100" Silver = .150" Gold = .200"
    - (4) Upon re-installation of the orifice use a light coat of oil on the threads to prevent galling.
  - iv) Re-assemble the fuel pressure regulator. Assembly diagram at the end of the instructions.

**Shown below is a typical installation picture that can be used for reference.  
Other applications are similar.**

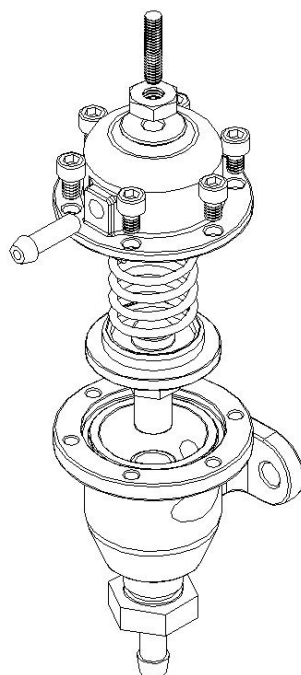
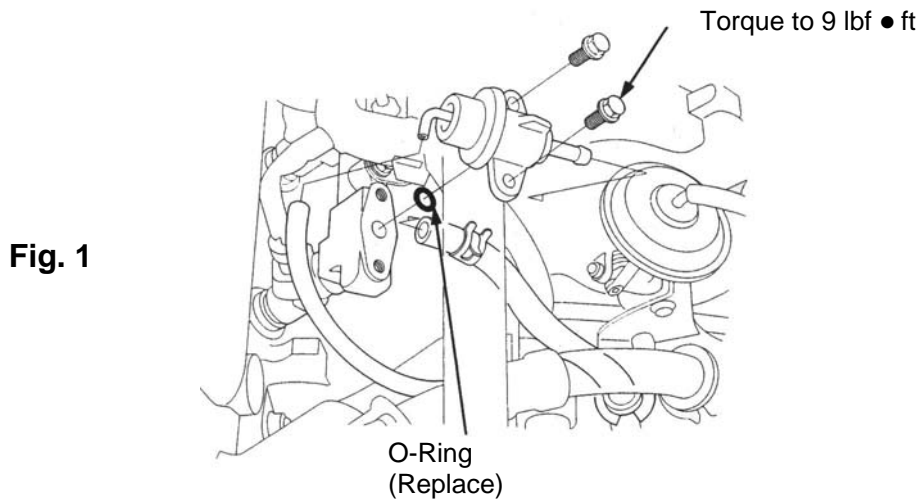



<b>Regulator Part #</b>	<b>Straight or Angle Return</b>	<b>Vehicle</b>	<b>Year</b>	<b>Model</b>	<b>Rec. Fuel Press</b>
25-300	Straight	Integra	94-2000	RS, LS, GS	40-47 PSI
25-300	Straight	Integra	94-2000	GSR, Type-R	48-55 PSI
25-300	Straight	Accord	88-89	LXI, SEI	36-41 PSI
25-300	Straight	Accord	90-91	All	35-41 PSI
25-300	Straight	Accord	92-93	All	40-47 PSI
25-300	Straight	Civic	92	All	40-47 PSI
25-300	Straight	Civic	92-95	All	40-47 PSI
25-300	Straight	Civic	99-00	SI	40-47 PSI
25-300	Straight	Del Sol	93-95	S, SI	40-47 PSI
25-300	Straight	Del Sol	94-97	VTEC	40-47 PSI
25-300	Straight	Prelude	88-91	SI	35-41 PSI
25-300	Straight	Prelude	92-96	S	40-47 PSI
25-303	Angle	Integra	86-89	All	35-41 PSI
25-303	Angle	Integra	90-91	All	35-41 PSI
25-303	Angle	Integra	92-93	Non-VTEC	41-48 PSI
25-303	Angle	Integra	92-93	VTEC	48-56 PSI
25-303	Angle	NSX	91-94	All	46-53 PSI
25-303	Angle	NSX	95-00	All	46-53 PSI
25-303	Angle	TL	95-98	4 Cyl.	43-50 PSI
25-303	Angle	TL	96-98	V6	38-45 PSI
25-303	Angle	Vigor	92-94	All	43-50 PSI
25-303	Angle	Civic	89-91	SI	40-47 PSI
25-303	Angle	Civic	90-91	EX	40-47 PSI
25-303	Angle	Civic CRX	88-91	HF, SI	40-47 PSI
25-303	Angle	Insight	00	All	40-47 PSI
25-300	Straight	Prelude	92-96	SI, SE	36-43 PSI
25-300	Straight	Prelude	92-96	VTEC	33-40 PSI
25-300	Straight	Prelude	97-00	All	40-47 PSI
25-301	Straight	CL	98-99	2.3L	47-54 PSI
25-301	Straight	Accord	98-00	4 Cyl.	47-54 PSI
25-301	Straight	Civic	96-00	DX, HX, CX, LX	40-47 PSI
25-301	Straight	CRV	99-00	All	40-47 PSI
25-301	Straight	Del Sol	96-97	S	40-47 PSI
25-301	Straight	S2000	00	All	47-54 PSI
25-304	Angle	CL	97	2.2L	41-48 PSI
25-304	Angle	Accord	94-97	4 Cyl.	41-48 PSI
25-304	Angle	Civic	96-00	EX	40-47 PSI
25-304	Angle	CRV	97-98	All	38-46 PSI
25-304	Angle	Del Sol	96-97	SI	40-47 PSI