



Equipped with AEM® Dryflow™ Filter
No Oil Required!

INSTALLATION INSTRUCTIONS

PART NUMBER:600-0200

2011-12 HONDA CR-Z L4-1.5L SEE * NOTE

PARTS LIST

	Description	Qty.	Part Number
A	Mid Pipe Assy.	1	83034
B	Rear Pipe and Muffler Assy.	1	83035
C	Gasket; 2.21" ID Flange	2	RM-CB84
D	Bolt; M10 x 1.25 x 25mm Flange, Brite Zinc	3	RHBA-M10X125X25
E	Nut; M10x1.25 Brite Zinc	6	RHNA-M10X125

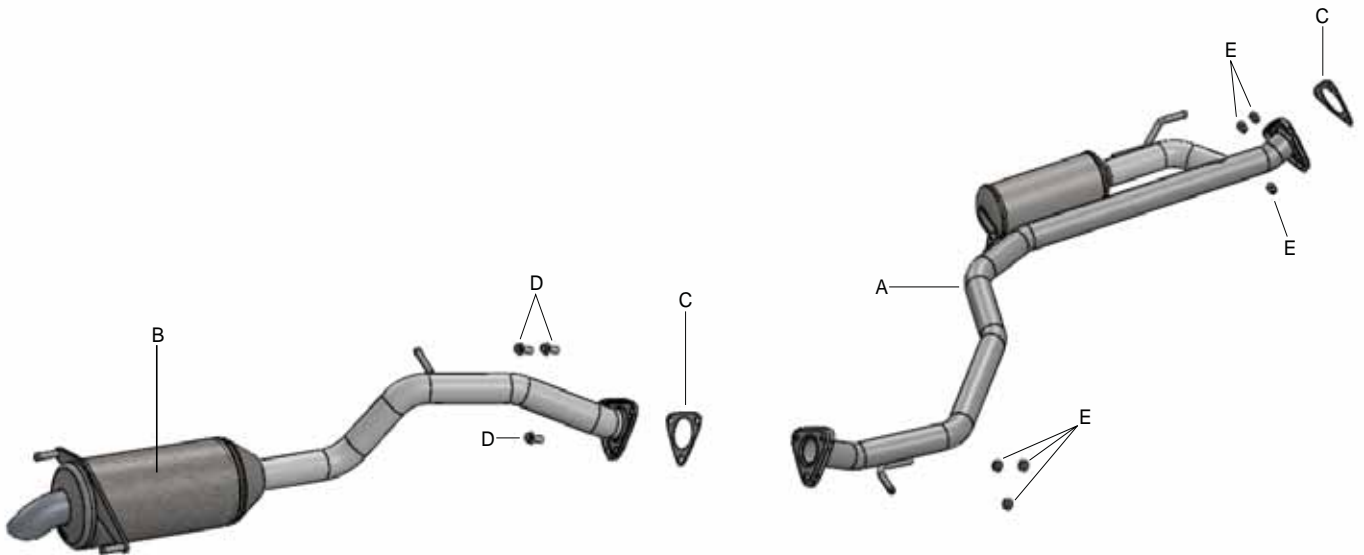

Read and understand these instructions **BEFORE** attempting to install this product. Failure to follow installation instructions and not using the provided hardware may damage the exhaust system.

1. Preparing Vehicle

- a. Make sure vehicle is parked on level surface.
- b. Set parking brake.
- c. If engine has run in the past two hours, let it cool down.
- d. Raise the front and rear of the vehicle with a jack. Refer to your owner's manual for proper jack and jack stand placement to properly support vehicle. Support your vehicle using properly rated jack stands before wheel removal or while working under the vehicle.

NEVER WORK UNDER A VEHICLE WITHOUT USING JACK STANDS.

2. Removal of stock system



a. Remove the 3 nuts securing the OEM mid pipe to the catalytic converter.



b. Remove the 2 bolts securing the OEM rear section to the mid pipe.



c. Remove the rear section by disengaging the two rubber mounts.



d. Disengage the rear most rubber mount on the mid pipe by sliding it off of the mount on the vehicle's side.



e. Disengage the remaining two rubber mounts and remove the mid pipe from the vehicle.



f. Remove the rear most rubber mount from the mid pipe as shown. Silicone spray will help with the removal.

3. Installation of AEM® exhaust system.

a. When installing the exhaust system, do not completely tighten the mounting hardware until instructed to do so.



b. Install the OEM rubber mount removed in step 2f, onto the rear section of the AEM® exhaust (83035) as shown.



c. Install the rear section of the AEM® exhaust (83035) as shown, by engaging the two rubber mounts at the muffler.



d. Engage the third rubber mount as shown.



e. Bend the emergency brake bracket up out of the way as shown.



f. Install the supplied gasket (RM-CB84) on the OEM catalytic converter as shown.



g. Install the AEM® mid pipe (83034) as shown by engaging the two rubber mounts.



h. Install the supplied gasket (RM-CB84) between the AEM® mid pipe, and rear section. Hold it in place with the 3 supplied M10 bolts (RHBA-M10X125X25) and nuts (RHNA-M10X125).



i. Secure the mid pipe to the OEM catalytic converter with the three supplied M10 nuts (RHNA-M10X125).



j. Align for best fit, and then tighten all bolts and nuts.

4. Reassemble Vehicle

- a. Position the exhaust pipes for the best fitment. Be sure that the exhaust pipes or any other components do not contact any part of the vehicle. Tighten all the bolts and nuts.
- b. Check for proper clearance. Re-adjust exhaust pipes if necessary and re-tighten them.
- c. To prevent permanent staining of your new exhaust system, wipe the exhaust tubes and muffler with a solution of mild detergent and water before starting the engine. Any contaminants left on the exhaust system such as grease, oil, and / or fingerprints will result in **PERMANENT** staining.
- d. Let the vehicle idle for 3 minutes. Re check bolts after vehicle has cooled for 1 hour.
- e. You may instantly see smoke coming from the exhaust both from inside and outside the system. This is normal as there may be residual oils in or on the exhaust system from the manufacturing process.
- f. Let the vehicle idle for 3 minutes. Perform a final inspection before driving the vehicle.