



Equipped with AEM® *Dryflow™ Filter*
No Oil Required!

INSTALLATION INSTRUCTIONS

PART NUMBER: 24-6005

1992-2001	HONDA	Prelude L4-2.2L	C.A.R.B. E.O. # D-670
1992-1996	HONDA	Prelude L4-2.3L	C.A.R.B. E.O. # D-670

PARTS LIST

Description	Qty.	Part Number	Additional Notes
Air Filter Assy. 4.00 X 5" Dry Ele.	1	21-205DK	
Inlet Pipe	1	2-60051	
Hose, Silicone 2.75x3" Blk.	1	5-275	
Hose; 3/8"ID X 10"L	2	5-1010	
Mount, Rubber 1" X 6mm	1	1228599	
Vacuum Cap, 1/8"	2	8-105	
Spacer, 1.00 OD .256 ID X 1"	1	2-658	1992-1996 models only
Hose; 5/32"ID X 9"L	1	5-3009	1992-1996 models only
Bracket	1	2-677	1992-1996 models only
Bolt, Hex/Flange M6-1 X 40	1	1-2075	1992-1996 models only
Washer, 6mm Soft Mount	2	559999	
Nut, M6 Hex Serrated	2	444.460.04	
1/2" Bnd. Hose Clamp, 3.56"-4.50"	1	9464	
1/2" Bnd. Hose Clamp, 2.31-3.25"	2	9444	
Hose Clamp, 3/4"	4	4093-5	

Read and understand these instructions **BEFORE** attempting to install this product. Failure to follow installation instructions and not using the provided hardware may damage the intake tube, throttle body and engine.

1. Preparing Vehicle

- a. Make sure vehicle is parked on level surface.
- b. Set parking brake.
- c. If engine has run in the past two hours, let it cool down.
- d. Disconnect negative battery terminal.
- e. Make sure you have the anti-theft code for the radio.
- f. Do not discard stock components after removal of the factory system.

2. Removal of stock system



- a. Factory air box configuration.

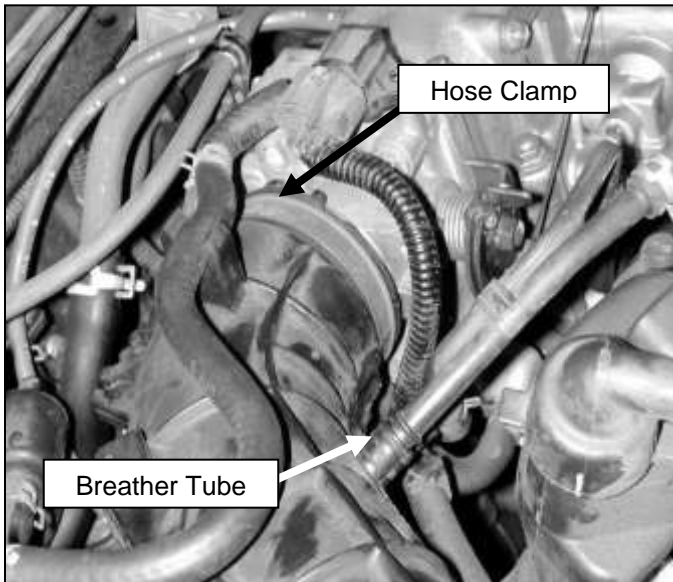

b. Disconnect the breather tube from the OE air inlet tube. On 92-96 models, remove the small breather tube from the top of the OE air inlet tube. The tube is inserted into a rubber boss on the inlet tube. Loosen the hose clamp holding the air inlet tube to the throttle body. Remove the air inlet tube by sliding it off the throttle body and pulling it off the air filter housing.

c. **CAUTION: Ensure the engine is completely cool before removing the coolant hose, or hot coolant will escape from the cooling system and cause injury or damage. Be sure to capture any lost coolant in a clean container.**

Disconnect the water bypass hose from throttle body located at the lower portion of the throttle body. Disconnect the opposite side of the water bypass hose, which runs to either the intake manifold. Remove the entire water bypass hose and breather hose assembly from the vehicle.

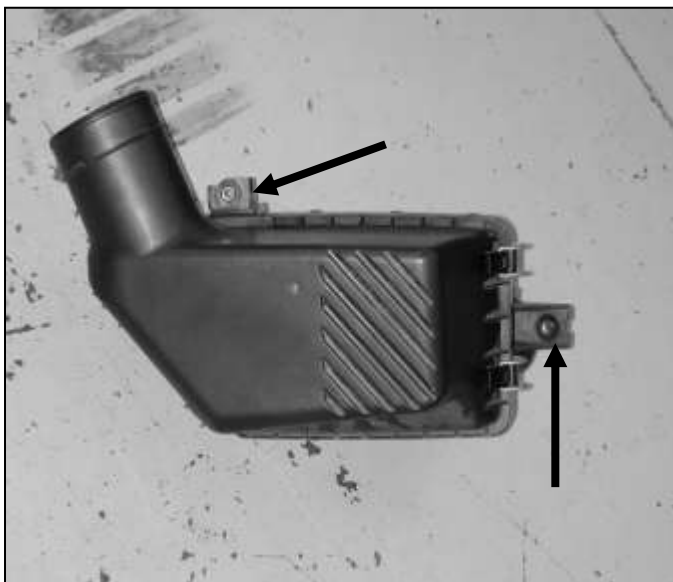

d. Unbolt the two bolts holding the air filter housing to the chassis. Lift and remove the air filter housing.

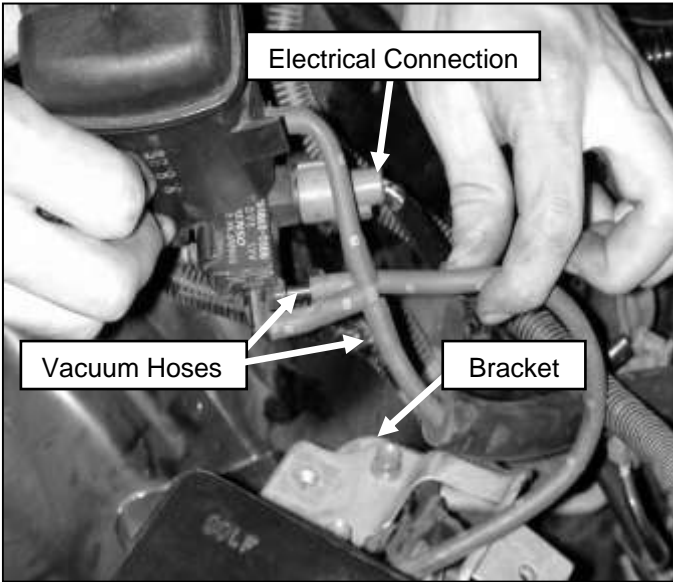

e. Disconnect the vacuum hoses and electrical connections that run to the Intake Air Control (IAC) solenoid valve. This valve controls the Intake Control Diaphragm (ICD). These components reduce the amount of intake noise generated in the stock system. AEM's intake system eliminates these components. Remove the IAC solenoid valve from the vehicle. For reference, the IAC solenoid valve is a little black box located behind the battery and underneath the stock inlet tube. Remove the aluminum bracket that mounts the IAC solenoid valve.

f. Remove the passenger side front wheel and remove the three bolts and the plastic push connector holding the splash shields in place. Move out of the way to expose the resonator box bolts.

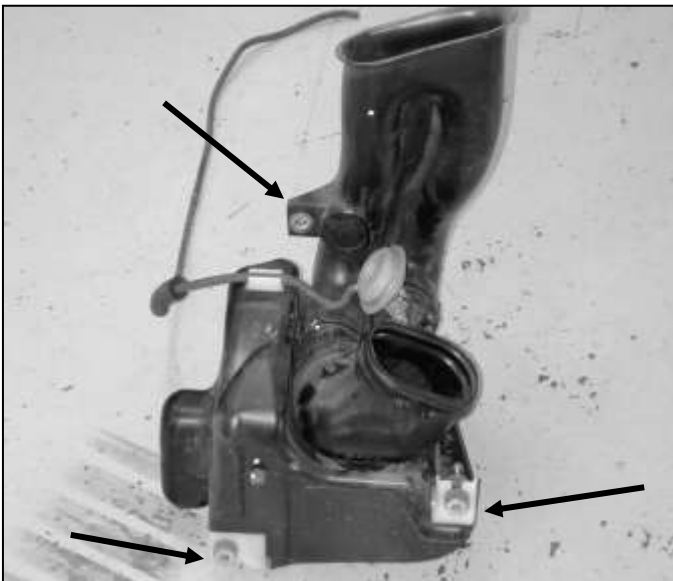

g. Remove the three bolts holding the resonator box in place. The third bolt is on top of the resonator box. Lower the box out of the car. Reinstall the splash shields and wheel. There will not be any more work done under the car.

h. Remove the rubber sleeve from inside the fender.

3. Installation of AEM® intake system (1997-2001 Prelude).

- a. When installing the intake system, do not completely tighten the hose clamps or mounting hardware until instructed to do so.

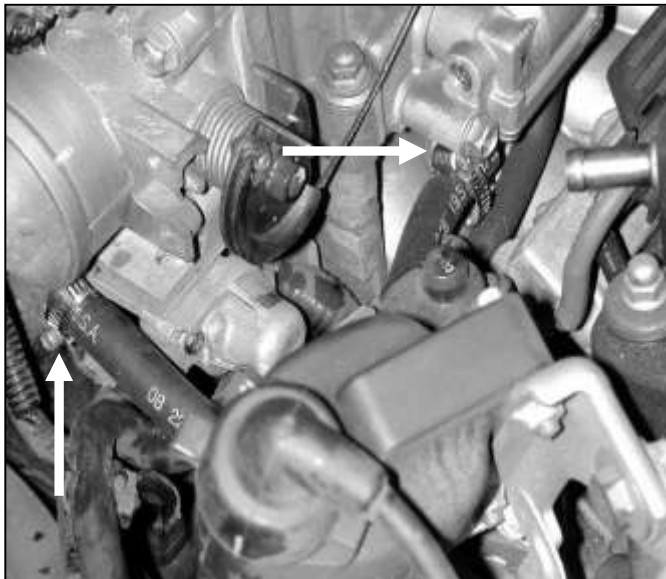

- b. Connect the new supplied water bypass hose and $\frac{3}{4}$ " hose clamps to the throttle body and the intake manifold where the factory water bypass hose was disconnected earlier.

- c. Install the 2.75" hose on to the throttle body using both #44 hose clamps. Check to see that the inside of the AEM® inlet pipe and air filter are clean and free from any foreign objects and/or obstructions.



- d. Thread the supplied rubber mount into the front hole where the aluminum bracket that mounted the IAC solenoid valve was located.

- e. Install the AEM® intake pipe into the 2.75" hose on the throttle body. The throttle body end is the end with the breather hose nipple.



f. Install the supplied 3/8" breather hose from the nipple on the intake pipe to the nipple on the valve cover. Use the supplied 3/4" hose clamps on the AEM® intake pipe nipple and on the valve cover nipple. Install the small rubber vacuum line plug on the manifold where the vacuum line from the IAC solenoid valve was removed.

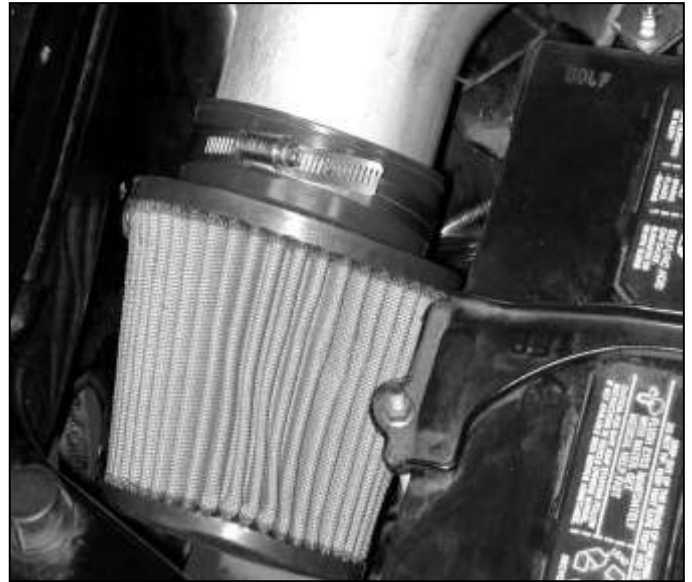

g. Slide the inlet pipe support over the rubber mount. Use the supplied washer and lock nut and assemble as shown. Do not tighten until the intake is properly fitted and is not touching anything in the engine bay. Next install the AEM® air filter onto the end of the inlet tube. Push the filter over the inlet pipe until it mates to the step inside the filter inlet. Install the supplied #64 hose clamp to secure the filter onto the inlet pipe. Tighten the hose clamp after this is done.

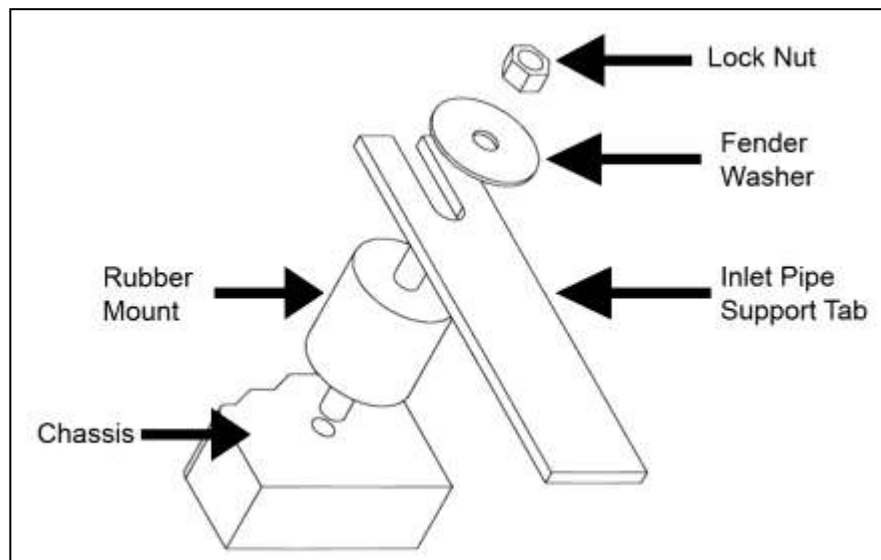

Rubber Mount Diagram



h. Check that the filter is not touching any part of the vehicle. Position the inlet pipe for best fitment. Be sure that the pipe or any other component is not in contact with any part of the vehicle. Tighten the hose clamps at the throttle body. Tighten the nut on the rubber mount. Check for proper hood clearance. Re-adjust pipe if necessary.

4. Installation of AEM® intake system (1992-1996 Prelude).

- a. When installing the intake system, do not completely tighten the hose clamps or mounting hardware until instructed to do so.



b. Connect the new supplied water bypass hose and $\frac{3}{4}$ " hose clamps to the throttle body and the intake manifold where the factory water bypass hose was disconnected earlier.



c. Install the 2.75" hose on to the throttle body using both #44 hose clamps. Check to see that the inside of the AEM® inlet pipe and air filter are clean and free from any foreign objects and/or obstructions.

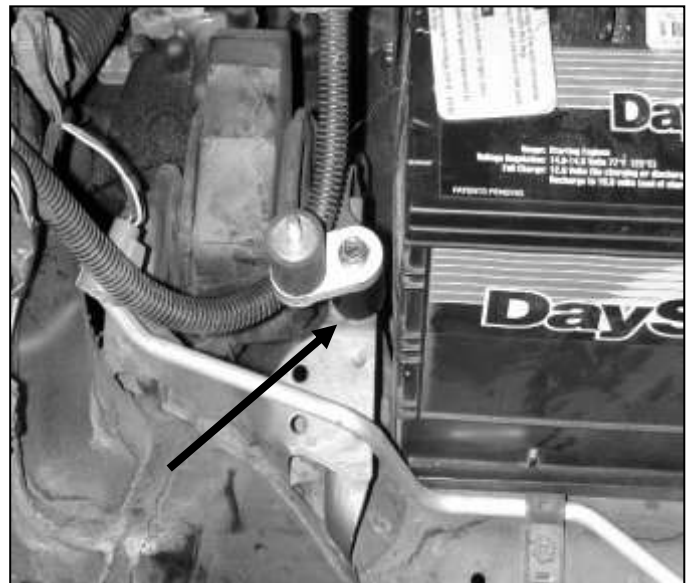
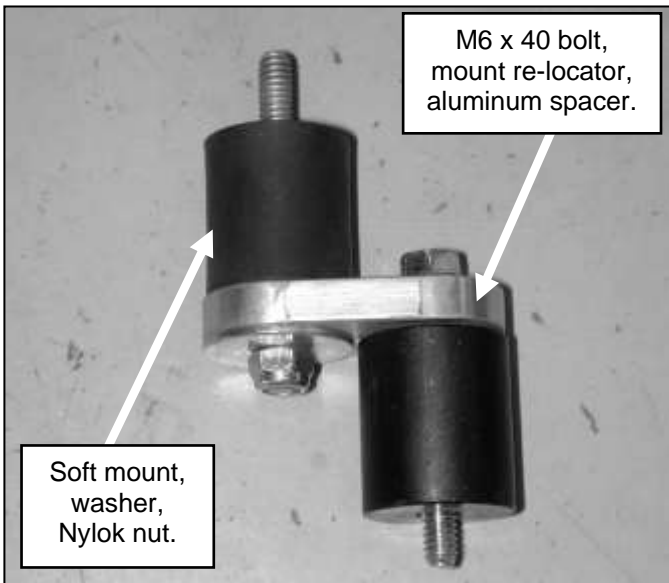

d. The intake mount assembly consists of; (1) aluminum spacer, (1) mount re-locator, (1) rubber soft mount, (1) M6 x 40 bolt, (1) washer, and (1) nylok nut. These should be assembled as shown above.

e. Install the intake mount assembly into the front hole where the aluminum bracket that mounted the IAC solenoid valve was located.

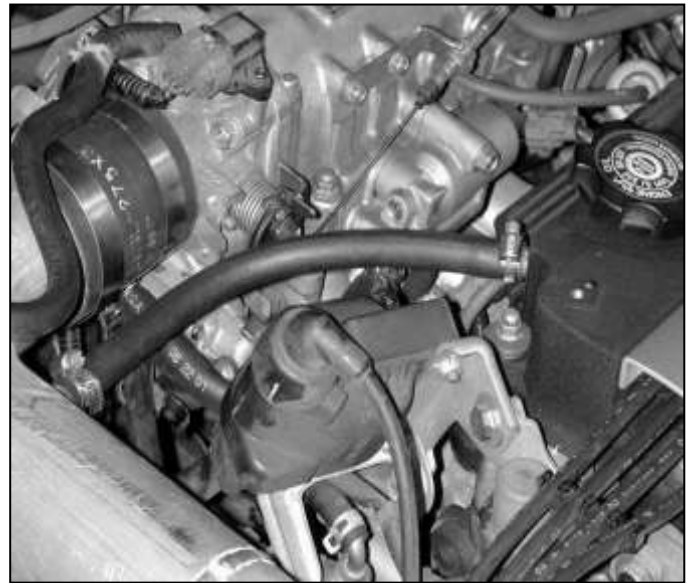

f. For this step the battery must be removed. This can be done by disconnecting the positive terminal and removing the battery tie-down. Once removed, install the AEM® intake pipe into the 2.75" hose on the throttle body. Slide the inlet pipe support over the rubber mount. Use the supplied washer and lock nut and assemble as shown. Reinstall the battery and components.

g. Install the supplied 3/8" breather hose from the nipple on the intake pipe to the nipple on the valve cover. Use the supplied 3/4" hose clamps on the AEM® intake pipe nipple and on the valve cover nipple. Install the small rubber vacuum line plug on the manifold where the vacuum line from the IAC solenoid valve was removed.

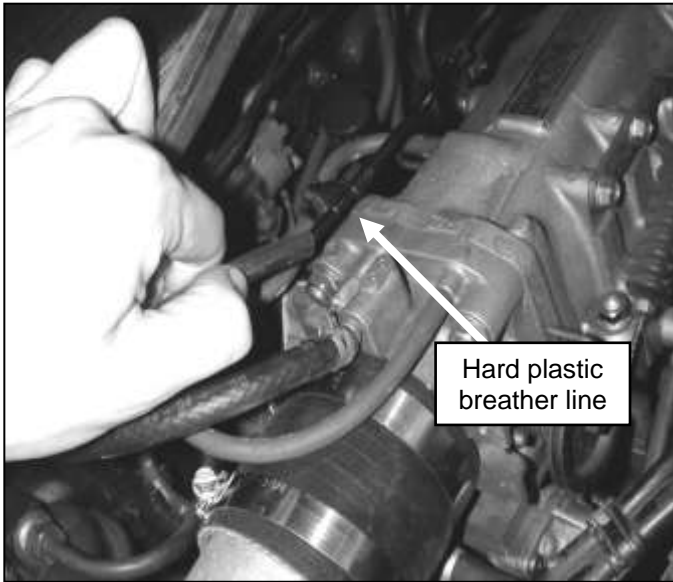

Hard plastic breather line



i. Next install the AEM[®] filter on to the end of the inlet tube. Push the air filter over the inlet pipe until it mates to the step inside the air filter inlet. Install the supplied #64 hose clamp to secure the filter onto the inlet pipe. Tighten the hose clamp after this is done.

h. Remove the original 5/32" breather line that was between the stock intake pipe and the hard plastic breather line. Install the supplied longer 5/32" vacuum hose and attach it to the nipple on the backside of the intake pipe.



j. Check that the air filter is not touching any part of the vehicle. Position the inlet pipe for best fitment. Be sure that the pipe or any other component is not in contact with any part of the vehicle. Tighten the hose clamps at the throttle body. Tighten the nut on the rubber mount. Check for proper hood clearance. Readjust pipe if necessary.

5. Reassemble Vehicle

- a. Replace any coolant recovered during the hose removal by replenishing the recovery tank.
- b. Position the inlet pipes for the best fitment. Be sure that the pipes or any other components do not contact any part of the vehicle. Tighten the rubber mount, all bolts, and hose clamps.
- c. Check for proper hood clearance. Re-adjust pipes if necessary and re-tighten them.
- d. Inspect the engine bay for any loose tools and check that all fasteners that were moved or removed are properly tightened.
- e. Reconnect negative battery terminals and start engine. Let the vehicle idle for 3 minutes. Perform a final inspection before driving the vehicle.

6. CARB Sticker Placement

- a. The C.A.R.B. exemption sticker, (attached), must be visible under the hood so that an emissions inspector can see it when the vehicle is required to be tested for emissions. California requires testing every two years, other states may vary.

7. Service and Maintenance

- a. It is recommended that you service your AEM® Dryflow™ filter every 20,000 miles for optimum performance. Use AEM Dryflow cleaning kit part # 21-110.
- b. Use aluminum polish to clean your polished AEM® intake tube.
- c. Use window cleaner to clean your powder coated AEM® intake tube. **(NOTE: DO NOT USE aluminum polish on powder coated AEM intake tubes)**