



Equipped with AEM® *Dryflow™* Filter
No Oil Required!

INSTALLATION INSTRUCTIONS

PART NUMBER:21-8403

2005-2011 TOYOTA Tacoma V6-4.0L

PARTS LIST

Description	Qty.	Part Number
A	1	21-2049DK
B	1	20-8403
C	2	9456
D	1	2-84032
E	1	5-582
F	3	9448
G	1	2-84031
H	1	5-302
I	1	8-3020
J	1	8-4023
K	1	2-784
L	1	1-2065
M	1	1-3028
N	1	32-3049
O	2	1-2023
P	1	5-3020
Q	2	444.460.08
R	2	559960
S	1	1228560

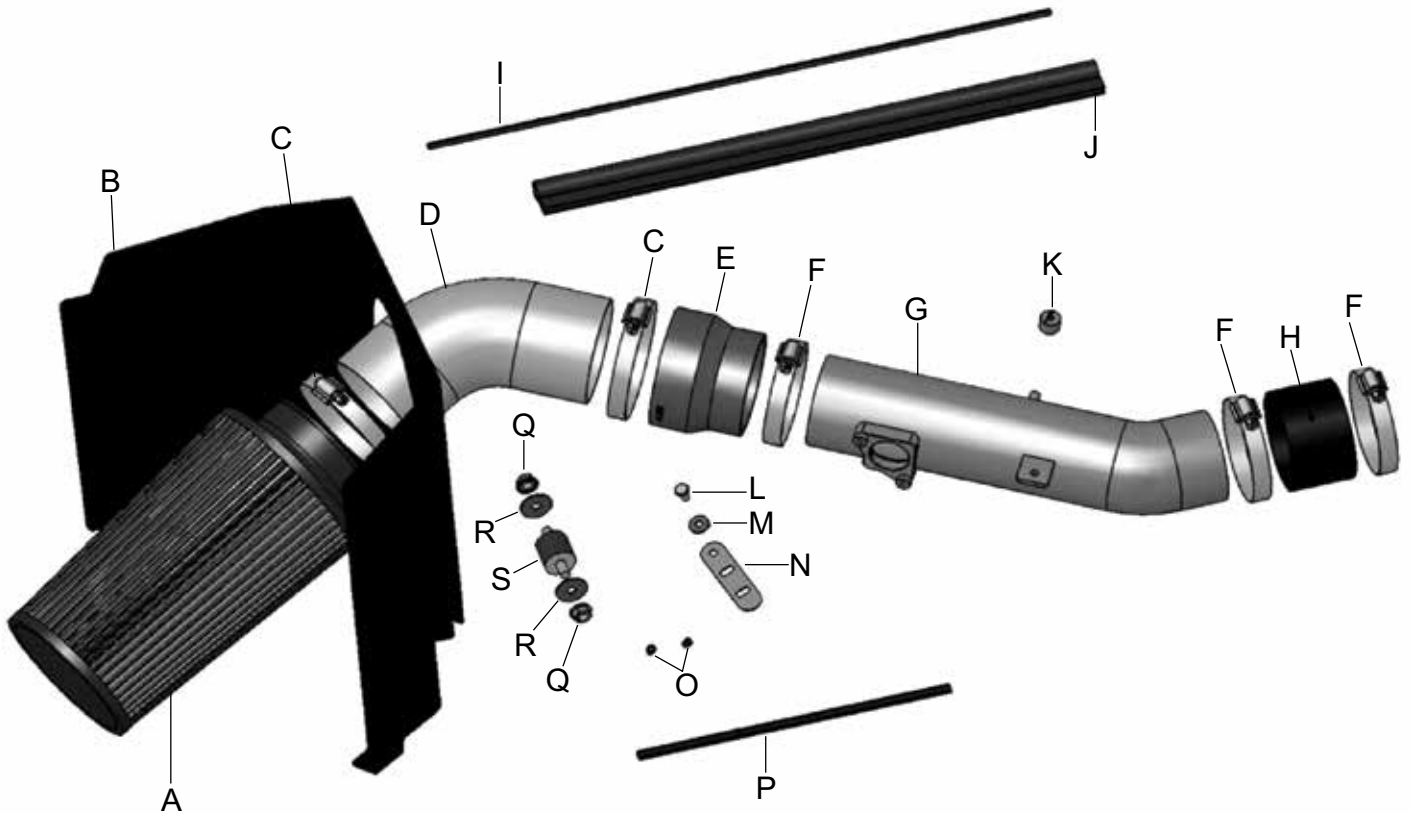

Read and understand these instructions **BEFORE** attempting to install this product. Failure to follow installation instructions and not using the provided hardware may damage the intake tube, throttle body and engine.

1. Preparing Vehicle

- a. Make sure vehicle is parked on level surface.
- b. Set parking brake.
- c. If engine has run in the past two hours, let it cool down.
- d. Disconnect negative battery terminal.
- e. Do not discard stock components after removal of the factory system.

2. Removal of stock system



a. Factory air box system installed.



b. Remove the two nuts securing the engine cover.



c. Disconnect the wire harness connector from the mass air flow (MAF) sensor.



d. Disconnect the breather hose from the air box system.



e. Disconnect the breather hose located in the back of the factory intake system; it is the hose connected to the fuel pressure regulator.



f. Remove the bolt securing the factory intake system to the intake manifold.



g. Remove the bolt securing the factory air box to the valve cover. Retain this bolt, it will be reused in a later step. Remove the zip ties securing the wire harness to the air box.



h. Remove the two bolts that secure the intake tube to the fender well. The bolt closest to the front of the vehicle will be reused in a later step.



i. Remove the bolt securing the bracket for the A/C line. Retain this bolt as it will be reused in a later step.



j. Loosen the hose clamp securing the factory air box to the throttle body.



k. Factory air box system removed from the vehicle.

3. Installation of AEM® intake system.

a. When installing the intake system, do not completely tighten the hose clamps or mounting hardware until instructed to do so.

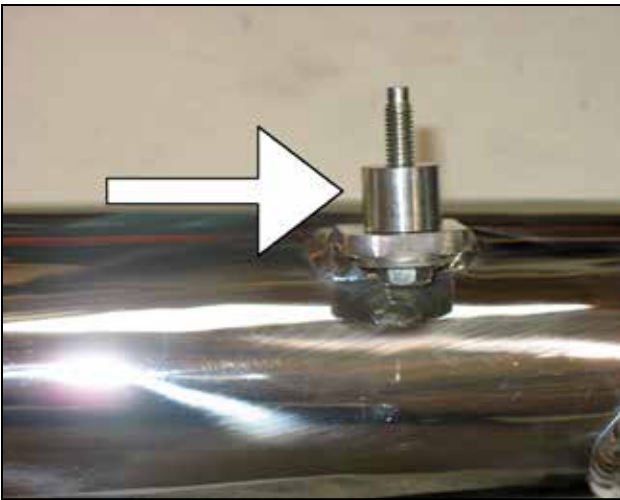

b. Thread the factory bolt removed in step 2g. into the threaded bung on the intake pipe.



c. Install the MAF sensor in the upper intake pipe using the supplied bolts.



d. Loosen the two nuts securing the ABS module. Tilt the ABS module slightly and slide the heat shield under the ABS bracket.



e. Align the heat shield mounting holes with the bolt holes that were exposed during steps 2h and 2i when the bolts were removed. Use the factory bolts to secure the heat shield in place. Install the edge trim, and the rubber edge trim onto the heat shield. Install the supplied rubber mount onto the heat shield using the provided hardware.



f. Attach the supplied bracket with an M6 bolt and washer.



g. Attach the factory zip ties to the bracket installed in step 3f.



h. Install the silicone coupler to the throttle body using the supplied #48 hose clamp.



i. Insert the upper intake pipe into the silicone coupler and loosely secure using the another #48 hose clamp.



j. Align the bolt installed in step 3b. with the engine cover. Once aligned, remove the engine cover again.



k. Install the screened hose adapter onto the end of the intake pipe. Insert the short intake pipe into the hose adapter and align the pipe's bracket with the rubber mount. Loosely secure the hose adapter and short intake pipe with the provided #56 & #48 hose clamps.



l. Install the 5/32 ID hose onto the fuel pressure regulator.



m. Attach the open end of the 5/32 ID hose onto the intake pipe's nipple.



n. Plug the MAF sensor wiring harness into the MAF sensor.



o. Install the PCV hose on the upper intake pipe on the nipple located near the front of the vehicle. Use the factory hose clamp to secure.

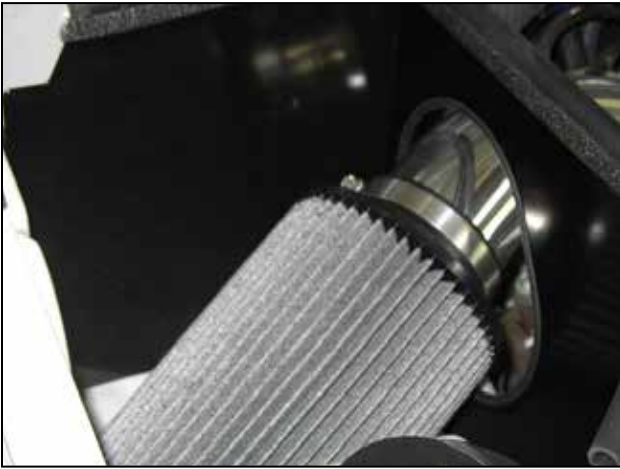

p. Insert the air filter into the heat shield cavity and attach the air filter to the intake pipe. Position the air filter for best fitment and secure to the intake pipe with a #56 hose clamp. Secure the intake pipe's bracket to the rubber mount with the supplied washer and locknut.

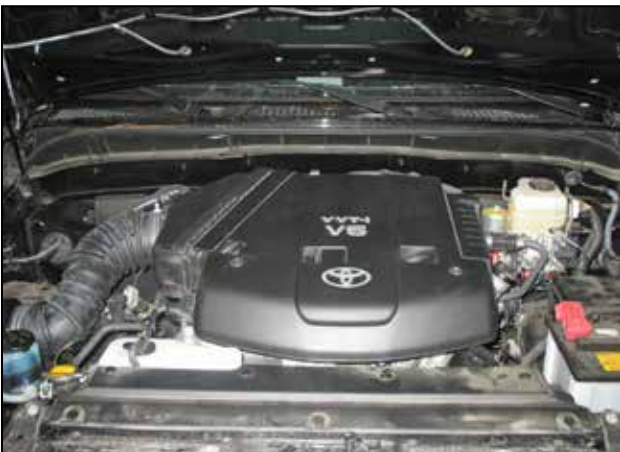

Factory intake system installed



AEM® intake system installed

4. Reassemble Vehicle

- a. Position the inlet pipes for the best fitment. Be sure that the pipes or any other components do not contact any part of the vehicle. Tighten the rubber mount, all bolts, and hose clamps.
- b. Check for proper hood clearance. Re-adjust pipes if necessary and re-tighten them.
- c. Inspect the engine bay for any loose tools and check that all fasteners that were moved or removed are properly tightened.
- d. Reconnect negative battery terminals and start engine. Let the vehicle idle for 3 minutes. Perform a final inspection before driving the vehicle.

5. Service and Maintenance

- a. AEM Induction Systems requires cleaning the intake system's air filter element every 100,000 miles. When used in dusty or off-road environments, our filters will require cleaning more often. We recommend that you visually inspect your filter once every 25,000 miles to determine if the screen is still visible. When the screen is no longer visible some place on the filter element, it is time to clean it. To clean, purchase our Synthetic air filter cleaner, part number 99-0624 and follow the easy instructions.
- b. Use window cleaner to clean your powder coated AEM® intake tube.

NOTE: DO NOT USE aluminum polish on powder coated AEM® intake tubes.