



Equipped with AEM® Dryflow™ Filter
No Oil Required!

INSTALLATION INSTRUCTIONS

PART NUMBER: 21-8213

| | | | | |
|-----------|----------|---------|---------|-------------------------|
| 2005-2010 | CHRYSLER | 300 | V6-3.5L | C.A.R.B. E.O. # D-670-6 |
| 2006-2008 | DODGE | Charger | V6-3.5L | C.A.R.B. E.O. # D-670-6 |
| 2005-2008 | DODGE | Magnum | V6-3.5L | C.A.R.B. E.O. # D-670-6 |

PARTS LIST

| Description | Qty. | Part Number |
|-------------|------|-------------|
| A | 1 | 21-203DK |
| B | 1 | 9452 |
| C | 1 | 8-149 |
| D | 1 | 20-8213 |
| E | 1 | 8-3013 |
| F | 1 | 2-82131 |
| G | 1 | 08407 |
| H | 2 | 9448 |
| I | 1 | 5-302 |
| J | 1 | 784634 |
| K | 1 | 8-4009 |
| L | 1 | 1228560 |
| M | 2 | 559960 |
| N | 2 | 444.460.08 |

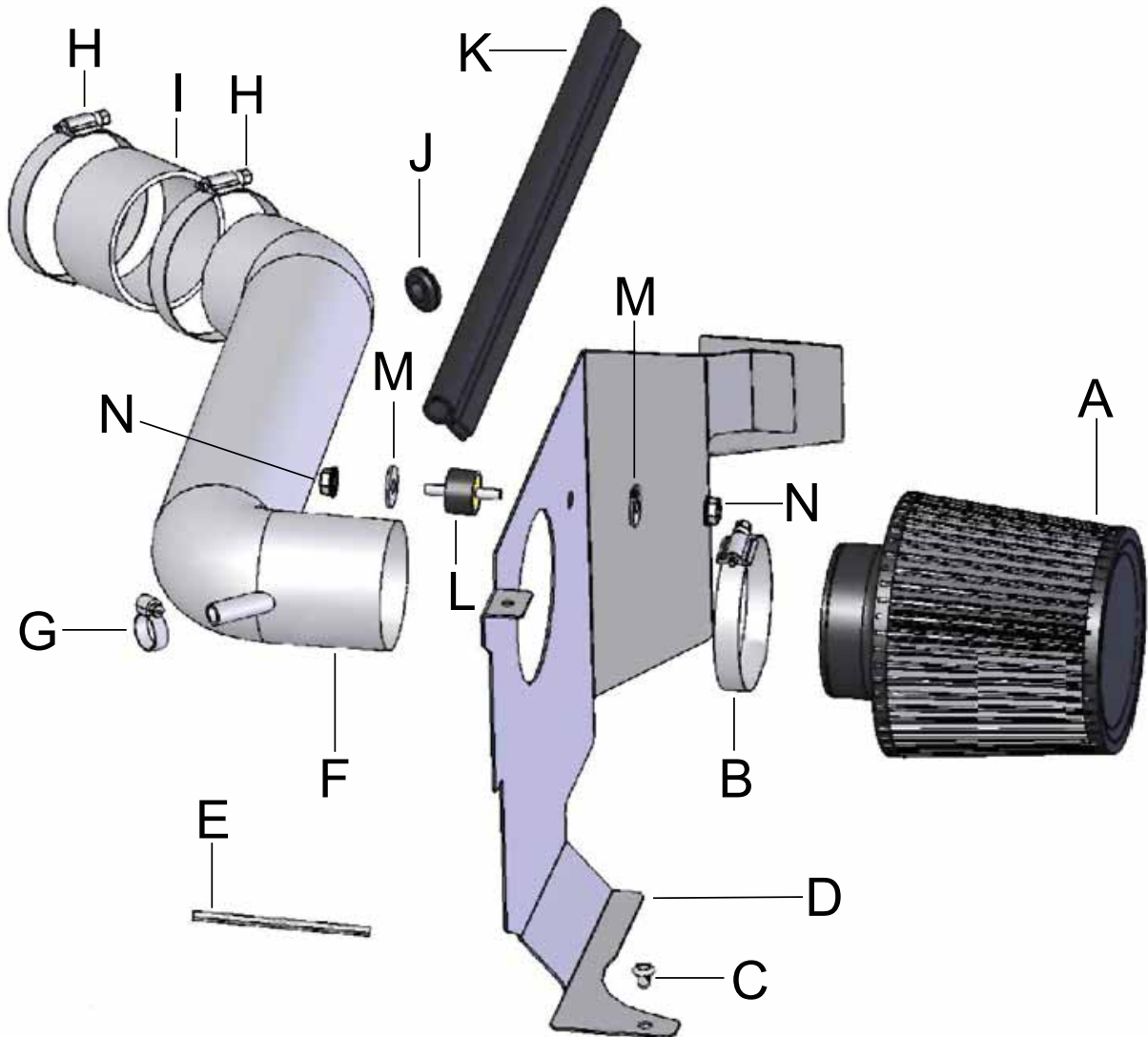

Read and understand these instructions **BEFORE** attempting to install this product. Failure to follow installation instructions and not using the provided hardware may damage the intake tube, throttle body and engine.

1. Preparing Vehicle

- a. Make sure vehicle is parked on level surface.
- b. Set parking brake.
- c. If engine has run in the past two hours, let it cool down.
- d. Disconnect the negative battery terminal.
- e. Do not discard stock components after removal of the factory system.

2. Removal of stock system



a. Disconnect the inlet air temperature (IAT) sensor connector.

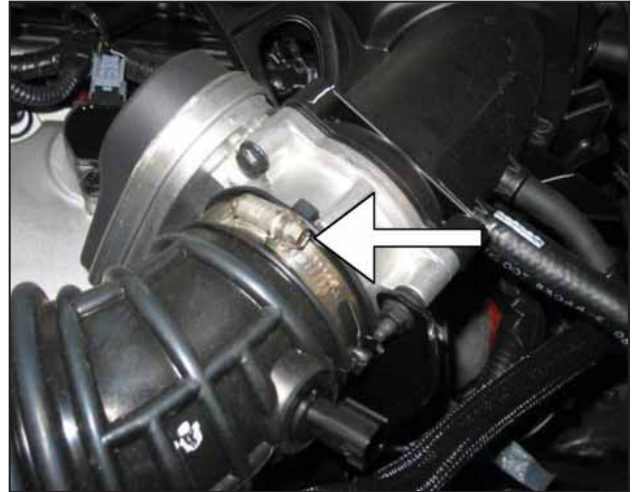

b. Loosen hose clamp at the throttle body.



c. Remove the PCV breather tube from the air box.



d. Loosen and remove the air box mounting screw. This screw will be reused.



e. Remove the coolant line from the air tube.



f. Remove the air box assembly from the engine bay.

3. Installation of AEM® intake system.

- a. When installing the intake system, do not completely tighten the hose clamps or mounting hardware until instructed to do so.

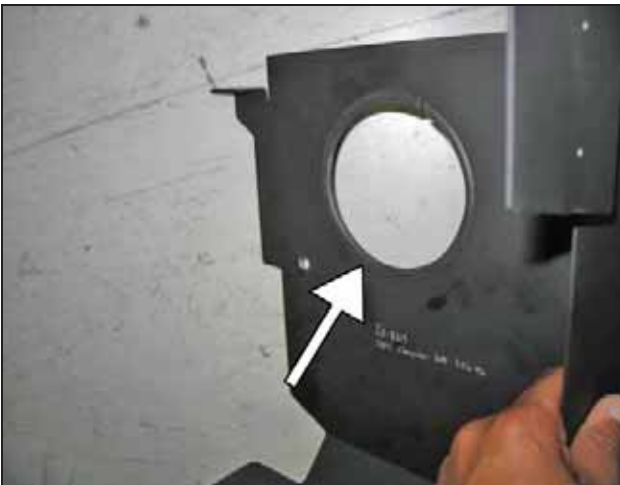

b. Attach the rubber edge trim to the intake pipe opening on the heat shield.



c. Attach the foam gasket onto the top of the heat shield.



d. Insert the heat shield as shown. The vertical tab slides into the coolant reservoir. The bottom tab slides underneath the coolant and vacuum lines.



e. Insert the push-in clip on the heat shield base.

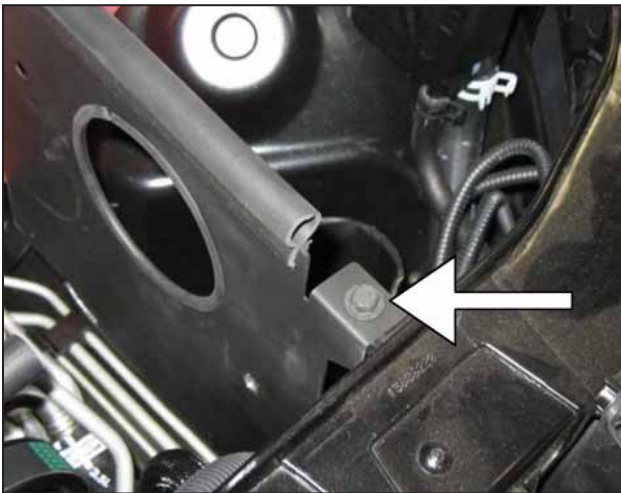

f. Secure the remaining tab with the factory screw.



g. Insert the rubber mount as shown.



h. Secure the rubber mount with the M8 washer and nut.



i. Insert the intake pipe as shown. Align the intake pipe bracket with the rubber mount.



j. Once the bracket is aligned, check the intake pipe for clearance around the rubber edge trim. Secure the bracket with a M8 washer and nut.



k. Reattach the PCV breather hose to the breather nipple on the intake pipe. Secure with a hose clamp.



l. Attach the AEM® Dryflow™ air filter. Check for clearance around the rubber edge trim and secure.



m. Insert the grommet for the IAT sensor into the intake pipe. Insert the IAT sensor and reattach the IAT sensor harness connector that was disconnected in step 2a. Secure the intake pipe to the throttle body coupler.



AEM® intake system installed

4. Reassemble Vehicle

- a. Position the inlet pipes for the best fitment. Be sure that the pipes or any other components do not contact any part of the vehicle. Tighten the rubber mount, all bolts, and hose clamps.
- b. Check for proper hood clearance. Re-adjust pipes if necessary and re-tighten them.
- c. Inspect the engine bay for any loose tools and check that all fasteners that were moved or removed are properly tightened.
- d. Reconnect negative battery terminal and start engine. Let the vehicle idle for 3 minutes. Perform a final inspection before driving the vehicle.

5. CARB Sticker Placement

- a. The C.A.R.B. exemption sticker, (attached), must be visible under the hood so that an emissions inspector can see it when the vehicle is required to be tested for emissions. California requires testing every two years, other states may vary.

6. Service and Maintenance

- a. AEM Induction Systems requires cleaning the intake system's air filter element every 100,000 miles. When used in dusty or off-road environments, our filters will require cleaning more often. We recommend that you visually inspect your filter once every 25,000 miles to determine if the screen is still visible. When the screen is no longer visible some place on the filter element, it is time to clean it. To clean, purchase our Synthetic air filter cleaner, part number 99-0624 and follow the easy instructions.
- b. Use window cleaner to clean your powder coated AEM® intake tube.

NOTE: DO NOT USE aluminum polish on powder coated AEM® intake tubes.