



INSTALLATION INSTRUCTIONS

PART NUMBER: 21-8027

2008-2009 PONTIAC G8 V8-6.0L C.A.R.B. E.O. # D-670-2

PARTS LIST

Description	Qty.	Part Number
A Inlet Tube	1	2-80271
B Elbow, 4.00/3.75 X 11.5 Deg.	2	5-439
C Hose; 3/8"ID X 13"L	1	5-1013
D 1/2" Bnd. Hose Clamp, 3.56"-4.50"	4	9464
E Hose Clamp, 3/4"	2	4093-5

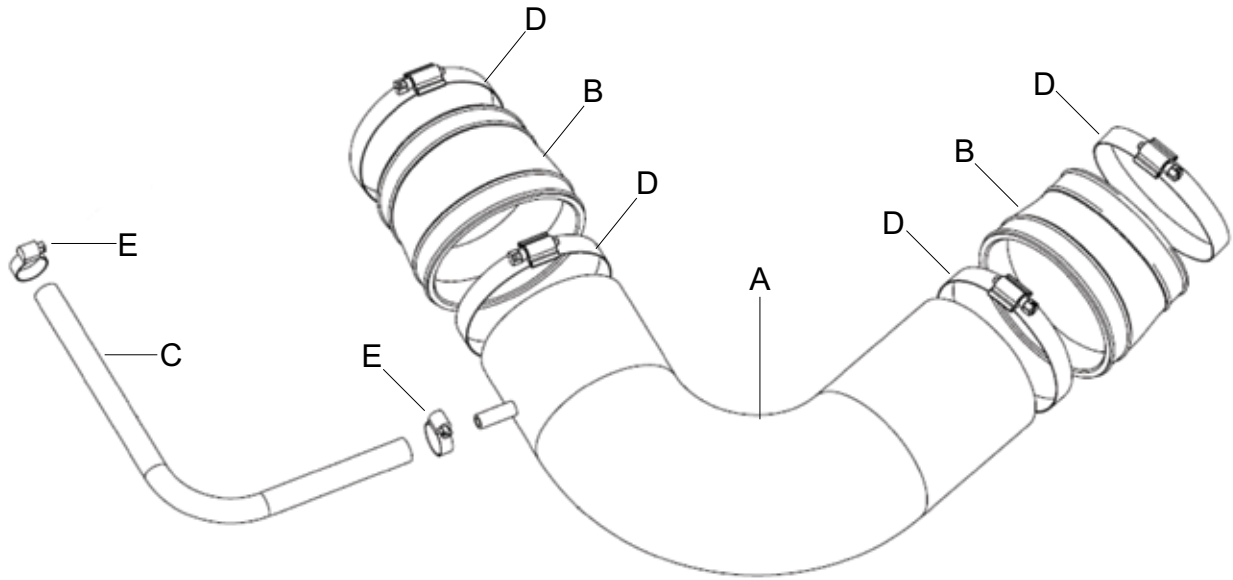

Read and understand these instructions **BEFORE** attempting to install this product. Failure to follow installation instructions and not using the provided hardware may damage the intake tube, throttle body and engine.

1. Preparing Vehicle

- a. Make sure vehicle is parked on level surface.
- b. Set parking brake.
- c. If engine has run in the past two hours, let it cool down.
- d. Disconnect negative battery terminal.
- e. Do not discard stock components after removal of the factory system.

2. Removal of stock system



a. Factory air box system installed.



b. Unclip breather hose from resonator chamber



c. Remove engine cover (lift up and pull forward). Loosen hose clamps on the inlet tube at the throttle body and MAF body. Also disconnect and remove the breather hose from the valve cover.



d. Remove the inlet tube.

3. Installation of AEM® intake system.

a. When installing the intake system, do not completely tighten the hose clamps or mounting hardware until instructed to do so.



b. On the inlet pipe install the 5-439 elbow and breather hose. Loosely place clamps on couplers and breather hose.



c. Slide coupler over MAF body, then the elbow over the throttle body, align inlet and secure the hose clamps.



d. Route the breather hose around pulley and under AC lines.



e. Secure the breather hose to the valve cover and re-install the engine cover.



Factory air box system



AEM® intake system installed

4. Reassemble Vehicle

- Position the inlet pipes for the best fitment. Be sure that the pipes or any other components do not contact any part of the vehicle. Tighten the rubber mount, all bolts, and hose clamps.
- Check for proper hood clearance. Re-adjust pipes if necessary and re-tighten them.
- Inspect the engine bay for any loose tools and check that all fasteners that were moved or removed are properly tightened.
- Reconnect negative battery terminals and start engine. Let the vehicle idle for 3 minutes. Perform a final inspection before driving the vehicle.

5. CARB Sticker Placement

- The C.A.R.B. exemption sticker, (attached), must be visible under the hood so that an emissions inspector can see it when the vehicle is required to be tested for emissions. California requires testing every two years, other states may vary.
- Most General Motors vehicles (including Chevrolet) have the Vehicle Emissions Certification Information (VECI) label affixed to the air filter box. In order to be compliant with California emissions laws, the label **MUST** remain in the engine compartment. If the Vehicle Emission Control Information label is removed during modification, a new replacement label must be obtained and installed in a readily visible position in the engine compartment. The label shall not be affixed to any equipment which is easily detached from the vehicle. We recommend that the label is affixed to the underside of the hood adjacent to the hood latch. The label is Vehicle Identification Number dependent and can be ordered from the vehicle dealership. In order to receive the proper decal please bring your VIN with you. Failure to have the VECI under the hood may result in failure of a pre-registration smog test.

6. Service and Maintenance

- It is recommended that you service your AEM® Dryflow™ filter every 20,000 miles for optimum performance. Use AEM Dryflow cleaning kit part # 21-110.
- Use aluminum polish to clean your polished AEM® intake tube.
- Use window cleaner to clean your powder coated AEM® intake tube. **(NOTE: DO NOT USE aluminum polish on powder coated AEM intake tubes).**