



Equipped with AEM® Dryflow™ Filter  
No Oil Required!

## INSTALLATION INSTRUCTIONS

### PART NUMBER: 21-8023

2007-08	CADILLAC	Escalade	V8-6.2L	Exc. Mechanical Fan	C.A.R.B. E.O. # D-670-2
2007-08	CHEVROLET	Avalanche	V8-5.3L	Exc. Mechanical Fan	C.A.R.B. E.O. # D-670-2
2008	CHEVROLET	Avalanche	V8-6.0L	Exc. Mechanical Fan	C.A.R.B. E.O. # D-670-2
2007	CHEVROLET	Avalanche	V8-6.0L	Exc. Mechanical Fan	SEE * NOTE
2007-09	CHEVROLET	Cheyenne	V8-5.3L	Exc. Mechanical Fan	SEE * NOTE
2007-08	CHEVROLET	Silverado 1500	V8-4.8L, 5.3L, 6.0L	Exc. Mechanical Fan	C.A.R.B. E.O. # D-670-2
2007	CHEVROLET	Silverado 2500 HD	V8-6.0L		SEE * NOTE
2007	CHEVROLET	Silverado 3500 HD	V8-6.0L		SEE * NOTE
2007-08	CHEVROLET	Suburban 1500	V8-5.3L, 6.0L	Exc. Mechanical Fan	C.A.R.B. E.O. # D-670-2
2008	CHEVROLET	Suburban 2500	V8-6.0L	Exc. Mechanical Fan	SEE *NOTE
2007	CHEVROLET	Suburban 2500	V8-6.0L	Exc. Mechanical Fan	C.A.R.B. E.O. # D-670-2
2008	CHEVROLET	Tahoe	V8-5.3L	Exc. Mechanical Fan	C.A.R.B. E.O. # D-670-2
2008	CHEVROLET	Tahoe	V8-4.8L	Exc. Mechanical Fan	SEE * NOTE
2007	CHEVROLET	Tahoe	V8-4.8L, 5.3L	Exc. Mechanical Fan	C.A.R.B. E.O. # D-670-2
2008	GMC	Sierra 1500	V8-5.3L, 6.0L		C.A.R.B. E.O. # D-670-2
2008	GMC	Sierra 1500	V8-4.8L	Exc. Mechanical Fan	SEE * NOTE
2007	GMC	Sierra 1500	V8-6.0L, 5.3L, 4.8L	Exc. Mechanical Fan	C.A.R.B. E.O. # D-670-2
2007	GMC	Sierra 2500 HD	V8-6.0L		SEE * NOTE
2007	GMC	Sierra 3500 HD	V8-6.0L		SEE * NOTE
2008	GMC	Sierra Denali	V8-6.2L		C.A.R.B. E.O. # D-670-2
2007	GMC	Sierra Denali	V8-6.2L	Exc. Mechanical Fan	SEE * NOTE
2008	GMC	Yukon	V8-4.8L, 5.3L		C.A.R.B. E.O. # D-670-2
2007	GMC	Yukon	V8-4.8L, 5.3L	Exc. Mechanical Fan	C.A.R.B. E.O. # D-670-2
2008	GMC	Yukon Denali	V8-6.2L		C.A.R.B. E.O. # D-670-2
2007	GMC	Yukon Denali	V8-6.2L	Exc. Mechanical Fan	C.A.R.B. E.O. # D-670-2
2007-08	GMC	Yukon Denali XL	V8-6.2L	Exc. Mechanical Fan	SEE * NOTE
2008	GMC	Yukon XL 1500	V8-6.2L, 6.0L, 5.3L		C.A.R.B. E.O. # D-670-2
2007	GMC	Yukon XL 1500	V8-6.2L, 6.0L, 5.3L	Exc. Mechanical Fan	C.A.R.B. E.O. # D-670-2
2008	GMC	Yukon XL 2500	V8-6.0L		C.A.R.B. E.O. # D-670-2
2007	GMC	Yukon XL 2500	V8-6.0L	Exc. Mechanical Fan	C.A.R.B. E.O. # D-670-2

## PARTS LIST

Description	Qty.	Part Number
A	1	21-2099DK
B	1	20-8026
C	1	8-4013
D	1	8-4012
E	1	5-350
F	1	5-435
G	1	9-7000N
H	1	5-1016
I	1	1228560
J	1	102504
K	1	1-127
L	2	559960
M	2	444.460.08
N	1	94104
O	3	9456
P	1	9464
Q	2	4093-5
R	1	2-80231

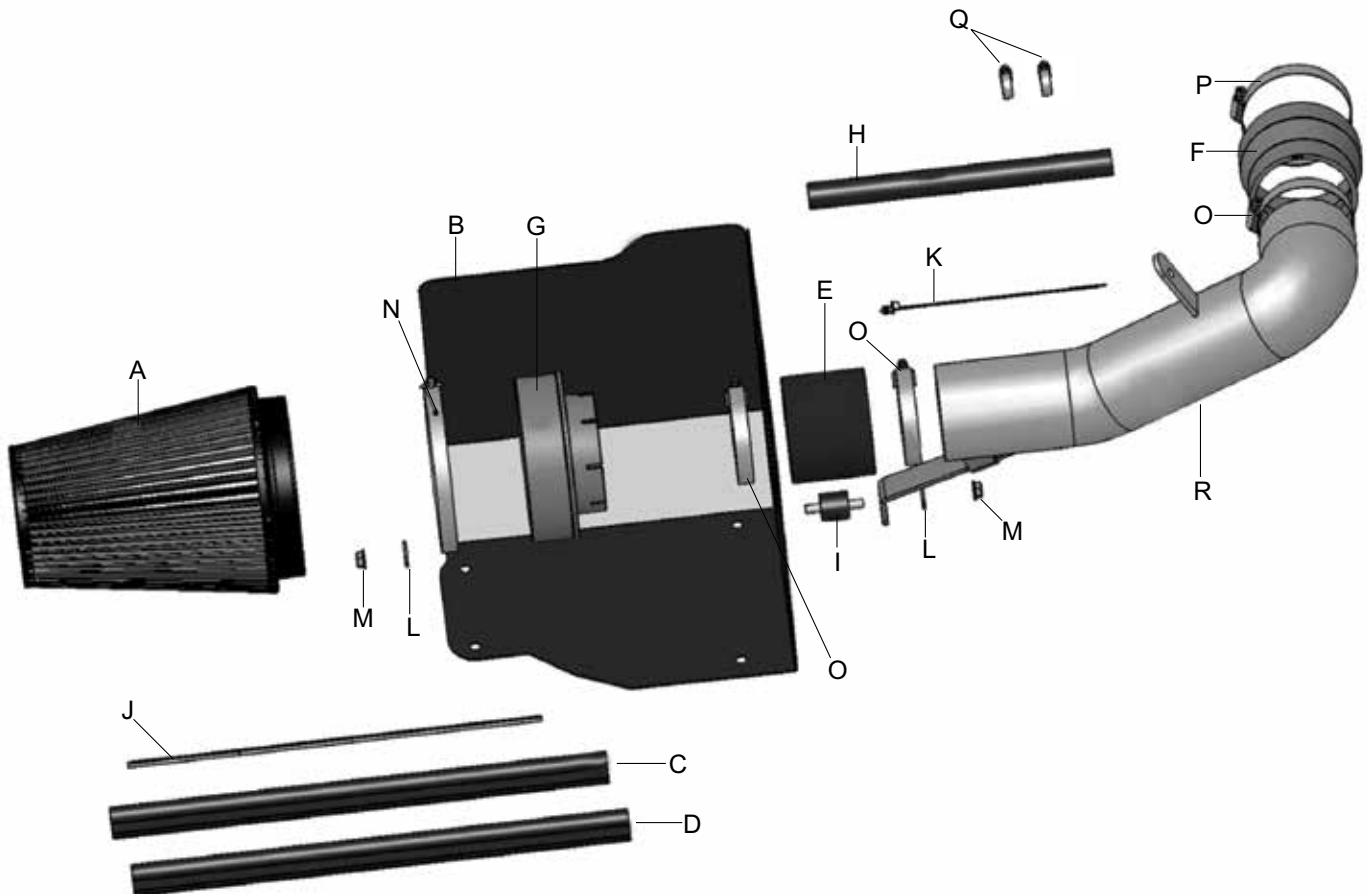

Read and understand these instructions **BEFORE** attempting to install this product. Failure to follow installation instructions and not using the provided hardware may damage the intake tube, throttle body and engine.

## 1. Preparing Vehicle

- a. Make sure vehicle is parked on level surface.
- b. Set parking brake.
- c. If engine has run in the past two hours, let it cool down.
- d. Disconnect negative battery terminal.
- e. Do not discard stock components after removal of the factory system.

## 2. Removal of stock system



a. Stock airbox system. Pull engine cover off.



b. Pull out the breather hose out of the resonating chamber in the stock intake system.



c. Loosen the hose clamp located at the throttle body.



d. Pull the plastic radiator hose tree mount out of the stock intake tube holder.





e. Disconnect the mass air flow sensor wire, and loosen the hose clamp securing the MAF housing to the stock inlet tube.



f. Pull the stock inlet tube out of the vehicle.



g. Pull the stock air filter housing straight up out of the vehicle.



h. Remove the four bolts securing the stock airbox mounting plate.



i. Remove the breather hose from the valve cover.

### 3. Installation of AEM® intake system.

- a. When installing the intake system, do not completely tighten the hose clamps or mounting hardware until instructed to do so.
- b. Before installing intake pipe be sure to check for packaging material in the intake pipe.



c. Install the heat shield using the four stock bolts used to secure the air filter box mounting plate.



d. Install rubber mount on the heat shield using the supplied washer and nut.



e. Install the reducing coupler on the throttle body, and loosely put the supplied hose clamps on the two ends of the coupler.



f. Install the reinforced silicone coupler on the MAF housing. Do not put the hose clamps on before attempting to do this.





g. Insert intake pipe into reducing coupler located at the throttle body. Route the intake pipe under the upper radiator hose. Secure the bracket to the rubber mount on the heat shield.



h. Then attach the assembly made in step 3f to the end of the intake pipe. Then reconnect the MAF sensor wire.



i. Use the stock plastic radiator clamp to secure the radiator hose away from the intake pipe. By inserting it into the bracket located on the pipe.



j. Use the supplied tree mount to secure the MAF sensor wire to heat shield.



k. Create an assembly of the supplied air horn and the air filter.

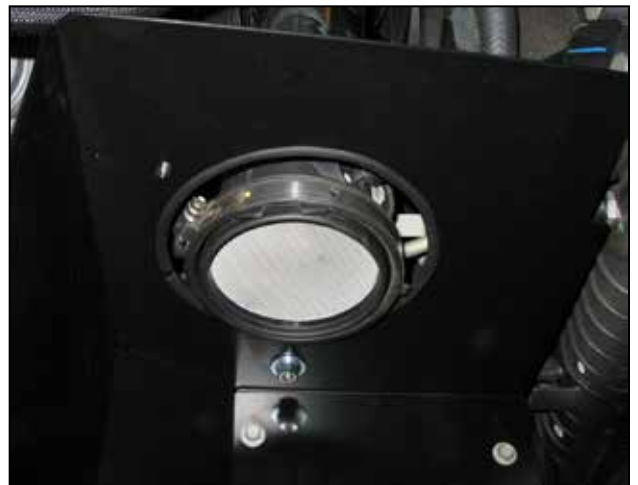

l. Install rubber edge trim on the heat shield where the intake pipe will pass through.



m. Install filter assembly into the stock MAF rubber coupler. Also put the rubber edge gasket along the top edge of the heat shield.



n. Secure the supplied breather hose with the supplied hose clamp.



o. Finally, secure the breather hose to the nipple on the intake pipe.



Factory airbox system installed



AEM® intake system installed

#### 4. Reassemble Vehicle

- a. Position the inlet pipes for the best fitment. Be sure that the pipes or any other components do not contact any part of the vehicle. Tighten the rubber mount, all bolts, and hose clamps.
- b. Check for proper hood clearance. Re-adjust pipes if necessary and re-tighten them.
- c. Inspect the engine bay for any loose tools and check that all fasteners that were moved or removed are properly tightened.
- d. Reconnect negative battery terminals and start engine. Let the vehicle idle for 3 minutes. Perform a final inspection before driving the vehicle.

#### 5. CARB Sticker Placement

- a. The C.A.R.B. exemption sticker, (attached), must be visible under the hood so that an emissions inspector can see it when the vehicle is required to be tested for emissions. California requires testing every two years, other states may vary.
- b. Most General Motors trucks (including Chevrolet) have the Vehicle Emissions Certification Information (VECI) label affixed to the air filter box. In order to be compliant with California emissions laws, the label **MUST** remain in the engine compartment. If the Vehicle Emission Control Information label is removed during modification, a new replacement label must be obtained and installed in a readily visible position in the engine compartment. The label shall not be affixed to any equipment which is easily detached from the vehicle. We recommend that the label is affixed to the underside of the hood adjacent to the hood latch. The label is Vehicle Identification Number dependent and can be ordered from the vehicle dealership. In order to receive the proper decal please bring your VIN with you. Failure to have the VECI under the hood may result in failure of a pre-registration smog test.

#### 6. Service and Maintenance

- a. It is recommended that you service your AEM® Dryflow™ filter every 20,000 miles for optimum performance. Use AEM Dryflow cleaning kit part # 21-110.
- b. Use aluminum polish to clean your polished AEM® intake tube.
- c. Use window cleaner to clean your powder coated AEM® intake tube. **(NOTE: DO NOT USE aluminum polish on powder coated AEM intake tubes)**