



Equipped with AEM® Dryflow™ Filter
No Oil Required!

INSTALLATION INSTRUCTIONS

PART NUMBER

21-766C (Gun Metal Gray Finish)

2015	CHEVROLET	SPARK	1.2L
2014	CHEVROLET	SPARK	1.2L
2013	CHEVROLET	SPARK	1.2L

Not legal for sale or use on any pollution controlled motor vehicle in California or states adopting California emission procedures.

ITEM NO.	PART NUMBER	DESCRIPTION	QTY.
1	102486	EDGE TRIM, 3/4" TOP LOC., 44"L	1
2	20-8560	HEAT SHIELD, CHEVROLET SPARK 1.2L	1
3	21685	WASHER; 1" X .300 X .100 RUBBER	2
4	9436	1/2' BNDHOSE CLAMP, 1.81"-2.75"	2
5	08476	HOSE; 2-1/2" TO 2-1/4" ID X 2" L	1
6	1-2105	BOLT; SOCKET M4-.7 X 8MM	2
7	444.460.04	NUT; M6 HEX SERRATED	1
8	08160	WASHER; 1"D X 1/4 HOLE FENDER	1
9	1228598	MOUNT, RUBBER 5/8" X 6MM	1
10	2-1545C	TUBE; 2.50"OD X 11", 21-766	1
11	9444	HOSE CLAMP, 2.31-3.25"	1
12	21-201DK	AIR FILTER; 2.5" X 5" DRYFLOW	1

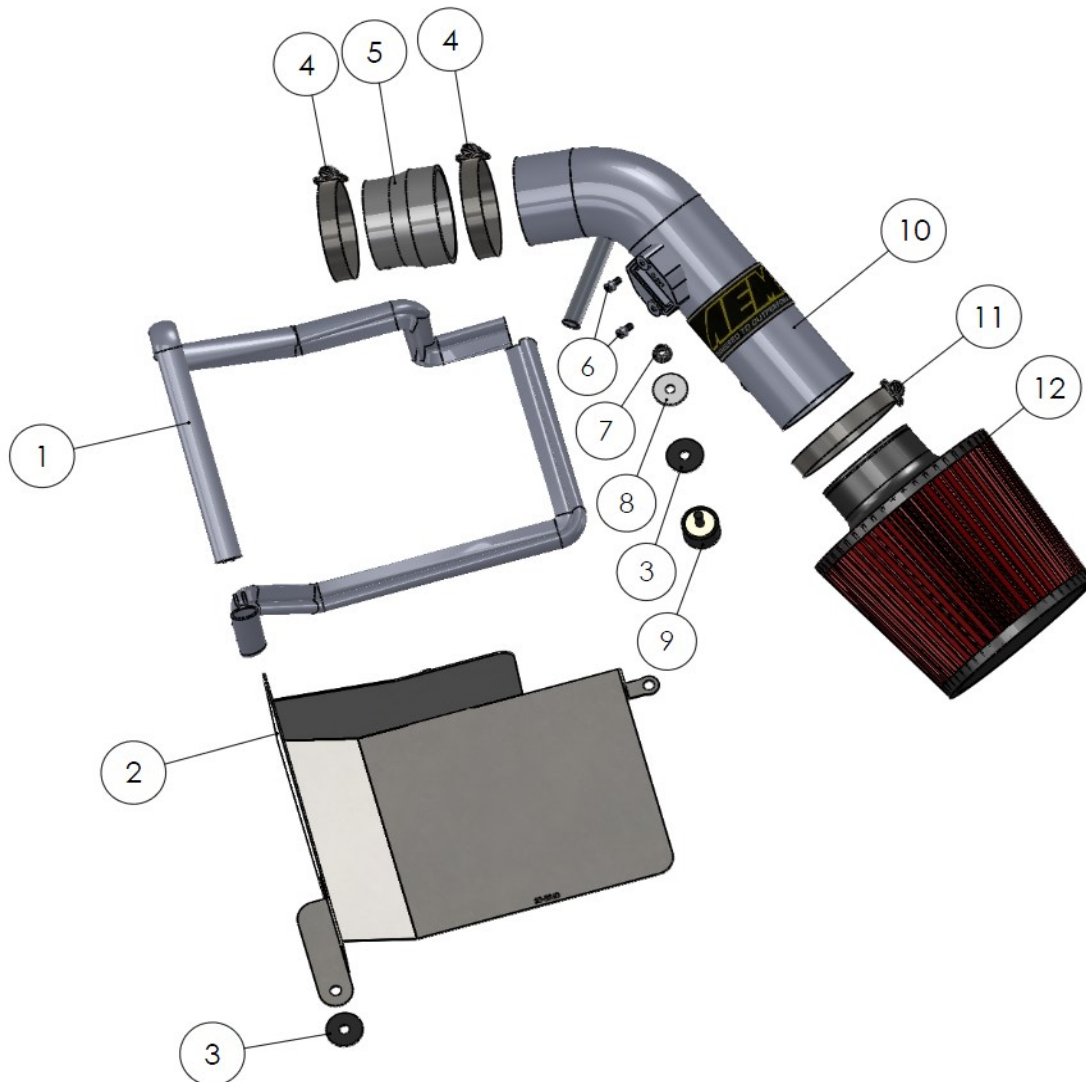

Read and understand these instructions **BEFORE** attempting to install this product. Failure to follow installation instructions and not using the provided hardware may damage the intake tube, throttle body and engine.

1. Preparing Vehicle

- a. Make sure vehicle is parked on level surface.
- b. Set the parking brake.
- c. If engine has run in the past two hours, let it cool down.
- d. Disconnect negative battery terminal.
- e. Do not discard stock components after removal of the factory system.
- f. Open the air intake kit package and make sure all parts are included.

Tools Needed:

FLAT HEAD SCREWDRIVER

PLIERS

10MM & 5.5MM SOCKET

2.5MM ALLEN

6" EXTENSION

SOCKET DRIVER

2. Removal of stock system



a. Disconnect the mass air sensor connector by sliding the gray locking tab and depressing the tab.



b. Loosen the spring clamp and remove the vent tube from the stock intake tube. The spring clamp will be reused in step 3k.



c. Remove the two bolts holding the front of the stock air box to the vehicle. One of these will be reused in step 3f.



d. Remove the single bolt holding the rear of the stock air box to the vehicle.

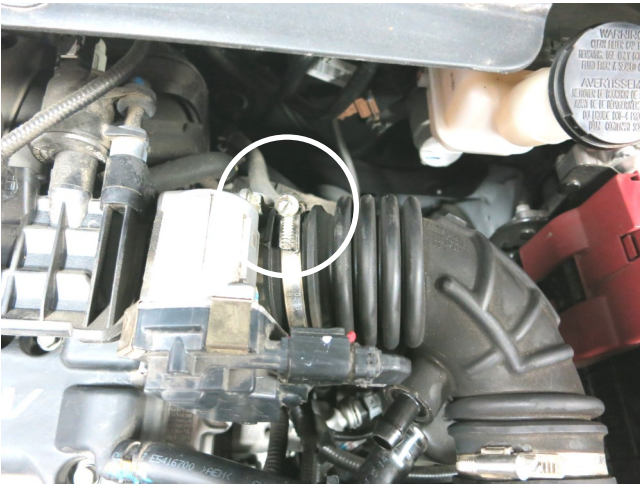

e. Loosen the hose clamp at the throttle body and disconnect the stock intake from the throttle body.

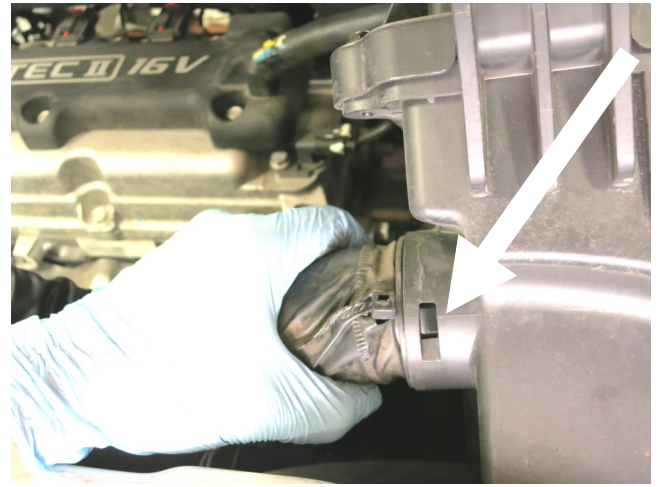

f. Push in the clips on the stock air box to remove the fresh air tube from the lower air box. Then remove the stock intake system from the vehicle.



g. Remove the M6 nut in front of the battery as circled. This nut will be reused in step 3h.

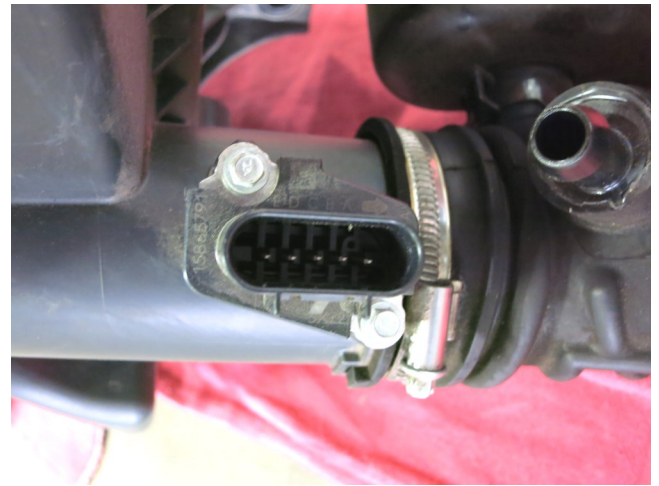

h. Remove the two bolts securing the Mass Air Flow sensor from the stock intake. The sensor will be reinstalled in step 3a. **NOTE: DO NOT DISCARD ANY OF YOUR STOCK EQUIPMENT.**

3. Installation of AEM® intake system.

- a. When installing the intake system, do not completely tighten the hose clamps or mounting hardware until instructed to do so.



a. Install the Mass Air Flow sensor into the AEM intake tube that was removed in step 2h. with the provided hardware.



b. Install the provided edge trim onto the heat shield. Trimming of the edge trim may be necessary.

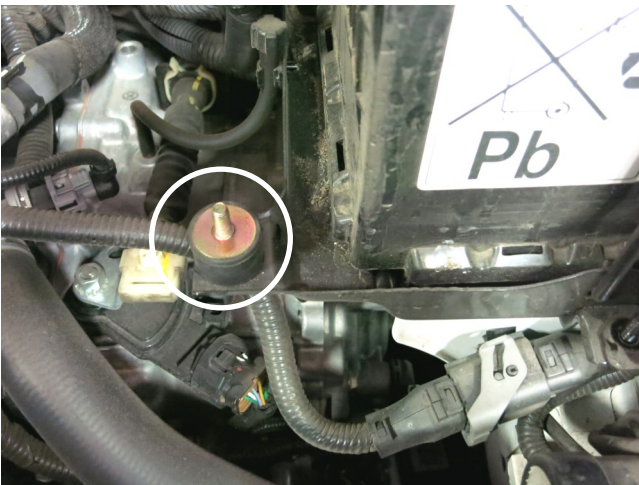

c. Install the provided rubber stud mount into the battery tray as shown.

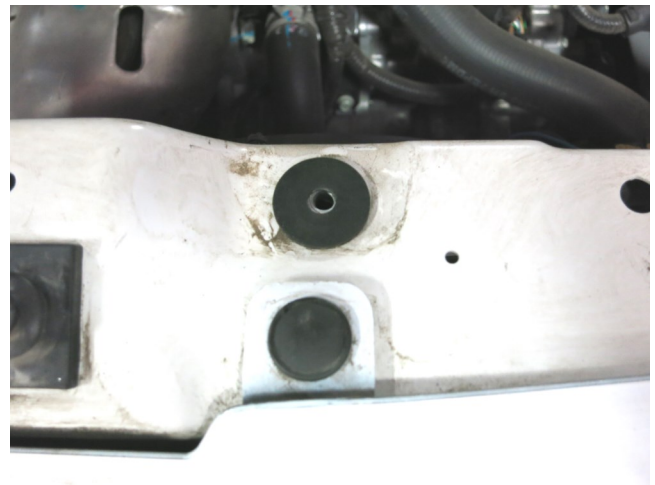

d. Place the provided rubber washer on the front core support over the mounting hole.

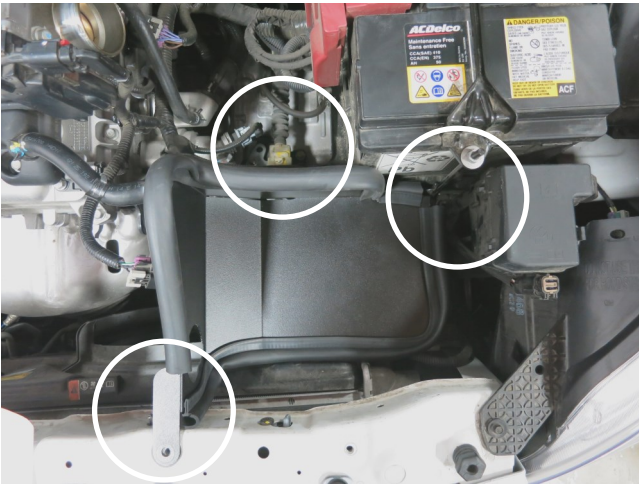

e. Place the heat shield into the vehicle aligning all three mounting locations as shown.

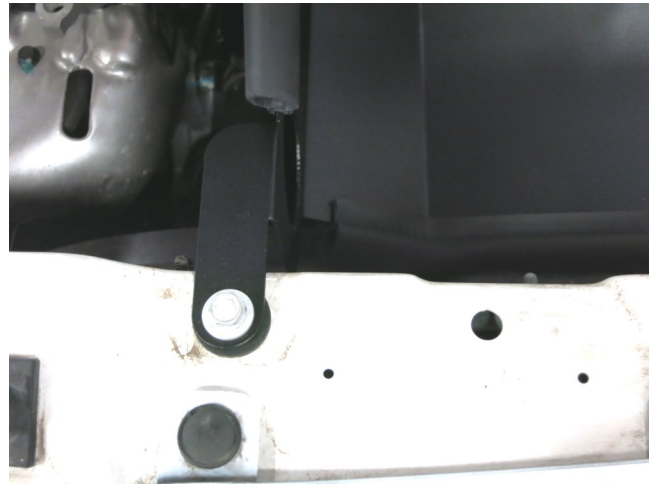

f. Install the bolt into the core support that was removed in step 2c.



g. Align the heat shield with the rubber mounted stud that was previously installed and place the provided rubber washer over the stud.



h. Install the nut that was removed in step 2g. to secure the heat shield in front of the battery tray.



i. Install the provided coupler and hose clamps onto the throttle body. Tighten the hose clamp circled at this time.



j. Install the AEM intake tube into the coupler.

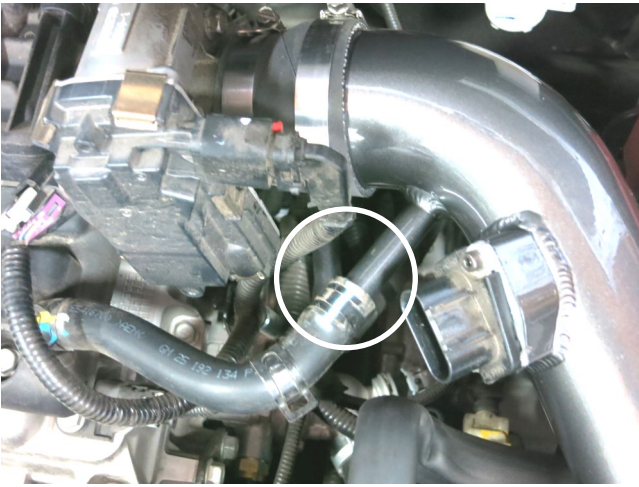

k. Slide the vent tube onto the AEM intake tube and secure with the spring clamp that was loosened in step 2b.

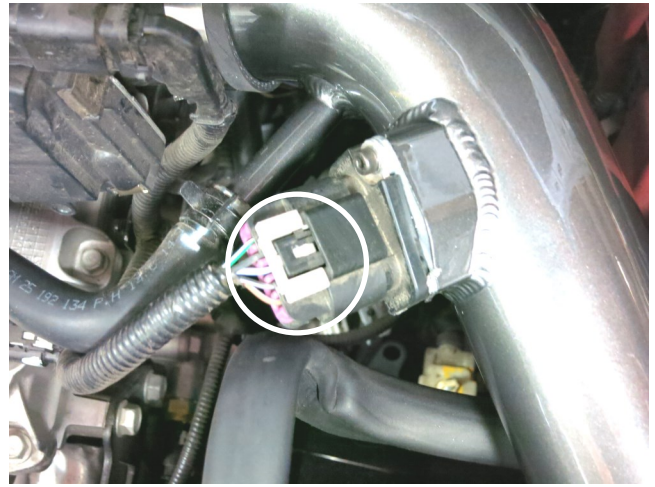

l. Connect the mass air sensor connector onto the sensor and slide the gray tab to lock it into place.



m. Align the AEM intake tube bracket with the stud mount and tighten with the provided washer and nut.

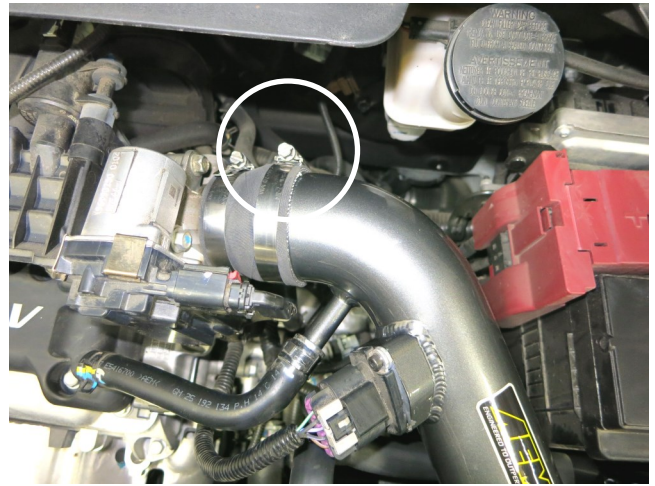

n. Tighten the other hose clamp at the throttle body at this time.



o. Install the AEM air filter onto the AEM intake tube and secure with the provided hose clamp.

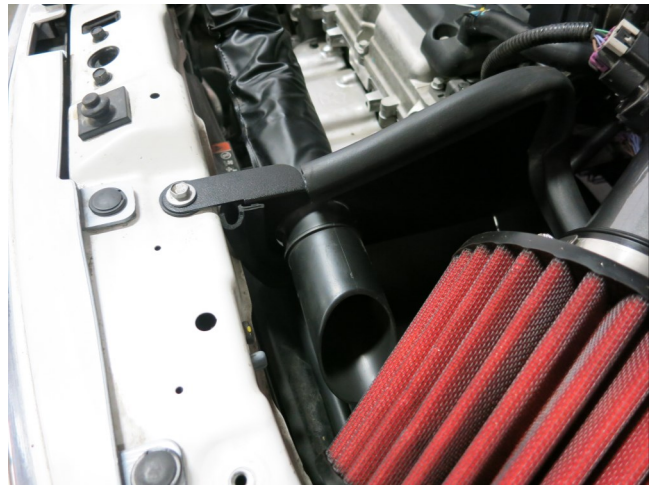

p. Install the fresh air scoop into the heat shield. Align the tabs, then spin to lock into place.



STOCK INTAKE INSTALLED



AEM INTAKE INSTALLED

4. Reassemble Vehicle

- a. Position the inlet pipes for the best fitment. Be sure that the pipes or any other components do not contact any part of the vehicle.
- b. Check for proper hood clearance. Re-adjust pipes if necessary and re-tighten them.
- c. Inspect the engine bay for any loose tools and check that all fasteners that were moved or removed are properly tightened.
- d. Reconnect negative battery terminal and start engine. Let the vehicle idle for 3 minutes. Perform a final inspection before driving the vehicle.

5. Service and Maintenance

- a. AEM Induction Systems requires cleaning the intake system's air filter element every 100,000 miles. When used in dusty or off-road environments, our filters will require cleaning more often. We recommend that you visually inspect your filter once every 25,000 miles to determine if the screen is still visible. When the screen is no longer visible some place on the filter element, it is time to clean it. To clean, purchase our Synthetic air filter cleaner, part number 1-1000 and follow the easy instructions.
- b. Use window cleaner to clean your powder coated AEM[®] intake tube.

NOTE: DO NOT USE aluminum polish on powder coated AEM[®] intake tubes.