



Equipped with AEM® *Dryflow™ Filter*
No Oil Required!

INSTALLATION INSTRUCTIONS

PART NUMBER: 21-728

2013

HYUNDAI GENESIS

L4-2.0L TURBO SEE *NOTE

ITEM NO.	PART NUMBER	DESCRIPTION	QTY.
A	9-0437	ADAPTER; SCOOP, HYUNDAI GENESIS 2.0T	1
B	2-1502	TUBE; HYUNDAI GENESIS 2.0L-2013	1
C	8-4014	EDGE TRIM, 14"	1
D	102466	EDGE TRIM; 1/16"GAP, 12"L	1
E	21-2047D	ELEMENT PARTS KIT 3.5" X 7" DRY MEDIA	1
F	9460	1/2" BNDHOSE CLAMP,3.31"-4.25"	1
G	9444	HOSE CLAMP, 2.31-3.25"	1
H	5-1036	COUPLER, GENESIS L4	1
I	9456	1/2" BNDHOSE CLAMP,3.15"-4.00"	1
J	8-4030	EDGE TRIM, 30"	1
K	2-620	MOUNTING BLOCK	1
L	2-647	SPACER, 1.00 OD X .250 ID X .6	1
M	1-1016	BOLT; HEX/FLANGE M6-1 X 30	2
N	8-4007	EDGE TRIM, 7"	3
O	20-8530-1	HEAT SHIELD; 21-728, MILD STL, TB/PC	1
P	1-127	ZIP TIE,8" TREE PUSH-MNT	1
Q	08160	WASHER; 1"D X 1/4 HOLE FENDER	1
R	8-101	VACUM CAP , 3/8	1
S	4093-3	HOSE CLAMP, 5/8	1

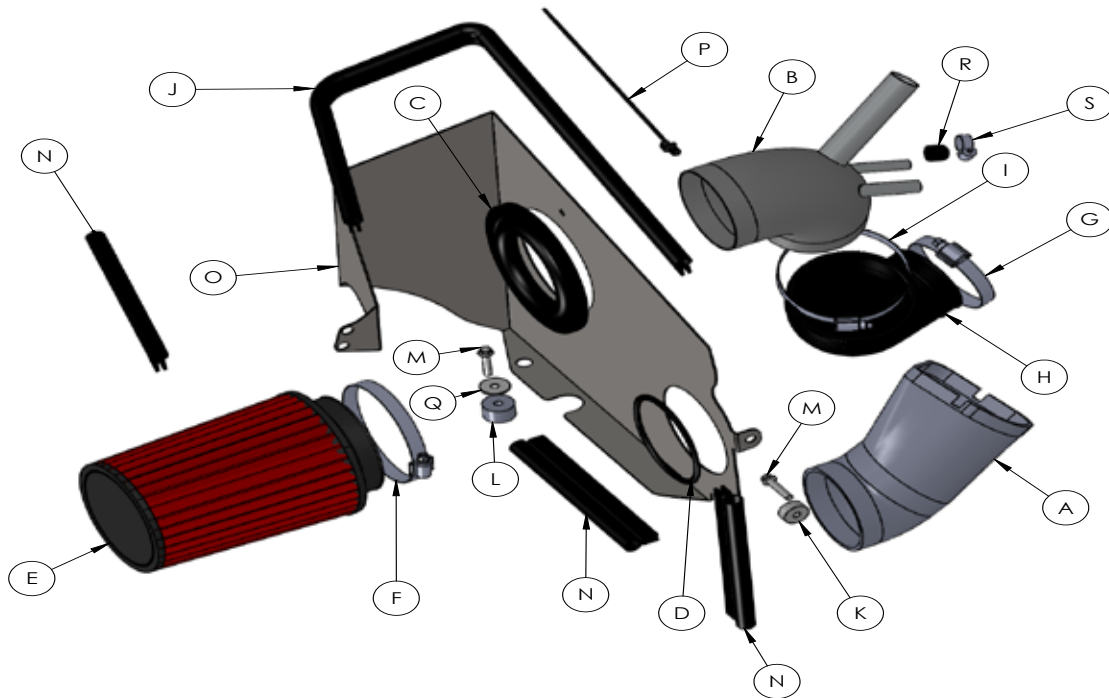

Read and understand these instructions BEFORE attempting to install this product. Failure to follow installation instructions and not using the provided hardware may damage the intake tube, throttle body and engine.

1. Preparing Vehicle

- a. Make sure vehicle is parked on a level surface.
- b. Set parking brake.
- c. If engine has run in the past two hours, let it cool down.
- d. Disconnect negative battery terminal.
- e. Do not discard stock components after removal of the factory system.

2. Removal of Stock System



a. Remove the recirculation hose on the OEM intake pipe.



b. Loosen the hose clamp on the intake pipe.



c. Loosen & remove the two M6 bolts securing the air box bracket that secures the air box bracket to the radiator core support.



d. Remove the M6 bolt holding the airbox in place.



e. Remove the four clips securing the scoop and set scoop aside for use with the AEM intake system.



f. Remove the factory air box.



g. Release the clips on the two PCV hoses (Manual Trans) and disconnect the hoses from the intake tube. (Automatic shown)



h. Loosen the hose clamp securing the stock tube onto the turbo inlet.



i. Remove the intake tube from the engine bay.



j. Remove the seal from the air box.

3. Installation of AEM® Intake System

- a. When installing the intake system, do not completely tighten the hose clamps or mounting hardware until instructed to do so.



- b. Install the OEM rubber gasket on the AEM scoop adapter (A)



- c. Remove the bolt on the fan shroud.



- d. Install the coupler (H) onto the Turbo inlet using the provided hose clamps (G) and (I).



- e. Set provided spacer (L) in place. Position the spacer in the indicated location.



f. Install the edge trim (J) & (N) on the outer edges of the heat shield as shown.



g. Install edge trim (C) and (D) on the two large holes as shown.



h. Place filter (E) and hose clamp (F) in the engine bay as shown.



i. For automatic cars use the provided cap (R) and hose clamp (S) to cap off the vent tube.



j. Place intake tube (B) through the hole in the heat shield (O) as shown.



k. Set heat shield (O) and intake tube (B) in place.



l. Install intake tube (B) into coupler (H) .

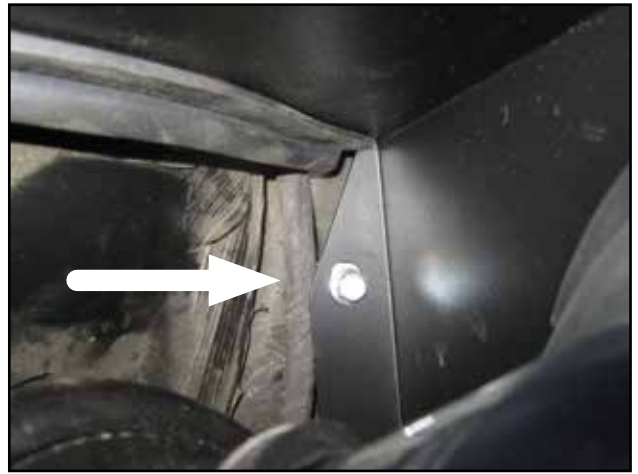

m. Install the M6 Bolt (M) and washer (Q) onto the bottom of the heat shield. Do not fully tighten at this time.



n. Install the mounting block (K) and M6 bolt (M) into the front mounting tab. Do not fully tighten at this time.



o. Now tighten the lower M6 (M) bolt. installed in step m.



p. Now tighten the front M6 bolt installed in step n.



q. Reinstall the OEM M6 bolts in the factory mounting bracket location.



r. Now tighten the two OEM M6 bolts.



s. Reconnect the PCV hoses and fasten with the OEM spring clamps.



t. Align the filter and tube then tighten hose clamps (F) and (I).



u. Install the AEM scoop adapter (A) into the OEM ducting.



v. Install the scoop and adapter as shown.



w. Reinstall the four clips used to secure the OEM air duct and re install the recirculation hose on AEM intake tube.

4. Reassemble Vehicle

- a. Position the inlet pipes for the best fitment. Be sure that the pipes or any other components do not contact any part of the vehicle. Tighten the rubber mount, all bolts, and hose clamps.
- b. Check for proper hood clearance. Re-adjust pipes if necessary and re-tighten them.
- c. Inspect the engine bay for any loose tools and check that all fasteners that were removed are properly tightened.
- d. Reconnect the negative battery terminal and start the engine. Let the vehicle idle for 3 minutes. Perform a final inspection before driving the vehicle.

5. Service and Maintenance

- a. AEM Induction Systems requires cleaning the intake system's air filter element every 100,000 miles. When used in dusty or off-road environments, our filters will require cleaning more often. We recommend that you visually inspect your filter once every 25,000 miles to determine if the screen is still visible. When the screen is no longer visible some place on the filter element, it is time to clean it. To clean, purchase our Synthetic air filter cleaner, part number 1-1000 and follow the easy instructions.
- b. Use window cleaner to clean your AEM® intake tube. **(NOTE: DO NOT USE aluminum polish on powder coated AEM intake tubes).**