



Equipped with AEM® *Dryflow™* Filter
No Oil Required!

INSTALLATION INSTRUCTIONS

PART NUMBER:21-640

2006-2008	MAZDA	MX-5	L4-2.0L	C.A.R.B. E.O. # D-670-6
2006-2009	MAZDA	MX-5 Miata	L4-2.0L	C.A.R.B. E.O. # D-670-6

PARTS LIST

Description	Qty.	Part Number
Element Parts Kit 3.00 X 5" Dry Ele.	1	21-203DK
Upper Pipe	1	2-704
Lower Pipe	1	2-705
Hose, Adapter 2.75/3.00 X 3" Bl.	1	5-273
Elbow, 2.75 X 85	1	5-278
Prefilter, 5" Black	1	1-4000
Mount, Rubber 5/8" X 6mm	2	1228598
Bolt, Socket 8-32 X 5/16 SS	2	1-2023
Washer, 6mm Soft Mount	4	08160
Nut, M6 Hex Serrated	4	444.460.04
1/2" Bnd. Hose Clamp, 2.56"-3.50"	1	9448
1/2" Bnd. Hose Clamp, 2.31-3.25"	1	9444
1/2" Bnd. Hose Clamp, 2.90"-3.75"	1	9452

Read and understand these instructions **BEFORE** attempting to install this product. Failure to follow installation instructions and not using the provided hardware may damage the intake tube, throttle body and engine.

1. Preparing Vehicle

- a. Make sure vehicle is parked on level surface.
- b. Set parking brake.
- c. If engine has run in the past two hours, let it cool down.
- d. Disconnect negative battery terminal.
- e. Raise the front of the vehicle with a jack. Refer to your owner's manual for proper jack and jack stand placement to properly support vehicle. Support your vehicle using properly rated jack stands before wheel removal or while working under the vehicle.

NEVER WORK UNDER A VEHICLE WITHOUT USING JACK STANDS.

- f. Do not discard stock components after removal of the factory system.

2. Removal of stock system

WARNING: Please follow these installation instructions carefully. The AEM® prefilter included with this kit must be installed on the AEM® air filter when used with a AEM® intake system. The AEM® intake system is a performance product that can be used safely during mild weather conditions. During harsh and inclement weather conditions, you must return your vehicle to stock OEM air box and intake tract configuration. Failure to follow these instructions will void your warranty.



a. Unclip the hard plastic breather hose from the breather nipple by squeezing the blue retaining clip.



b. Slide the purge solenoid valve (PSV) toward the back of the car to remove it from the steel mount on the inlet hose. Unclip the wire harness.



c. Unplug the MAF sensor from the wiring harness.

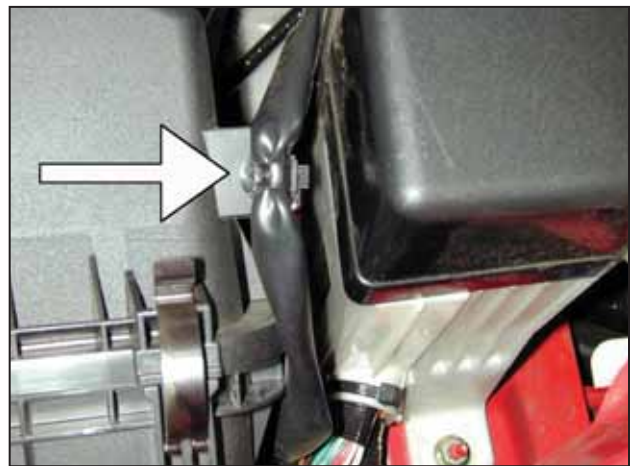

d. Unclip the MAF sensor wiring harness from the side of the air filter housing.



e. Unscrew the inlet tube from the throttle body and the air filter housing. Remove the inlet tube.



f. Remove the air filter housing lid by unhooking the metal retaining clips and sliding the lid out.



g. Remove the lower air filter housing and filter by removing the two nuts securing the housing to the chassis. Next, lift up on the back side of the housing and remove it from the vehicle.



h. Remove the retaining clips and bolts securing the driver side splash shield to the bumper and chassis. Remove the splash shield.



i. Remove the retaining clips and bolts securing the passenger side splash shield to the bumper and chassis. Remove the splash shield.



j. Remove the clips and bolts securing the center splash shield to the front bumper.



k. Remove the clips and bolts securing the driver side front fender liner and remove the liner. Disconnect the fog light and side marker light from the wiring harness.



l. Remove the clips and bolts securing the passenger side front fender liner and remove the liner. Disconnect the fog light and side marker light from the wiring harness.



m. In the grill on the bumper there are two removable plastic covers. Remove these to reveal two bolts securing the bumper to the bumper support. Remove the two bolts.



n. Remove the bolt securing the bumper to the driver side fender where the fender liner was removed.



o. Remove the bolt securing the bumper to the passenger side fender where the fender liner was removed.



p. Remove the bolts securing the bumper to the radiator support on the driver side.



q. Remove the bolts securing the bumper to the chassis on the passenger side. Carefully remove the front bumper and set aside in a safe place.

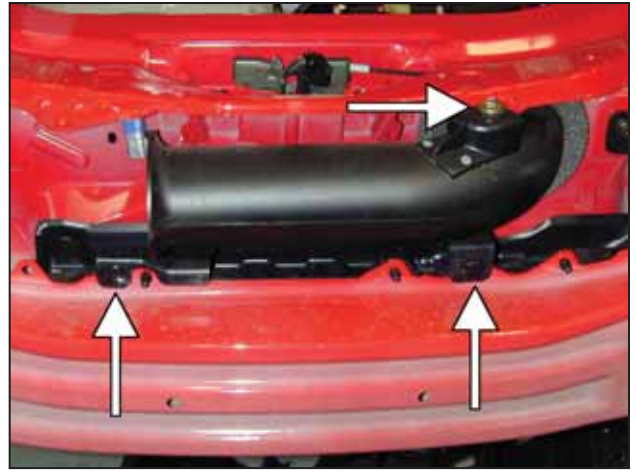

r. Remove the inlet air hose by removing the two retaining clips and the bolt securing it to the chassis.



s. Unhook the wiring harness from the horn attached to the bumper support. Remove the 4 driver side bolts securing the bumper support to the chassis. Remove the plastic clips securing the plastic splash shield between the bumper support and the chassis.



t. Remove the 4 remaining bolts securing the bumper support to the chassis on the passenger side. Remove the bumper support.



u. Remove the plastic splash shield from the bumper support.



v. Stock air box system removed.



w. Remove the stock MAF sensor from the air filter housing. Be careful not to damage the MAF sensor.

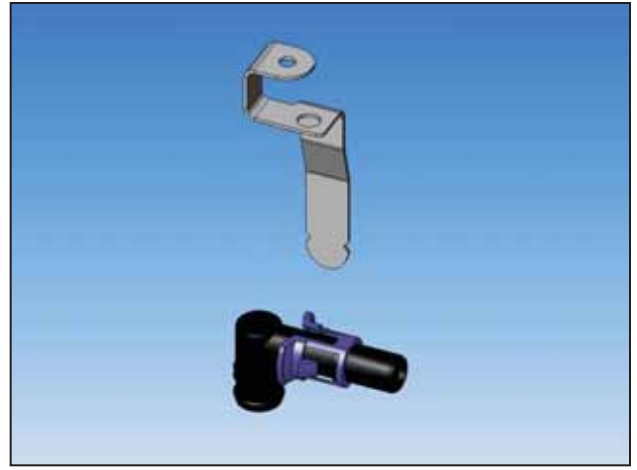

x. Remove the plastic breather nipple and the steel PSV bracket from the previously removed inlet tube.

3. Installation of AEM® intake system.

a. When installing the intake system, do not completely tighten the hose clamps or mounting hardware until instructed to do so.

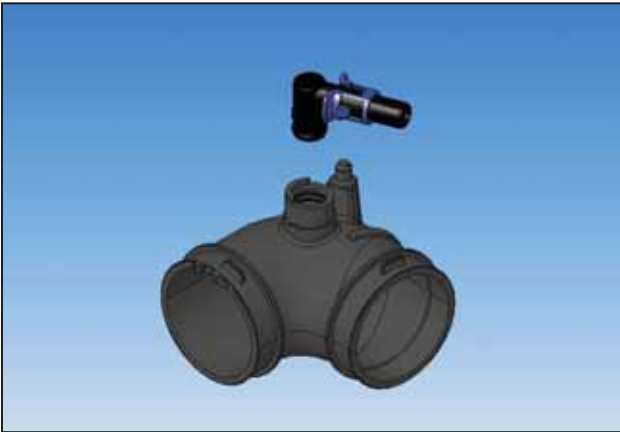

b. Install the plastic breather hose nipple from the stock inlet tube into the supplied EPDM coupler and secure using the stock spring clamp.

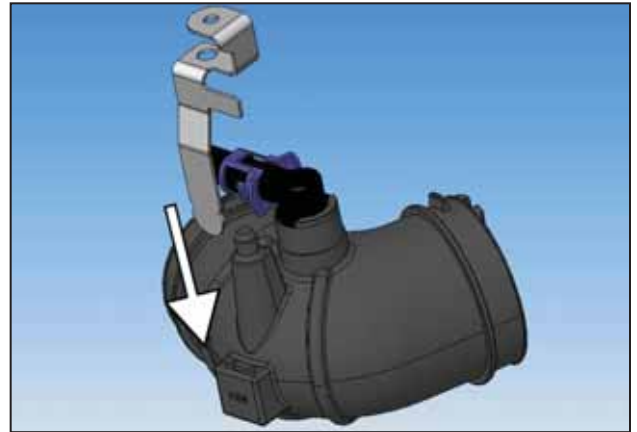

c. Install the steel PSV bracket from the stock inlet tube into the slot on the supplied EPDM coupler.



d. Remove the two stock hose clamps from the stock inlet tube and install them onto the EPDM coupler. Install the coupler onto the throttle body and secure.



e. Slide the PSV onto the bracket previously installed on the EPDM coupler. Plug the plastic breather hose onto the nipple. Be sure both are secure before proceeding.



f. Install the MAF sensor into the upper intake pipe (2-704) and secure using the two supplied 8-32 bolts. Install the reducing coupler onto the end of the intake pipe and secure using the supplied #9444 hose clamp as shown.



g. Ensure the inside of the AEM® intake pipe is free and clear of any debris. Install the upper intake pipe into the EPDM coupler on the throttle body. Secure using the stock hose clamp. Connect the MAF sensor connector to the MAF sensor.



h. Install the supplied 5/8" rubber mount in the location shown. Secure using the supplied flat washer and nylock nut.

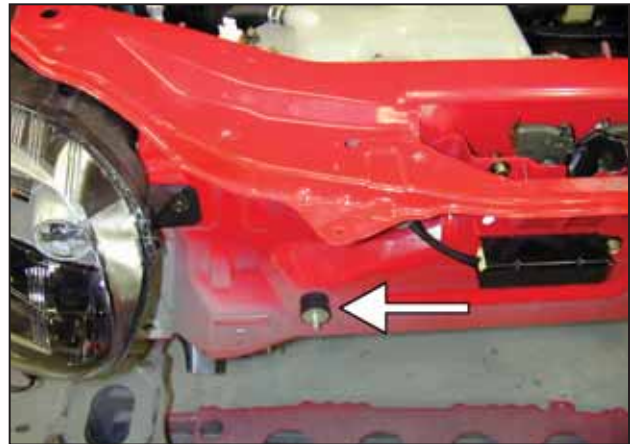

i. Install the other 5/8" rubber mount in the location shown. Secure using the supplied flat washer and nylock nut.



j. Ensure that the inside of the AEM® lower intake pipe is free and clear of any debris. Install the pipe into the reducing coupler on the upper intake pipe and align the pipe brackets with the rubber mounts. Once aligned, secure the pipe using a #9448 hose clamp.



k. Secure the intake pipe bracket to the rubber mount using a flat washer and a 6mm nut.



l. Secure the other pipe bracket using the remaining flat washer and nylock nut.



m. Install the AEM® air filter onto the end of the lower intake pipe. Push the air filter onto the inlet pipe until the stop in the filter is reached. Secure the air filter onto the inlet pipe with a hose clamp.



n. Install the front bumper support using the 8 previously removed bolts. Ensure the air filter does not contact any part of the vehicle.



o. Position the AEM® intake for best fitment. Tighten the nuts on the mounting brackets. Re-adjust the pipe if necessary. Install the supplied filter sock to protect it from excess dust and water.
NOTE: Please be aware the prefilter is water repellent, not water proof. Depending on conditions and usage the water repellent treatment is good for 1 to 2 years. See the parts list to reorder a new prefilter if necessary.

4. Reassemble Vehicle

- Reinstall the bumper, splash shields and fender liners. Reconnect the fog light and the side marker wiring harness connectors. Check for proper intake fitment and readjust if needed.
- Position the inlet pipes for the best fitment. Be sure that the pipes or any other components do not contact any part of the vehicle. Tighten the rubber mount, all bolts, and hose clamps.
- Check for proper hood clearance. Re-adjust pipes if necessary and re-tighten them.
- Inspect the engine bay for any loose tools and check that all fasteners that were moved or removed are properly tightened.
- Reconnect the negative battery terminal and start the engine. Let the vehicle idle for 3 minutes. Perform a final inspection before driving the vehicle.

5. CARB Sticker Placement

- The C.A.R.B. exemption sticker, (attached), must be visible under the hood so that an emissions inspector can see it when the vehicle is required to be tested for emissions. California requires testing every two years, other state may vary.

6. Service and Maintenance

- a. AEM Induction Systems requires cleaning the intake system's air filter element every 100,000 miles. When used in dusty or off-road environments, our filters will require cleaning more often. We recommend that you visually inspect your filter once every 25,000 miles to determine if the screen is still visible. When the screen is no longer visible some place on the filter element, it is time to clean it. To clean, purchase our Synthetic air filter cleaner, part number 99-0624 and follow the easy instructions.
- b. Use window cleaner to clean your powder coated AEM® intake tube.

NOTE: DO NOT USE aluminum polish on powder coated AEM® intake tubes.