



Equipped with AEM® Dryflow™ Filter
No Oil Required!

INSTALLATION INSTRUCTIONS

PART NUMBER:

21-472B (Blue Finish)

21-472C (Gun Metal Grey Finish)

21-472P (Vacuum Metalized Chrome-VMC)

21-472R (Red Finish)

2003-2004	SUBARU	Impreza	H4-2.5L	C.A.R.B E.O. # D-670-15
2002	SUBARU	Impreza RS	H4-2.5L	C.A.R.B E.O. # D-670-15

PARTS LIST

Description	Qty.	Part Number
Element Parts Kit 3.00 X 5" Dry Ele.	1	21-203DK
Upper Pipe	1	2-565
Lower Pipe	1	2-566
Hose, Adapter 2.75/3.00 X 3" Bl.	1	5-273
Hose, Hump 3.00/3.00x3.0" Blk.	1	5-530
Hose; 1/2"ID X 25"L	2	5-5025
Hose; 1/2"ID X 15"L	1	5-5015
Mount, Rubber 5/8" X 6mm	1	1228598
Grommet, 7/16"	1	784632
Rubber Edge Trim 12"	1	102466
Connector, Plastic 1/2" Blk.	1	8-117
Washer, 3/8 X 1 Flat Zinc	1	1-3026
Washer, 6mm Soft Mount	2	08160
Nut, M6 Hex Serrated	2	444.460.04
1/2" Bnd. Hose Clamp, 2.31-3.25"	1	9444
1/2" Bnd. Hose Clamp, 2.56"-3.50"	3	9448
Hose Clamp, 1"	6	08407

Read and understand these instructions **BEFORE** attempting to install this product. Failure to follow installation instructions and not using the provided hardware may damage the intake tube, throttle body and engine.

The AEM® intake system is a performance product that can be used safely during mild weather conditions. During harsh and inclement weather conditions, you must return your vehicle to stock OEM air box and intake tract configuration. Failure to follow these instructions will void your warranty.

1. Preparing Vehicle

- a. Make sure vehicle is parked on level surface.
- b. Set parking brake.
- c. If engine has run in the past two hours, let it cool down.
- d. Disconnect negative battery terminal.
- e. Do not discard stock components after removal of the factory system.

2. Removal of stock system



a. Factory air box system installed.



b. Loosen and remove bolt.



c. Loosen and remove bolt. This bolt will be used with the installation of the AEM® intake system.



d. Loosen and remove nut.

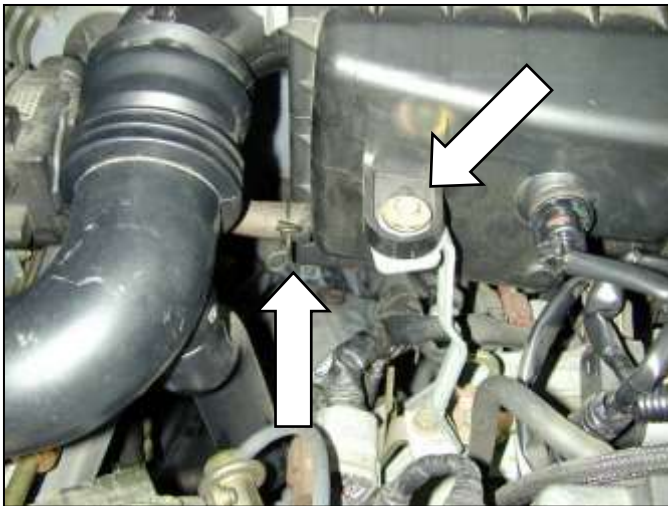

e. Disconnect crankcase breather hose from the air box. Loosen and remove bolt.



f. Loosen and remove the bolt on the driver's side.



g. Remove the Inlet Air Temperature Sensor (IAT) from the air box. Be careful not to damage this sensor. Vehicles not equipped with IAT proceed to step h.



h. Remove the breather hose from the air box and manifold.



i. Loosen the hose clamp at the throttle body.



j. Gently pull the resonator from the fender. Remove the resonator and air box assembly.

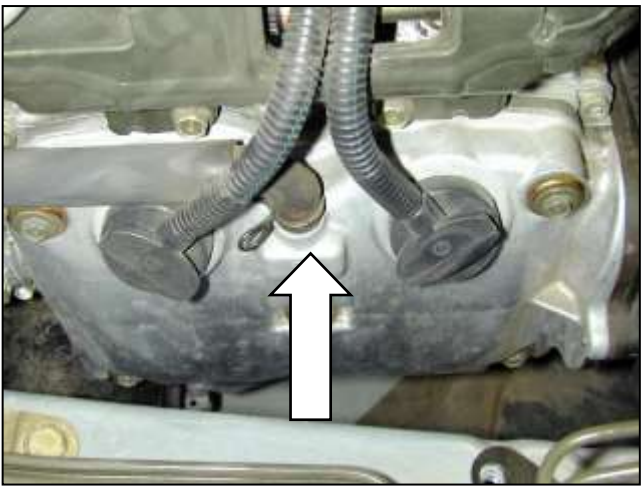

k. Remove the crankcase breather from valve cover located on the passenger side.



l. Remove the crankcase breather hose located on the driver's side.

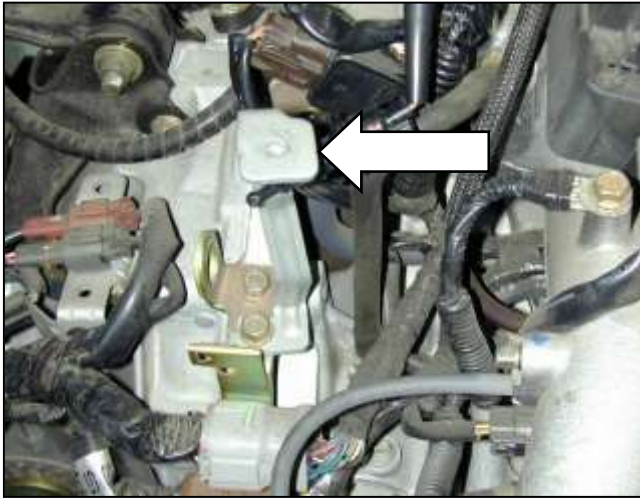

m. Loosen and remove the air box bracket bolt. Remove the air box bracket.

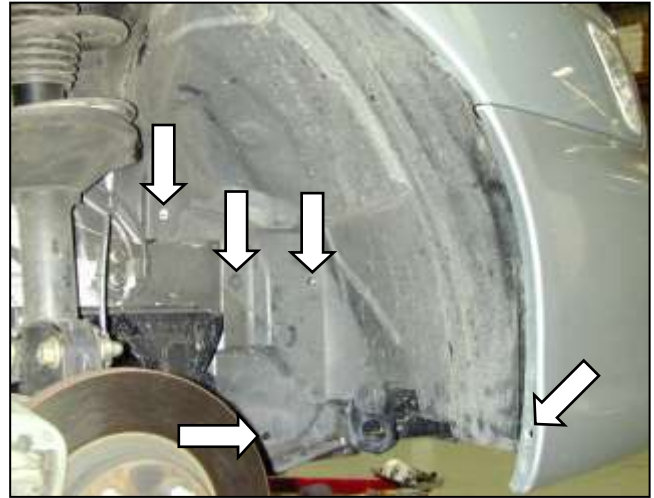

n. Raise the front of the vehicle with a jack. Refer to your owner's manual for proper jack and jack stand placement to properly support vehicle. Support your vehicle using properly rated jack stands before wheel removal or while working under the vehicle.
NEVER WORK UNDER A VEHICLE WITHOUT USING JACK STANDS.
Remove the passenger front wheel. Remove the plastic tabs for the splash shield. Retain for installation.



o. Remove the two clips from the underside splash shield. Peel back the splash shield.

3. Installation of AEM® intake system.

a. When installing the intake system, do not completely tighten the hose clamps or mounting hardware until instructed to do so.



b. Attach the reducer coupler to the throttle body and secure with the provided hose clamp. Loosely attach the second hose clamp to the open end of the coupler.



c. Remove the stock rubber mount by loosening and removing the nut underneath the bracket. This mount will be replaced with a new one provided in the kit.



d. Insert the new rubber mount into the bracket. Secure with washer and nylok nut.



e. Insert the upper intake pipe. Line up the bracket to the newly installed rubber mount.



f. Once you line up the bracket to the rubber mount, secure with washer and nylok nut. Refer to the diagram below.

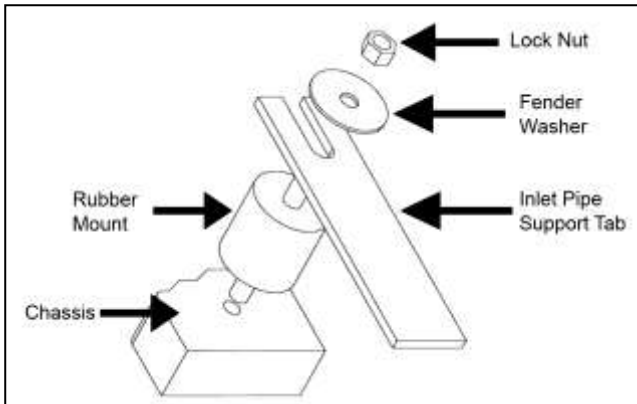

Proper installation of rubber mount assembly.



i. Insert the IAT into the upper intake pipe.
NOTE: Vehicles not equipped with IAT, proceed to step 3j.



g. Attach the rubber edge trim. Cut away any excess.



h. Insert the rubber grommet. This is for the IAT.



j. Insert 1/2" connector into upper intake pipe.



k. Attach breather hose and provided hose clamps.



l. Attach the breather hose to the passenger side valve cover and secure with provided hose clamp.



m. Attach the other end of the breather hose to the upper intake pipe and secure with provided hose clamp.



n. Attach the breather hose to the driver's side valve cover and secure with the provided hose clamp.



o. Attach the other end of the breather hose to the upper intake pipe and secure with provided hose clamp.



p. In order to attach the lower intake pipe, you must remove the nut for the ABS unit located in the fender well. Refer to *step 3q*. for location.



q. Attach the lower intake pipe bracket to the ABS unit's stud that is located in the passenger fender well. Secure with provided washer and original nut.



r. Once the lower intake pipe is in place, secure both pipes with the hump hose. Fasten with the provided hose clamps.



s. Attach the air filter element and secure. Ensure the air filter has proper clearance.



AEM[®] intake system installed

4. Reassemble Vehicle

a. **Fender liner and splash shield:** Install the fender liner, splash shield and hardware that were removed earlier in steps 2n and 2o.

NOTE: Failure to install the fender liner will result in diminished performance and increase the potential for engine damage due to water ingestion in rainy conditions.

b. **Wheel:** Install the passenger front wheel using the factory torque specification (see owner's manual).

c. Position the inlet pipes for the best fitment. Be sure that the pipes or any other components do not contact any part of the vehicle. Tighten the rubber mount, all bolts, and hose clamps.

d. Check for proper hood clearance. Re-adjust pipes if necessary and re-tighten them.

e. Inspect the engine bay for any loose tools and check that all fasteners that were moved or removed are properly tightened.

f. Reconnect negative battery terminals and start engine. Let the vehicle idle for 3 minutes. Perform a final inspection before driving the vehicle.

5. CARB Sticker Placement

a. The C.A.R.B. exemption sticker, (attached), must be visible under the hood so that an emissions inspector can see it when the vehicle is required to be tested for emissions. California requires testing every two years, other states may vary.

6. Service and Maintenance

a. It is recommended that you service your AEM[®] Dryflow™ filter every 20,000 miles for optimum performance. Use AEM Dryflow cleaning kit part # 21-110.

b. Use aluminum polish to clean your polished AEM[®] intake tube.

c. Use window cleaner to clean your powder coated AEM[®] intake tube. **(NOTE: DO NOT USE aluminum polish on powder coated AEM intake tubes).**